

Appendix F

7th Street Existing Traffic Counts

Intersection ID: 1805125
Count Date: 11/29/2018

N 7TH ST & E MCDOWELL RD

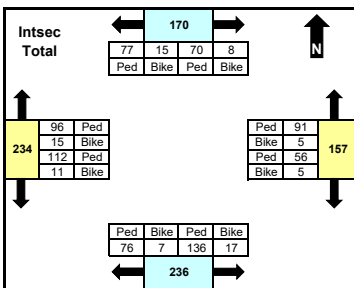
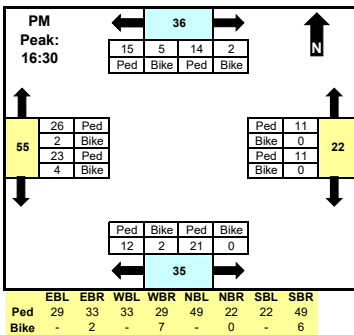
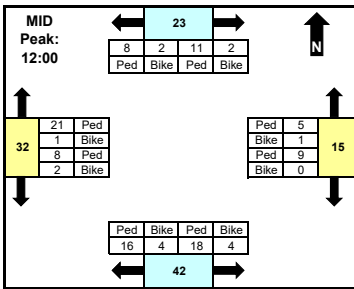
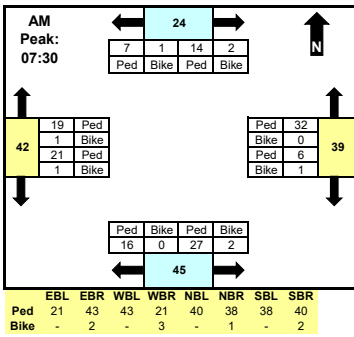

	North		East		South		West		Total
	CW	CCW	CW	CCW	CW	CCW	CW	CCW	
AM	16	8	7	32	16	29	20	22	150
MID	13	10	9	6	20	22	22	10	112
PM	16	20	11	11	14	21	28	27	148
Total	78	92	61	96	83	153	111	123	797

CW = Clockwise
CCW = Counter-clockwise

Comments
Unless shown otherwise, MID period defined as 10:00 AM - 2:00 PM. Crosswalk peaks defined based on total intersection volume for all vehicle types.

Time	North Leg		East Leg		South Leg		West Leg		INTSEC	TOTAL								
	CW	CCW	CW	CCW	CW	CCW	CW	CCW										
0:00										0								
0:15										0								
0:30										0								
0:45										0								
1:00										0								
1:15										0								
1:30										0								
1:45										0								
2:00										0								
2:15										0								
2:30										0								
2:45										0								
3:00										0								
3:15										0								
3:30										0								
3:45										0								
4:00										0								
4:15										0								
4:30										0								
4:45										0								
5:00										0								
5:15										0								
5:30										0								
5:45										0								
6:00										0								
6:15										0								
6:30	2	0	2	0	0	0	1	0	2	0	20							
6:45	3	0	3	0	1	0	3	0	1	0	2	0	17					
7:00	1	0	7	0	2	0	5	0	1	0	3	0	7	0	26			
7:15	3	0	5	0	0	0	3	0	0	0	3	1	1	0	11	1	28	
7:30	0	0	1	0	0	0	4	0	4	0	4	0	4	0	2	0	19	
7:45	5	0	4	1	3	0	9	0	6	0	9	1	1	0	12	0	51	
8:00	4	1	1	0	1	1	8	0	5	0	0	7	0	2	0	30	0	
8:15	5	1	1	0	2	0	11	0	1	0	14	1	7	1	5	1	50	
8:30																	0	0
8:45																	0	0
9:00																	0	0
9:15																	0	0
9:30																	0	0
9:45																	0	0
10:00																	0	0
10:15																	0	0
10:30																	0	0
10:45																	0	0
11:00	2	1	1	0	4	0	1	0	4	1	8	0	2	2	3	0	29	0
11:15	3	0	7	0	3	0	9	0	3	0	4	2	1	1	4	1	38	0
11:30	7	0	10	2	7	2	7	0	8	0	13	0	3	3	8	0	70	0
11:45	3	1	3	0	2	1	3	1	6	0	4	2	3	1	3	2	35	0
12:00	2	0	5	0	3	0	3	1	9	1	2	1	8	0	2	0	37	0
12:15	2	0	2	1	3	0	2	0	3	2	6	0	7	1	3	1	33	0
12:30	6	1	1	0	2	0	0	0	2	1	5	3	3	0	2	1	27	0
12:45	1	1	0	1	1	0	0	0	2	0	5	0	3	0	1	0	15	0
13:00																	0	0
13:15																	0	0
13:30																	0	0
13:45																	0	0
14:00																	0	0
14:15																	0	0
14:30																	0	0
14:45																	0	0
15:00																	0	0
15:15																	0	0
15:30																	0	0
15:45	0	0	6	0	3	0	4	0	1	0	10	0	8	0	1	0	33	0
16:00	3	0	2	0	3	0	1	1	5	0	4	5	2	3	7	0	36	0
16:15	8	0	6	1	5	0	2	0	2	0	2	0	7	0	4	0	37	0
16:30	5	0	4	2	2	0	4	0	2	1	6	0	8	0	4	0	38	0
16:45	1	2	2	0	2	0	5	0	3	0	4	0	4	1	10	2	36	0
17:00	0	0	3	2	2	0	0	0	5	1	9	0	7	1	5	2	37	0
17:15	4	0	1	3	3	1	4	2	0	0	7	1	3	0	6	0	35	0
17:30	4	0	0	2	2	0	2	0	1	0	8	0	2	1	2	0	20	0
17:45																	0	0
18:00																	0	0
18:15																	0	0
18:30																	0	0
18:45																	0	0
19:00																	0	0
19:15																	0	0
19:30																	0	0
19:45																	0	0
20:00																	0	0
20:15																	0	0
20:30																	0	0
20:45																	0	0
21:00																	0	0
21:15																	0	0
21:30																	0	0
21:45																	0	0
22:00																	0	0
22:15																	0	0
22:30																	0	0
22:45																	0	0
23:00																	0	0
23:15																	0	0
23:30																	0	0
23:45																	0	0
Total	70	8	77	15	56	5	91	5	76	7	136	17	96	15	112	11	797	
AM Peak Hr:																		7:30
PK Vol	14	2	7	1	6	1	32	0	16	0	27	2	19	1	21	1	150	
MID Peak Hr:																		12:00
PK Vol	11	2	8															

Intersection ID: 1805125
Count Date: 11/29/2018

N 7TH ST & E MCDOWELL RD

From North (SB) From East (WB) From South (NB) From West (EB)
N 7TH ST E MCDOWELL RD N 7TH ST E MCDOWELL RD INTSEC

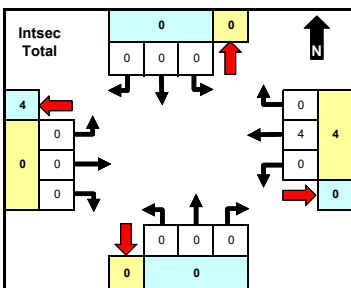
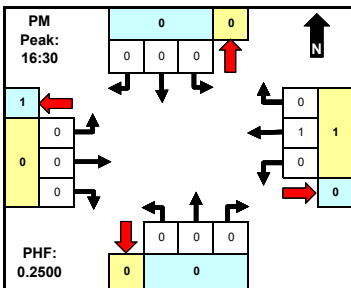
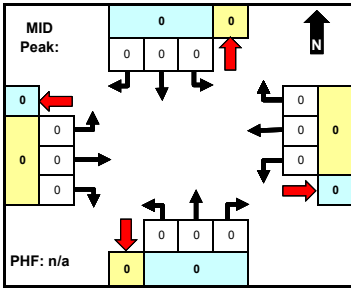
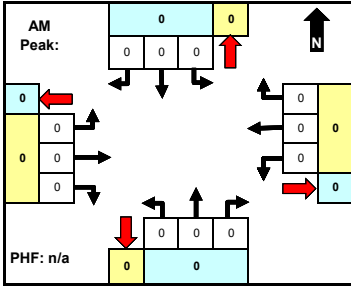

	North		East		South		West		Total
	App	Dep	App	Dep	App	Dep	App	Dep	
AM	0	0	0	0	0	0	0	0	0
MID	0	0	0	0	0	0	0	0	0
PM	0	0	1	0	0	0	0	1	1
Total	0	0	1	0	0	0	0	1	1

Comments

Unless shown otherwise, MID period defined as 10:00 AM - 2:00 PM. Peaks defined based on total intersection volume for all vehicle types.

Time	LT	Thru	RT	U	LT	Thru	RT	U	LT	Thru	RT	U	LT	Thru	RT	U	TOTAL
0:00																	0
0:15																	0
0:30																	0
0:45																	0
1:00																	0
1:15																	0
1:30																	0
1:45																	0
2:00																	0
2:15																	0
2:30																	0
2:45																	0
3:00																	0
3:15																	0
3:30																	0
3:45																	0
4:00																	0
4:15																	0
4:30																	0
4:45																	0
5:00																	0
5:15																	0
5:30																	0
5:45																	0
6:00																	0
6:15																	0
6:30	0	0	0	0	0	0	0	0	0	0	0	0	0	0	0	0	0
6:45	0	0	0	0	0	0	1	0	0	0	0	0	0	0	0	0	1
7:00	0	0	0	0	0	0	0	0	0	0	0	0	0	0	0	0	0
7:15	0	0	0	0	0	0	0	0	0	0	0	0	0	0	0	0	0
7:30	0	0	0	0	0	0	0	0	0	0	0	0	0	0	0	0	0
7:45	0	0	0	0	0	0	0	0	0	0	0	0	0	0	0	0	0
8:00	0	0	0	0	0	0	0	0	0	0	0	0	0	0	0	0	0
8:15	0	0	0	0	0	0	0	0	0	0	0	0	0	0	0	0	0
8:30																	0
8:45																	0
9:00																	0
9:15																	0
9:30																	0
9:45																	0
10:00																	0
10:15																	0
10:30																	0
10:45																	0
11:00	0	0	0	0	0	0	0	0	0	0	0	0	0	0	0	0	0
11:15	0	0	0	0	0	0	0	0	0	0	0	0	0	0	0	0	0
11:30	0	0	0	0	0	0	0	0	0	0	0	0	0	0	0	0	0
11:45	0	0	0	0	0	0	0	0	0	0	0	0	0	0	0	0	0
12:00	0	0	0	0	0	0	0	0	0	0	0	0	0	0	0	0	0
12:15	0	0	0	0	0	0	0	0	0	0	0	0	0	0	0	0	0
12:30	0	0	0	0	0	0	0	0	0	0	0	0	0	0	0	0	0
12:45	0	0	0	0	0	0	0	0	0	0	0	0	0	0	0	0	0
13:00																	0
13:15																	0
13:30																	0
13:45																	0
14:00																	0
14:15																	0
14:30																	0
14:45																	0
15:00																	0
15:15																	0
15:30																	0
15:45																	0
16:00	0	0	0	0	0	0	0	0	0	0	0	0	0	0	0	0	0
16:15	0	0	0	0	0	0	0	0	0	0	0	0	0	0	0	0	0
16:30	0	0	0	0	0	0	0	0	0	0	0	0	0	0	0	0	0
16:45	0	0	0	0	0	0	0	0	0	0	0	0	0	0	0	0	0
17:00	0	0	0	0	0	0	0	0	0	0	0	0	0	0	0	0	0
17:15	0	0	0	0	0	0	1	0	0	0	0	0	0	0	0	0	1
17:30	0	0	0	0	0	0	0	0	0	0	0	0	0	0	0	0	0
17:45	0	0	0	0	0	0	2	0	0	0	0	0	0	0	0	0	2
18:00																	0
18:15																	0
18:30																	0
18:45																	0
19:00																	0
19:15																	0
19:30																	0
19:45																	0
20:00																	0
20:15																	0
20:30																	0
20:45																	0
21:00																	0
21:15																	0
21:30																	0
21:45																	0
22:00																	0
22:15																	0
22:30																	0
22:45																	0
23:00																	0
23:15																	0
23:30																	0
23:45																	0
Total	0	0	0	0	0	0	4	0	0	0	0	0	0	0	0	0	4
AM Peak Hr:																	7:30
Pk Vol	0	0	0	0	0	0	0	0	0	0	0	0	0	0	0	0	0
PHF	n/a	n/a	n/a	n/a	n/a	n/a	n/a	n/a	n/a	n/a	n/a	n/a	n/a	n/a	n/a	n/a	n/a
MID Peak Hr:																	12:00
Pk Vol	0	0	0	0	0	0	0	0	0	0	0	0	0	0	0	0	0
PHF	n/a	n/a	n/a	n/a	n/a	n/a	n/a	n/a	n/a	n/a	n/a	n/a	n/a	n/a	n/a	n/a	n/a
PM Peak Hr:																	16:30
Pk Vol	0	0	0	0	0	1	0	0	0	0	0	0	0	0	0	0	1
PHF	n/a	n/a	n/a	n/a	n/a	0.250	n/a	n/a	n/a	n/a	n/a	n/a	n/a	n/a	n/a	n/a	0.250

Intersection ID: 1805126
Count Date: 11/29/2018

N 7TH ST & E PALM LN

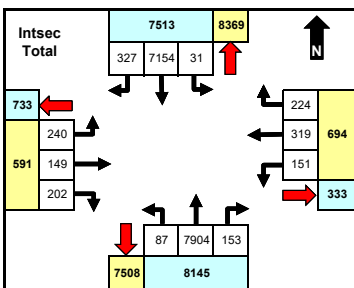
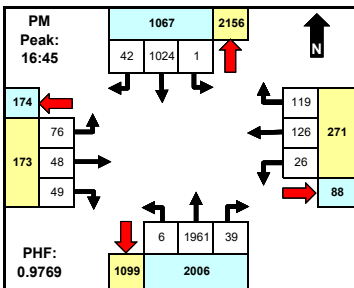
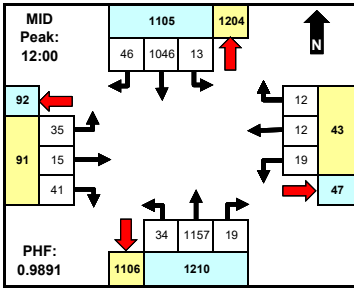
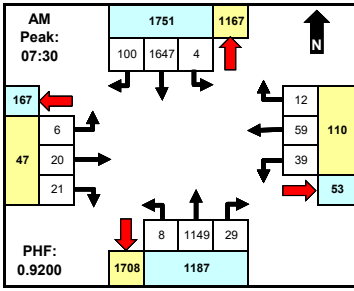

	North		East		South		West		Total
	App	Dep	App	Dep	App	Dep	App	Dep	
AM	1751	1167	110	53	1187	1708	47	167	3095
MID	1105	1204	43	47	1210	1106	91	92	2449
PM	1067	2156	271	88	2006	1099	173	174	3517
Total	7513	8369	694	333	8145	7508	591	733	16943

Comments

Unless shown otherwise, MID period defined as 10:00 AM - 2:00 PM. Peaks defined based on total intersection volume for all vehicle types.

Time	From North (SB)		From East (WB)		From South (NB)		From West (EB)		INTSEC	TOTAL								
	N 7TH ST		E PALM LN		N 7TH ST		E PALM LN											
	LT	Thru	RT	U	LT	Thru	RT	U										
0:00										0								
0:15										0								
0:30										0								
0:45										0								
1:00										0								
1:15										0								
1:30										0								
1:45										0								
2:00										0								
2:15										0								
2:30										0								
2:45										0								
3:00										0								
3:15										0								
3:30										0								
3:45										0								
4:00										0								
4:15										0								
4:30										0								
4:45										0								
5:00										0								
5:15										0								
5:30										0								
5:45										0								
6:00										0								
6:15										0								
6:30	1	280	4	0	5	2	1	0	1	122	3	0	1	1	0	0	421	
6:45	0	368	4	0	4	4	4	0	1	158	1	0	1	1	1	3	0	549
7:00	1	371	18	0	6	4	1	0	1	186	3	0	4	4	0	0	0	599
7:15	0	425	20	0	5	7	2	0	1	266	4	0	2	6	3	0	0	741
7:30	1	423	24	0	9	14	5	0	1	253	7	0	2	6	0	0	0	745
7:45	1	413	23	0	10	10	0	0	3	362	7	1	3	5	3	0	0	841
8:00	1	391	23	0	12	19	3	0	2	254	6	0	0	4	9	0	0	724
8:15	1	420	30	0	8	16	4	0	2	280	9	0	1	5	9	0	0	785
8:30																		0
8:45																		0
9:00																		0
9:15																		0
9:30																		0
9:45																		0
10:00																		0
10:15																		0
10:30																		0
10:45																		0
11:00	1	240	9	0	4	1	0	0	8	260	5	0	11	0	7	0	0	546
11:15	1	232	10	0	4	2	3	0	6	274	4	0	13	3	14	0	0	566
11:30	1	236	10	0	8	4	1	0	7	260	7	0	9	4	8	0	0	554
11:45	2	247	11	0	3	4	8	0	8	281	6	0	9	3	5	0	0	583
12:00	4	255	9	0	4	2	5	0	5	302	3	0	12	3	15	0	0	619
12:15	2	234	12	0	7	3	2	0	15	309	5	0	8	6	6	0	0	609
12:30	1	278	8	0	5	3	2	0	7	282	7	0	10	3	12	0	0	618
12:45	6	279	17	0	3	4	3	0	7	264	4	0	5	3	8	0	0	603
13:00																		0
13:15																		0
13:30																		0
13:45																		0
14:00																		0
14:15																		0
14:30																		0
14:45																		0
15:00																		0
15:15																		0
15:30																		0
15:45																		0
16:00	4	261	15	0	9	14	12	0	2	422	9	0	18	6	15	0	0	787
16:15	0	270	22	0	8	28	12	0	1	460	7	0	24	16	13	0	0	861
16:30	0	254	12	0	6	27	12	0	2	477	7	0	13	16	16	0	0	842
16:45	1	252	12	0	5	32	34	0	2	452	10	0	25	12	19	0	0	856
17:00	0	253	9	0	3	35	28	0	0	516	12	0	18	6	12	0	0	892
17:15	0	267	12	0	11	30	23	0	0	510	3	0	19	15	10	0	0	900
17:30	0	252	9	0	7	29	34	0	4	483	14	0	14	15	8	0	0	869
17:45	2	253	4	1	5	25	25	0	1	471	10	0	18	6	7	0	0	828
18:00																		0
18:15																		0
18:30																		0
18:45																		0
19:00																		0
19:15																		0
19:30																		0
19:45																		0
20:00																		0
20:15																		0
20:30																		0
20:45																		0
21:00																		0
21:15																		0
21:30																		0
21:45																		0
22:00																		0
22:15																		0
22:30																		0
22:45																		0
23:00																		0
23:15																		0
23:30																		0
23:45																		0
Total	31	7154	327	1	151	319	224	0	87	7904	153	1	240	149	202	0	0	16943
AM Peak Hr:																		7:30
PK Vol	4	1647	100	0	39	59	12	0	8	1149	29	1	6	20	21	0	0	3095
PHF	1.000	0.973	0.833	n/a	0.813	0.776	0.600	n/a	0.667	0.794	0.806	0.250	0.500	0.833	0.583	n/a	0	0.920
MID Peak Hr:																		12:00
PK Vol	13	1046	46	0	19	12	12	0	34	1157	19	0	35	15	41	0	0	2449
PHF	0.542	0.937	0.676	n/a	0.679	0.750	0.600	n/a	0.567	0.936	0.679	n/a	0.729	0.625	0.683	n/a	0	0.989
PM Peak Hr:																		16:45
PK Vol	1	1024	42	0	26	126	119	0	6	1961	39	0	76	48	49	0	0	3517
PHF	0.250	0.959	0.875	n/a	0.591	0.900	0.875	n/a	0.375	0.950	0.696	n/a	0.760	0.800	0.645	n/a	0	0.977



Intersection ID: 1805126
Count Date: 11/29/2018

N 7TH ST & E PALM LN

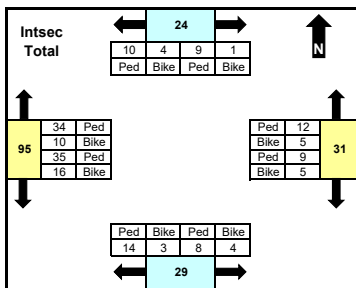
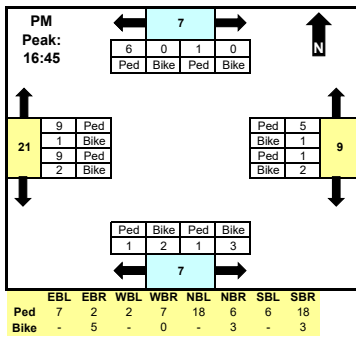
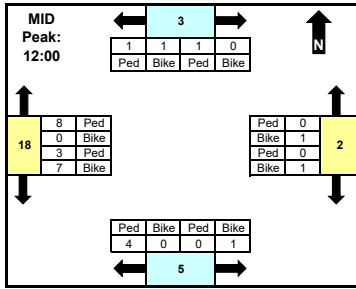
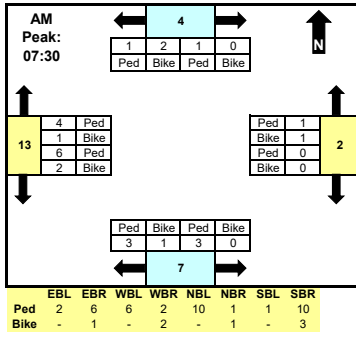

	North		East		South		West		Total
	CW	CCW	CW	CCW	CW	CCW	CW	CCW	
AM	1	3	0	2	4	3	5	8	26
MID	1	2	1	1	4	1	8	10	28
PM	1	6	3	6	3	4	10	11	44
Total	10	14	14	17	17	12	44	51	179

CW = Clockwise
CCW = Counter-clockwise

Comments
Unless shown otherwise, MID period defined as 10:00 AM - 2:00 PM. Crosswalk peaks defined based on total intersection volume for all vehicle types.

Time	North Leg		East Leg		South Leg		West Leg		INTSEC	TOTAL							
	CW	CCW	CW	CCW	CW	CCW	CW	CCW									
0:00										0							
0:15										0							
0:30										0							
0:45										0							
1:00										0							
1:15										0							
1:30										0							
1:45										0							
2:00										0							
2:15										0							
2:30										0							
2:45										0							
3:00										0							
3:15										0							
3:30										0							
3:45										0							
4:00										0							
4:15										0							
4:30										0							
4:45										0							
5:00										0							
5:15										0							
5:30										0							
5:45										0							
6:00										0							
6:15										0							
6:30	0	0	0	0	2	0	0	0	2	0	7						
6:45	0	0	0	0	0	0	0	0	0	1	0						
7:00	0	0	0	1	2	0	0	0	0	1	0						
7:15	0	0	0	0	0	0	0	0	0	0	1						
7:30	1	0	0	0	0	0	1	0	2	0	3						
7:45	0	0	1	0	0	0	0	1	0	0	1						
8:00	0	0	0	1	0	0	0	0	0	0	1						
8:15	0	0	0	0	0	0	1	0	1	0	2						
8:30											0						
8:45											0						
9:00											0						
9:15											0						
9:30											0						
9:45											0						
10:00											0						
10:15											0						
10:30											0						
10:45											0						
11:00	0	0	0	0	0	0	0	0	0	0	0						
11:15	0	0	0	0	1	0	0	0	2	0	3						
11:30	0	0	0	0	1	0	0	0	0	3	0						
11:45	0	0	0	0	1	0	2	1	1	0	1						
12:00	0	0	0	0	0	0	1	0	0	0	2						
12:15	0	0	0	0	1	0	0	1	0	0	2						
12:30	1	0	1	0	0	0	0	3	0	0	5						
12:45	0	0	1	0	0	0	0	0	0	0	1						
13:00											0						
13:15											0						
13:30											0						
13:45											0						
14:00											0						
14:15											0						
14:30											0						
14:45											0						
15:00											0						
15:15											0						
15:30											0						
15:45	0	0	0	0	2	0	0	0	0	6	3						
16:00	0	0	0	0	0	0	0	0	0	6	3						
16:15	0	0	0	0	0	0	1	1	0	0	2						
16:30	2	1	1	0	0	0	0	0	1	0	5						
16:45	0	0	2	0	0	0	2	0	1	2	7						
17:00	0	0	4	0	0	0	3	0	0	0	7						
17:15	0	0	0	1	1	0	1	0	0	2	5						
17:30	1	0	0	0	1	0	0	0	1	0	3						
17:45	4	0	1	0	0	1	0	0	1	0	7						
18:00											0						
18:15											0						
18:30											0						
18:45											0						
19:00											0						
19:15											0						
19:30											0						
19:45											0						
20:00											0						
20:15											0						
20:30											0						
20:45											0						
21:00											0						
21:15											0						
21:30											0						
21:45											0						
22:00											0						
22:15											0						
22:30											0						
22:45											0						
23:00											0						
23:15											0						
23:30											0						
23:45											0						
Total	9	1	10	4	9	5	12	5	14	3	8	4	34	10	35	16	179
AM Peak Hr:																	7:30
PK Vol	1	0	1	2	0	0	1	1	3	1	3	0	4	1	6	2	26
MID Peak Hr:																	12:00
PK Vol	1	0	1	1	0	1	0	1	4	0	0	1	8	0	3	7	28
PM Peak Hr:																	16:45
PK Vol	1	0	6	0	1	2	5	1	1	2	1	3	9	1	9	2	44

Intersection ID: 1805126
Count Date: 11/29/2018

N 7TH ST & E PALM LN

From North (SB) From East (WB) From South (NB) From West (EB) INTSEC
N 7TH ST E PALM LN N 7TH ST E PALM LN

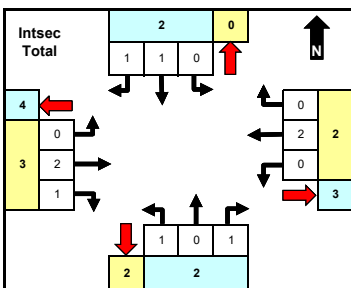
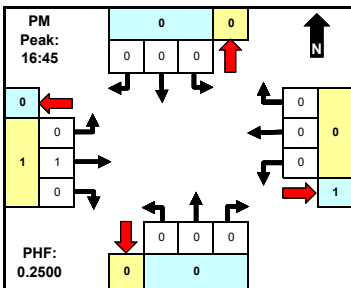
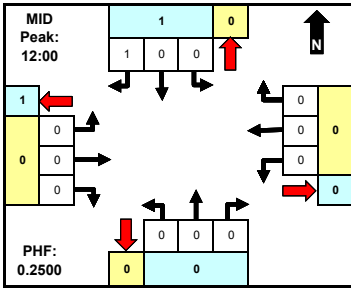
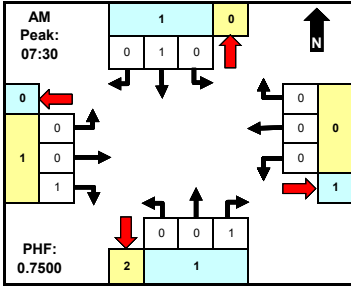

	North		East		South		West		Total
	App	Dep	App	Dep	App	Dep	App	Dep	
AM	1	0	0	1	1	2	1	0	3
MID	1	0	0	0	0	0	0	1	1
PM	0	0	0	1	0	0	1	0	1
Total	2	0	2	3	2	2	3	4	9

Comments

Unless shown otherwise, MID period defined as 10:00 AM - 2:00 PM. Peaks defined based on total intersection volume for all vehicle types.

Time	From North (SB)				From East (WB)				From South (NB)				From West (EB)				TOTAL
	LT	Thru	RT	U	LT	Thru	RT	U	LT	Thru	RT	U	LT	Thru	RT	U	
0:00																	0
0:15																	0
0:30																	0
0:45																	0
1:00																	0
1:15																	0
1:30																	0
1:45																	0
2:00																	0
2:15																	0
2:30																	0
2:45																	0
3:00																	0
3:15																	0
3:30																	0
3:45																	0
4:00																	0
4:15																	0
4:30																	0
4:45																	0
5:00																	0
5:15																	0
5:30																	0
5:45																	0
6:00																	0
6:15																	0
6:30	0	0	0	0	0	0	0	0	0	0	0	0	0	0	0	0	0
6:45	0	0	0	0	0	0	0	0	0	0	0	0	0	0	0	0	0
7:00	0	0	0	0	0	0	0	0	0	0	0	0	0	0	0	0	0
7:15	0	0	0	0	0	0	0	0	0	0	0	0	0	0	0	0	0
7:30	0	0	0	0	0	0	0	0	0	0	0	0	0	0	0	0	0
7:45	0	0	0	0	0	0	0	0	0	0	0	0	0	0	0	0	0
8:00	0	0	0	0	0	0	0	0	0	0	0	0	0	0	0	0	0
8:15	0	0	0	0	0	0	0	0	0	0	0	0	0	0	0	0	0
8:30	0	1	0	0	0	0	0	0	0	0	0	0	0	0	0	0	0
8:45																	0
9:00																	0
9:15																	0
9:30																	0
9:45																	0
10:00																	0
10:15																	0
10:30																	0
10:45																	0
11:00	0	0	0	0	0	0	0	0	0	0	0	0	0	0	0	0	0
11:15	0	0	0	0	0	0	0	0	0	0	0	0	0	0	0	0	0
11:30	0	0	0	0	0	0	0	0	0	0	0	0	0	0	0	0	0
11:45	0	0	0	0	0	0	0	0	0	0	0	0	0	0	0	0	0
12:00	0	0	0	1	0	0	0	0	0	0	0	0	0	0	0	0	0
12:15	0	0	0	0	0	0	0	0	0	0	0	0	0	0	0	0	0
12:30	0	0	0	0	0	0	0	0	0	0	0	0	0	0	0	0	0
12:45	0	0	0	0	0	0	0	0	0	0	0	0	0	0	0	0	0
13:00																	0
13:15																	0
13:30																	0
13:45																	0
14:00																	0
14:15																	0
14:30																	0
14:45																	0
15:00																	0
15:15																	0
15:30																	0
15:45																	0
16:00	0	0	0	0	0	0	0	0	0	0	0	0	0	0	0	0	0
16:15	0	0	0	0	0	0	0	0	1	0	0	0	0	0	0	0	0
16:30	0	0	0	0	0	0	0	0	0	0	0	0	0	0	0	0	0
16:45	0	0	0	0	0	0	0	0	0	0	0	0	0	0	0	0	0
17:00	0	0	0	0	0	0	0	0	0	0	0	0	0	0	0	0	0
17:15	0	0	0	0	0	0	0	0	0	0	0	0	0	0	0	0	0
17:30	0	0	0	0	0	0	0	0	0	0	0	0	0	0	0	0	0
17:45	0	0	0	0	0	0	0	0	0	0	0	0	0	0	0	0	0
18:00																	0
18:15																	0
18:30																	0
18:45																	0
19:00																	0
19:15																	0
19:30																	0
19:45																	0
20:00																	0
20:15																	0
20:30																	0
20:45																	0
21:00																	0
21:15																	0
21:30																	0
21:45																	0
22:00																	0
22:15																	0
22:30																	0
22:45																	0
23:00																	0
23:15																	0
23:30																	0
23:45																	0
Total	0	1	1	0	0	0	2	0	0	1	0	0	0	2	1	0	9
AM Peak Hr:																	7:30
Pk Vol	0	1	0	0	0	0	0	0	0	0	0	0	0	1	0	0	3
PHF	n/a	0.250	n/a	n/a	n/a	n/a	n/a	n/a	n/a	n/a	0.250	n/a	n/a	n/a	0.250	n/a	0.750
MID Peak Hr:																	12:00
Pk Vol	0	0	1	0	0	0	0	0	0	0	0	0	0	0	0	0	1
PHF	n/a	n/a	0.250	n/a	n/a	n/a	n/a	n/a	n/a	n/a	n/a	n/a	n/a	n/a	n/a	n/a	0.250
PM Peak Hr:																	16:45
Pk Vol	0	0	0	0	0	0	0	0	0	0	0	0	0	1	0	0	1
PHF	n/a	n/a	n/a	n/a	n/a	n/a	n/a	n/a	n/a	n/a	n/a	n/a	n/a	0.250	n/a	n/a	0.250

Intersection ID: 1805127
Count Date: 11/29/2018

N 7TH ST & E VIRGINIA AVE

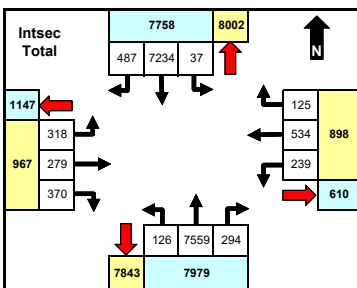
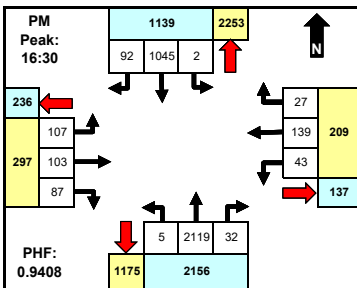
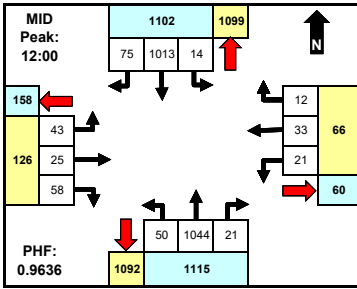
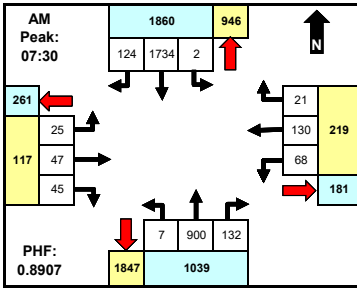

	North		East		South		West		Total
	App	Dep	App	Dep	App	Dep	App	Dep	
AM	1860	946	219	181	1039	1847	117	261	3238
MID	1102	1099	66	60	1115	1092	126	158	2409
PM	1139	2253	209	137	2156	1175	297	236	3801
Total	7758	8002	898	610	7979	7843	967	1147	17602

Comments

Unless shown otherwise, MID period defined as 10:00 AM - 2:00 PM. Peaks defined based on total intersection volume for all vehicle types.

Time	From North (SB)		From East (WB)		From South (NB)		From West (EB)		INTSEC	TOTAL								
	N 7TH ST		E VIRGINIA AVE		N 7TH ST		E VIRGINIA AVE											
	LT	Thru	RT	U	LT	Thru	RT	U										
0:00										0								
0:15										0								
0:30										0								
0:45										0								
1:00										0								
1:15										0								
1:30										0								
1:45										0								
2:00										0								
2:15										0								
2:30										0								
2:45										0								
3:00										0								
3:15										0								
3:30										0								
3:45										0								
4:00										0								
4:15										0								
4:30										0								
4:45										0								
5:00										0								
5:15										0								
5:30										0								
5:45										0								
6:00										0								
6:15										0								
6:30	0	302	12	0	3	10	4	0	1	117	8	0	1	4	3	0	465	
6:45	0	366	18	0	4	15	4	0	0	125	9	0	4	2	6	0	553	
6:55	0	405	12	0	17	17	2	0	4	168	15	0	5	3	7	0	655	
7:00	0	428	18	0	17	22	4	0	0	203	16	0	5	4	13	0	730	
7:15	0	449	35	0	20	38	4	0	0	198	41	0	6	11	14	0	816	
7:30	1	452	26	0	25	36	11	0	4	273	51	0	5	13	11	0	908	
7:45	1	395	36	0	14	33	3	0	1	211	27	0	7	16	10	0	754	
8:00	0	438	27	0	9	23	3	0	2	218	13	0	7	7	10	0	757	
8:15																	0	0
8:30																	0	0
8:45																	0	0
9:00																	0	0
9:15																	0	0
9:30																	0	0
9:45																	0	0
10:00																	0	0
10:15																	0	0
10:30																	0	0
10:45																	0	0
11:00	2	234	17	0	1	7	4	0	10	239	5	0	9	11	16	0	555	
11:15	5	222	14	0	2	3	5	0	20	248	10	0	11	2	20	0	562	
11:30	4	207	16	0	10	5	3	0	8	230	7	0	19	5	13	0	527	
11:45	7	235	16	0	6	5	4	0	8	269	3	0	12	6	18	0	589	
12:00	2	241	17	0	2	5	3	0	16	258	4	0	12	8	14	0	582	
12:15	4	244	17	0	4	6	4	0	13	277	4	0	7	4	13	0	597	
12:30	3	260	19	0	6	9	3	0	10	261	4	0	11	7	12	0	605	
12:45	5	268	22	0	9	13	2	0	11	248	9	0	13	6	19	0	625	
13:00																	0	0
13:15																	0	0
13:30																	0	0
13:45																	0	0
14:00																	0	0
14:15																	0	0
14:30																	0	0
14:45																	0	0
15:00																	0	0
15:15																	0	0
15:30																	0	0
15:45																	0	0
16:00	0	286	17	0	11	32	9	0	5	423	11	0	28	16	27	0	865	
16:15	1	244	21	0	6	38	6	0	3	495	9	0	19	14	21	0	877	
16:30	0	266	19	0	18	38	8	0	2	481	9	0	27	27	21	0	916	
16:45	0	263	30	0	3	23	6	0	1	536	7	0	19	15	16	0	919	
17:00	1	266	27	0	16	36	9	0	1	558	6	0	33	29	28	0	1010	
17:15	1	250	16	0	6	42	4	0	1	544	10	0	28	32	22	0	956	
17:30	0	258	19	0	13	47	11	0	1	477	7	0	15	19	20	0	887	
17:45	0	255	16	0	17	31	9	0	4	502	9	0	15	18	16	0	892	
18:00																	0	0
18:15																	0	0
18:30																	0	0
18:45																	0	0
19:00																	0	0
19:15																	0	0
19:30																	0	0
19:45																	0	0
20:00																	0	0
20:15																	0	0
20:30																	0	0
20:45																	0	0
21:00																	0	0
21:15																	0	0
21:30																	0	0
21:45																	0	0
22:00																	0	0
22:15																	0	0
22:30																	0	0
22:45																	0	0
23:00																	0	0
23:15																	0	0
23:30																	0	0
23:45																	0	0
Total	37	7234	487	0	239	534	125	0	126	7559	294	0	318	279	370	0	17602	
AM Peak Hr:																		7:30
Pk Vol	2	1734	124	0	68	130	21	0	7	900	132	0	25	47	45	0	3235	
PHF	0.500	0.959	0.861	n/a	0.680	0.855	0.477	n/a	0.438	0.824	0.647	n/a	0.893	0.734	0.804	n/a	0.891	
MID Peak Hr:																		12:00
Pk Vol	14	1013	75	0	21	33	12	0	50	1044	21	0	43	25	58	0	2409	
PHF	0.700	0.945	0.852	n/a	0.583	0.635	0.750	n/a	0.781	0.942	0.583	n/a	0.827	0.781	0.763	n/a	0.964	
PM Peak Hr:																		16:30
Pk Vol	2	1045	92	0	43	139	27	0	5	2119	32	0	107	103	87	0	3801	
PHF	0.500	0.982	0.767	n/a	0.597	0.827	0.750	n/a	0.625	0.949	0.800	n/a	0.811	0.805	0.777	n/a	0.941	

Intersection ID: 1805127
Count Date: 11/29/2018

N 7TH ST & E VIRGINIA AVE

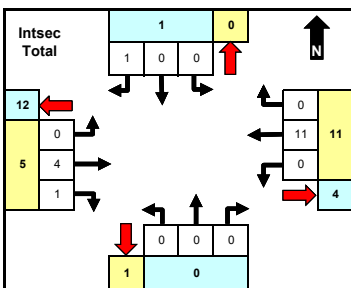
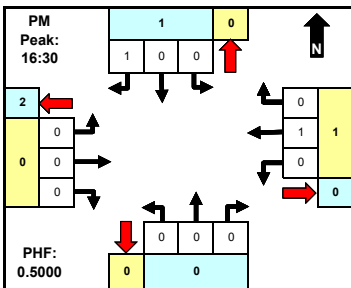
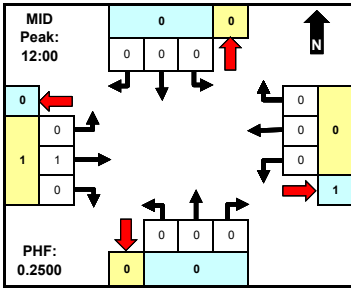
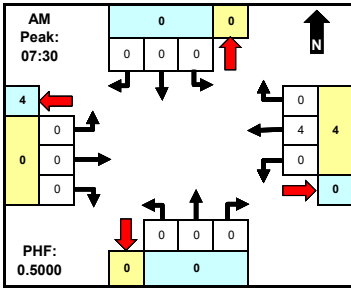

	North		East		South		West		Total
	App	Dep	App	Dep	App	Dep	App	Dep	
AM	0	0	4	0	0	0	0	0	4
MID	0	0	0	1	0	0	1	0	1
PM	1	0	1	0	0	0	0	2	2
Total	1	0	11	4	0	1	5	12	17

Comments
Unless shown otherwise, MID period defined as 10:00 AM - 2:00 PM. Peaks defined based on total intersection volume for all vehicle types.

Time	From North (SB)				From East (WB)				From South (NB)				From West (EB)				INTSEC	TOTAL
	N 7TH ST		E VIRGINIA AVE		N 7TH ST		E VIRGINIA AVE		N 7TH ST		E VIRGINIA AVE		N 7TH ST		E VIRGINIA AVE			
	LT	Thru	RT	U	LT	Thru	RT	U	LT	Thru	RT	U	LT	Thru	RT	U		
0:00																	0	
0:15																	0	
0:30																	0	
0:45																	0	
1:00																	0	
1:15																	0	
1:30																	0	
1:45																	0	
2:00																	0	
2:15																	0	
2:30																	0	
2:45																	0	
3:00																	0	
3:15																	0	
3:30																	0	
3:45																	0	
4:00																	0	
4:15																	0	
4:30																	0	
4:45																	0	
5:00																	0	
5:15																	0	
5:30																	0	
5:45																	0	
6:00																	0	
6:15																	0	
6:30	0	0	0	0	0	0	0	0	0	0	0	0	0	0	1	0	1	
6:45	0	0	0	0	0	0	0	0	0	0	0	0	0	0	0	0	0	
7:00	0	0	0	0	0	0	2	0	0	0	0	0	0	0	0	0	2	
7:15	0	0	0	0	0	0	2	0	0	0	0	0	0	0	0	0	2	
7:30	0	0	0	0	0	0	0	0	0	0	0	0	0	0	0	0	0	
7:45	0	0	0	0	0	0	2	0	0	0	0	0	0	0	0	0	2	
8:00	0	0	0	0	0	0	1	0	0	0	0	0	0	0	0	0	1	
8:15	0	0	0	0	0	0	1	0	0	0	0	0	0	0	0	0	1	
8:30																	0	
8:45																	0	
9:00																	0	
9:15																	0	
9:30																	0	
9:45																	0	
10:00																	0	
10:15																	0	
10:30																	0	
10:45																	0	
11:00	0	0	0	0	0	0	0	0	0	0	0	0	0	0	0	0	0	
11:15	0	0	0	0	0	0	0	0	0	0	0	0	0	0	0	0	0	
11:30	0	0	0	0	0	0	0	0	0	0	0	0	0	0	0	0	0	
11:45	0	0	0	0	0	0	0	0	0	0	0	0	0	0	0	0	0	
12:00	0	0	0	0	0	0	0	0	0	0	0	0	0	0	0	0	0	
12:15	0	0	0	0	0	0	0	0	0	0	0	0	0	0	0	0	0	
12:30	0	0	0	0	0	0	0	0	0	0	0	0	0	0	0	0	0	
12:45	0	0	0	0	0	0	0	0	0	0	0	0	1	0	0	0	1	
13:00																	0	
13:15																	0	
13:30																	0	
13:45																	0	
14:00																	0	
14:15																	0	
14:30																	0	
14:45																	0	
15:00																	0	
15:15																	0	
15:30																	0	
15:45																	0	
16:00	0	0	0	0	0	0	1	0	0	0	0	0	0	0	1	1	3	
16:15	0	0	0	0	0	0	1	0	0	0	0	0	0	0	0	0	1	
16:30	0	0	0	1	0	0	0	0	0	0	0	0	0	0	0	0	1	
16:45	0	0	0	0	0	0	0	0	0	0	0	0	0	0	0	0	0	
17:00	0	0	0	0	0	0	1	0	0	0	0	0	0	0	0	0	1	
17:15	0	0	0	0	0	0	0	0	0	0	0	0	0	0	0	0	0	
17:30	0	0	0	0	0	0	0	0	0	0	0	0	1	0	0	0	1	
17:45	0	0	0	0	0	0	0	0	0	0	0	0	0	0	0	0	0	
18:00																	0	
18:15																	0	
18:30																	0	
18:45																	0	
19:00																	0	
19:15																	0	
19:30																	0	
19:45																	0	
20:00																	0	
20:15																	0	
20:30																	0	
20:45																	0	
21:00																	0	
21:15																	0	
21:30																	0	
21:45																	0	
22:00																	0	
22:15																	0	
22:30																	0	
22:45																	0	
23:00																	0	
23:15																	0	
23:30																	0	
23:45																	0	
Total	0	0	1	0	0	11	0	0	0	0	0	0	4	1	0	0	17	
AM Peak Hr:																	7:30	
Pk Vol	0	0	0	0	0	4	0	0	0	0	0	0	0	0	0	0	4	
PHF	n/a	n/a	n/a	n/a	n/a	0.500	n/a	n/a	n/a	n/a	n/a	n/a	n/a	n/a	n/a	n/a	0.500	
MID Peak Hr:																	12:00	
Pk Vol	0	0	0	0	0	0	0	0	0	0	0	0	1	0	0	0	1	
PHF	n/a	n/a	n/a	n/a	n/a	n/a	n/a	n/a	n/a	n/a	n/a	n/a	0.250	n/a	n/a	n/a	0.250	
PM Peak Hr:																	16:30	
Pk Vol	0	0	1	0	0	1	0	0	0	0	0	0	0	0	0	0	2	
PHF	n/a	n/a	0.250	n/a	n/a	0.250	n/a	n/a	n/a	n/a	n/a	n/a	n/a	n/a	n/a	n/a	0.500	



Intersection ID: 1805127
Count Date: 11/29/2018

N 7TH ST & E VIRGINIA AVE

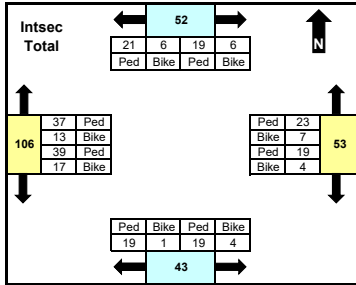
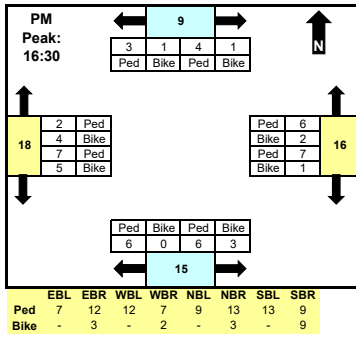
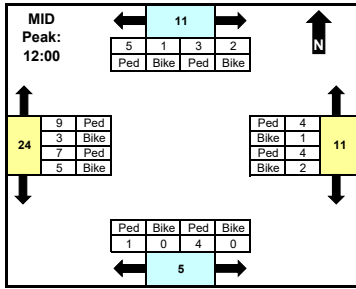
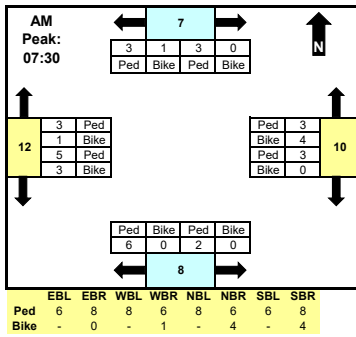

	North		East		South		West		Total
	CW	CCW	CW	CCW	CW	CCW	CW	CCW	
AM	3	4	3	7	6	2	4	8	37
MID	5	6	6	5	1	4	12	12	51
PM	5	4	8	8	6	9	6	12	58
Total	25	27	23	30	20	23	50	56	254

CW = Clockwise
CCW = Counter-clockwise

Comments
Unless shown otherwise, MID period defined as 10:00 AM - 2:00 PM. Crosswalk peaks defined based on total intersection volume for all vehicle types.

Time	North Leg		East Leg		South Leg		West Leg		INTSEC	TOTAL							
	CW	CCW	CW	CCW	CW	CCW	CW	CCW									
0:00										0							
0:15										0							
0:30										0							
0:45										0							
1:00										0							
1:15										0							
1:30										0							
1:45										0							
2:00										0							
2:15										0							
2:30										0							
2:45										0							
3:00										0							
3:15										0							
3:30										0							
3:45										0							
4:00										0							
4:15										0							
4:30										0							
4:45										0							
5:00										0							
5:15										0							
5:30										0							
5:45										0							
6:00										0							
6:15										0							
6:30	0	0	2	0	0	0	2	0	1	0	6						
6:45	1	0	0	0	1	0	0	0	0	0	2						
7:00	0	0	0	0	0	0	0	0	0	0	1						
7:15	0	0	0	0	1	0	1	0	0	2	6						
7:30	0	0	1	0	1	0	1	1	0	1	7						
7:45	1	0	0	0	0	1	1	3	0	2	12						
8:00	1	0	1	0	0	0	0	1	0	0	6						
8:15	1	0	1	0	2	0	1	2	0	0	12						
8:30											0						
8:45											0						
9:00											0						
9:15											0						
9:30											0						
9:45											0						
10:00											0						
10:15											0						
10:30											0						
10:45											0						
11:00	0	0	0	1	0	0	1	0	0	0	5						
11:15	1	0	0	0	0	0	0	0	1	0	15						
11:30	3	0	4	0	0	1	0	0	0	2	14						
11:45	0	0	1	0	0	0	2	0	0	1	10						
12:00	1	1	2	1	1	0	0	1	0	2	17						
12:15	1	0	0	0	2	1	0	0	0	2	8						
12:30	1	1	3	0	3	0	3	1	0	4	20						
12:45	0	0	0	0	0	0	0	0	1	0	6						
13:00											0						
13:15											0						
13:30											0						
13:45											0						
14:00											0						
14:15											0						
14:30											0						
14:45											0						
15:00											0						
15:15											0						
15:30											0						
15:45	1	1	0	1	1	0	1	0	4	0	15						
16:00											0						
16:15	1	0	1	0	1	0	2	0	1	0	11						
16:30	2	0	1	0	2	0	4	0	2	0	21						
16:45	2	1	2	0	4	0	1	0	4	0	23						
17:00	0	0	0	1	0	0	0	0	1	0	4						
17:15	0	0	0	0	1	1	1	2	0	0	10						
17:30	1	0	0	0	1	0	1	0	0	1	11						
17:45	1	2	2	1	0	0	0	0	1	0	12						
18:00											0						
18:15											0						
18:30											0						
18:45											0						
19:00											0						
19:15											0						
19:30											0						
19:45											0						
20:00											0						
20:15											0						
20:30											0						
20:45											0						
21:00											0						
21:15											0						
21:30											0						
21:45											0						
22:00											0						
22:15											0						
22:30											0						
22:45											0						
23:00											0						
23:15											0						
23:30											0						
23:45											0						
Total	19	6	21	6	19	4	23	7	19	1	19	4	37	13	39	17	254
AM Peak Hr:																	7:30
PK Vol	3	0	3	1	3	0	3	4	6	0	2	0	3	1	5	3	37
MID Peak Hr:																	12:00
PK Vol	3	2	5	1	4	2	4	1	1	0	4	0	9	3	7	5	51
PM Peak Hr:																	16:30
PK Vol	4	1	3	1	7	1	6	2	6	0	6	3	2	4	7	5	58

Intersection ID: 1805128
Count Date: 11/29/2018

N 7TH ST & E THOMAS RD

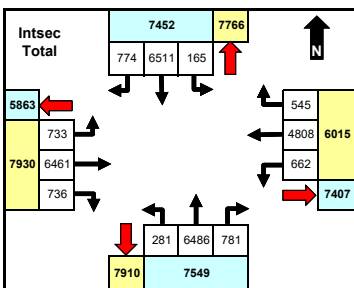
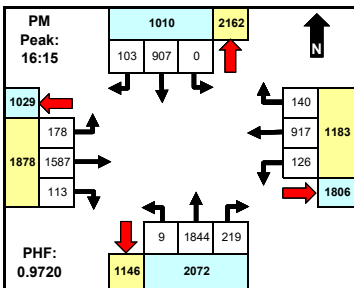
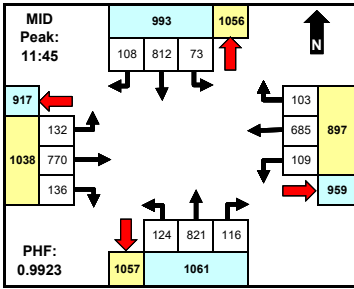
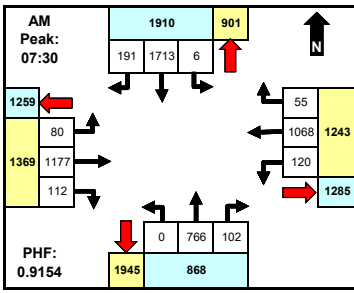

	North		East		South		West		Total
	App	Dep	App	Dep	App	Dep	App	Dep	
AM	1910	901	1243	1285	868	1945	1369	1259	5390
MID	993	1056	897	959	1061	1057	1038	917	3989
PM	1010	2162	1183	1806	2072	1146	1878	1029	6143
Total	7452	7766	6015	7407	7549	7910	7930	5863	28946

Comments

Unless shown otherwise, MID period defined as 10:00 AM - 2:00 PM. Peaks defined based on total intersection volume for all vehicle types.

Time	From North (SB)		From East (WB)		From South (NB)		From West (EB)		INTSEC	TOTAL								
	N 7TH ST		E THOMAS RD		N 7TH ST		E THOMAS RD											
	LT	Thru	RT	U	LT	Thru	RT	U										
0:00										0								
0:15										0								
0:30										0								
0:45										0								
1:00										0								
1:15										0								
1:30										0								
1:45										0								
2:00										0								
2:15										0								
2:30										0								
2:45										0								
3:00										0								
3:15										0								
3:30										0								
3:45										0								
4:00										0								
4:15										0								
4:30										0								
4:45										0								
5:00										0								
5:15										0								
5:30										0								
5:45										0								
6:00										0								
6:15										0								
6:30	1	303	24	0	12	126	10	0	0	104	13	0	9	180	19	0	801	
6:45	1	333	32	0	17	159	9	0	0	89	10	0	10	206	30	0	896	
7:00	1	394	31	0	25	156	8	0	0	165	14	0	19	206	15	0	1034	
7:15	1	407	38	0	19	228	11	0	0	159	25	0	21	279	33	0	1221	
7:30	3	453	36	0	30	242	11	0	0	182	15	0	16	278	26	0	1292	
7:45	0	433	52	0	32	238	13	0	0	224	38	0	21	329	32	0	1472	
8:00	2	436	62	0	29	242	14	0	0	190	22	0	20	269	25	0	1311	
8:15	1	391	41	0	29	286	17	0	0	170	27	0	23	301	29	0	1315	
8:30																	0	0
8:45																	0	0
9:00																	0	0
9:15																	0	0
9:30																	0	0
9:45																	0	0
10:00																	0	0
10:15																	0	0
10:30																	0	0
10:45																	0	0
11:00	18	169	23	1	34	164	24	0	31	186	30	0	26	182	38	0	926	
11:15	15	185	23	1	24	143	24	0	36	191	31	0	24	181	38	0	916	
11:30	18	147	24	0	34	153	25	0	29	162	31	1	24	182	48	0	878	
11:45	20	200	24	0	29	171	21	0	33	211	27	0	39	202	26	0	1003	
12:00	13	190	33	0	23	152	33	0	38	201	25	0	33	211	39	0	991	
12:15	24	197	22	0	29	184	26	0	19	207	27	0	30	183	42	0	990	
12:30	16	225	29	0	28	178	23	0	34	202	37	0	30	174	29	0	1005	
12:45	25	221	32	0	35	163	21	0	31	191	31	0	31	164	37	0	982	
13:00																	0	0
13:15																	0	0
13:30																	0	0
13:45																	0	0
14:00																	0	0
14:15																	0	0
14:30																	0	0
14:45																	0	0
15:00																	0	0
15:15																	0	0
15:30																	0	0
15:45																	0	0
16:00	5	239	45	0	27	166	29	0	10	397	36	0	44	328	31	0	1357	
16:15	0	213	26	0	28	254	38	0	5	427	39	0	41	430	35	0	1536	
16:30	0	230	27	0	33	228	34	0	1	473	59	0	41	354	25	0	1505	
16:45	0	231	30	0	33	265	50	0	2	456	48	0	37	403	25	0	1580	
17:00	0	233	20	0	32	170	18	0	1	488	73	0	59	400	28	0	1522	
17:15	1	221	36	0	21	204	26	0	3	496	42	0	49	370	30	0	1499	
17:30	0	222	23	0	30	228	27	0	5	465	42	0	56	358	32	0	1488	
17:45	0	236	41	0	29	248	33	0	3	450	39	0	30	291	24	0	1426	
18:00																	0	0
18:15																	0	0
18:30																	0	0
18:45																	0	0
19:00																	0	0
19:15																	0	0
19:30																	0	0
19:45																	0	0
20:00																	0	0
20:15																	0	0
20:30																	0	0
20:45																	0	0
21:00																	0	0
21:15																	0	0
21:30																	0	0
21:45																	0	0
22:00																	0	0
22:15																	0	0
22:30																	0	0
22:45																	0	0
23:00																	0	0
23:15																	0	0
23:30																	0	0
23:45																	0	0
Total	165	6511	774	2	662	4808	545	0	281	6486	781	1	733	6461	736	0	28946	
AM Peak Hr:																	7:30	
PK Vol	6	1713	191	0	120	1068	55	0	0	766	102	0	80	1177	112	0	5390	
PHF	0.500	0.945	0.770	n/a	0.938	0.896	0.809	n/a	n/a	0.855	0.671	n/a	0.870	0.894	0.875	n/a	0.915	
MID Peak Hr:																	11:45	
PK Vol	73	812	108	0	109	685	103	0	124	821	116	0	132	770	136	0	3989	
PHF	0.760	0.902	0.818	n/a	0.940	0.931	0.780	n/a	0.816	0.973	0.784	n/a	0.846	0.912	0.810	n/a	0.992	
PM Peak Hr:																	16:15	
PK Vol	0	907	103	0	126	917	140	0	9	1844	219	0	178	1587	113	0	6143	
PHF	n/a	0.973	0.858	n/a	0.955	0.865	0.700	n/a	0.450	0.945	0.750	n/a	0.754	0.923	0.807	n/a	0.972	

Intersection ID: 1805128
Count Date: 11/29/2018

N 7TH ST & E THOMAS RD

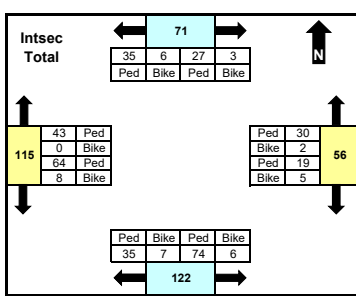
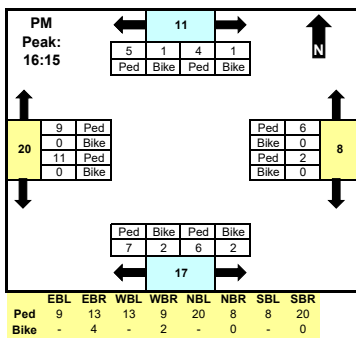
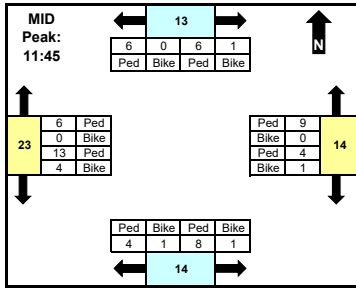
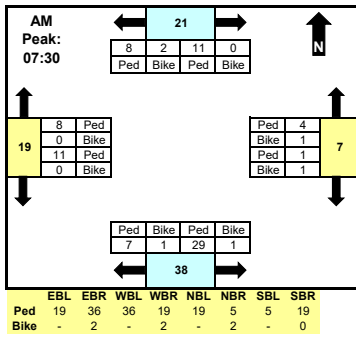

	North		East		South		West		Total
	CW	CCW	CW	CCW	CW	CCW	CW	CCW	
AM	11	10	2	5	8	30	8	11	85
MID	7	6	5	9	5	9	6	17	64
PM	5	6	2	6	9	8	9	11	56
Total	30	41	24	32	42	80	43	72	364

CW = Clockwise
CCW = Counter-clockwise

Comments

Unless shown otherwise, MID period defined as 10:00 AM - 2:00 PM. Crosswalk peaks defined based on total intersection volume for all vehicle types.

Time	North Leg		East Leg		South Leg		West Leg		INTSEC	TOTAL							
	CW	CCW	CW	CCW	CW	CCW	CW	CCW									
0:00										0							
0:15										0							
0:30										0							
0:45										0							
1:00										0							
1:15										0							
1:30										0							
1:45										0							
2:00										0							
2:15										0							
2:30										0							
2:45										0							
3:00										0							
3:15										0							
3:30										0							
3:45										0							
4:00										0							
4:15										0							
4:30										0							
4:45										0							
5:00										0							
5:15										0							
5:30										0							
5:45										0							
6:00										0							
6:15										0							
6:30	0	0	2	0	2	0	1	0	0	2	3	0					
6:45	0	0	0	0	0	1	1	0	0	1	1	0					
7:00	0	0	0	0	2	0	0	0	0	4	0	0					
7:15	0	0	4	0	4	0	0	0	5	1	2	0					
7:30	2	0	0	2	0	0	1	1	1	9	1	2					
7:45	7	0	2	0	0	1	2	0	2	0	10	0					
8:00	1	0	6	0	1	0	1	0	4	0	5	0					
8:15	1	0	0	0	0	0	1	0	0	0	5	0					
8:30																	
8:45																	
9:00																	
9:15																	
9:30																	
9:45																	
10:00																	
10:15																	
10:30																	
10:45																	
11:00	0	1	2	1	0	0	1	0	0	0	4	0					
11:15	0	0	0	1	2	1	0	0	1	0	1	0					
11:30	0	0	1	1	0	1	1	0	2	1	1	0					
11:45	2	0	1	0	0	0	1	0	2	0	1	0					
12:00	1	0	0	0	2	1	1	0	0	1	2	0					
12:15	2	1	2	0	0	0	7	0	1	0	4	0					
12:30	1	0	3	0	2	0	0	0	1	0	1	1					
12:45	1	0	1	0	0	0	1	0	1	0	3	0					
13:00																	
13:15																	
13:30																	
13:45																	
14:00																	
14:15																	
14:30																	
14:45																	
15:00																	
15:15																	
15:30																	
15:45	2	0	2	0	2	0	2	0	3	0	3	2					
16:00	0	0	0	0	0	0	3	0	2	0	0	1					
16:15	0	0	0	0	0	0	3	0	2	0	0	1					
16:30	3	0	1	0	0	0	2	0	0	1	6	1					
16:45	0	1	3	1	2	0	1	0	5	1	0	0					
17:00	1	0	1	0	0	0	0	0	0	0	0	2					
17:15	1	0	0	0	0	0	2	1	0	0	4	0					
17:30	1	0	4	0	0	0	1	0	2	0	1	0					
17:45	1	0	0	0	0	0	1	0	2	0	5	0					
18:00																	
18:15																	
18:30																	
18:45																	
19:00																	
19:15																	
19:30																	
19:45																	
20:00																	
20:15																	
20:30																	
20:45																	
21:00																	
21:15																	
21:30																	
21:45																	
22:00																	
22:15																	
22:30																	
22:45																	
23:00																	
23:15																	
23:30																	
23:45																	
Total	27	3	35	6	19	5	30	2	35	7	74	6	43	0	64	8	364
AM Peak Hr:																	7:30
PK Vol	11	0	8	2	1	1	4	1	7	1	29	1	8	0	11	0	85
MID Peak Hr:																	11:45
PK Vol	6	1	6	0	4	1	9	0	4	1	8	1	6	0	13	4	64
PM Peak Hr:																	16:15
PK Vol	4	1	5	1	2	0	6	0	7	2	6	2	9	0	11	0	55

Intersection ID: 1805128
Count Date: 11/29/2018

N 7TH ST & E THOMAS RD

From North (SB) From East (WB) From South (NB) From West (EB) INTSEC
N 7TH ST E THOMAS RD N 7TH ST E THOMAS RD

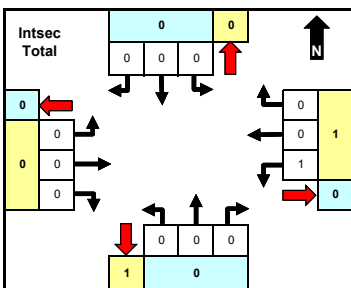
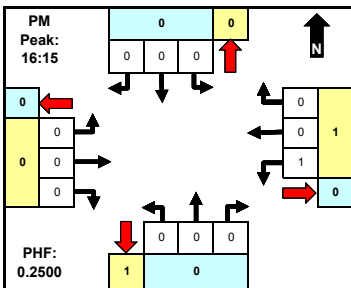
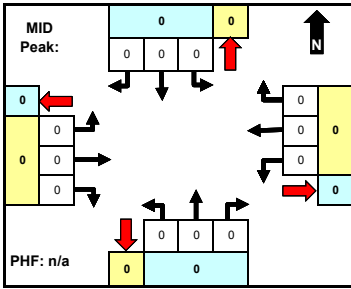
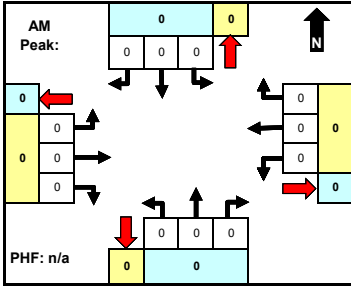

	North		East		South		West		Total
	App	Dep	App	Dep	App	Dep	App	Dep	
AM	0	0	0	0	0	0	0	0	0
MID	0	0	0	0	0	0	0	0	0
PM	0	0	1	0	0	1	0	0	1
Total	0	0	1	0	0	1	0	0	1

Comments

Unless shown otherwise, MID period defined as 10:00 AM - 2:00 PM. Peaks defined based on total intersection volume for all vehicle types.

Time	From North (SB)				From East (WB)				From South (NB)				From West (EB)				INTSEC
	LT	Thru	RT	U	LT	Thru	RT	U	LT	Thru	RT	U	LT	Thru	RT	U	
0:00																	0
0:15																	0
0:30																	0
0:45																	0
1:00																	0
1:15																	0
1:30																	0
1:45																	0
2:00																	0
2:15																	0
2:30																	0
2:45																	0
3:00																	0
3:15																	0
3:30																	0
3:45																	0
4:00																	0
4:15																	0
4:30																	0
4:45																	0
5:00																	0
5:15																	0
5:30																	0
5:45																	0
6:00																	0
6:15																	0
6:30	0	0	0	0	0	0	0	0	0	0	0	0	0	0	0	0	
6:45	0	0	0	0	0	0	0	0	0	0	0	0	0	0	0	0	
7:00	0	0	0	0	0	0	0	0	0	0	0	0	0	0	0	0	
7:15	0	0	0	0	0	0	0	0	0	0	0	0	0	0	0	0	
7:30	0	0	0	0	0	0	0	0	0	0	0	0	0	0	0	0	
7:45	0	0	0	0	0	0	0	0	0	0	0	0	0	0	0	0	
8:00	0	0	0	0	0	0	0	0	0	0	0	0	0	0	0	0	
8:15	0	0	0	0	0	0	0	0	0	0	0	0	0	0	0	0	
8:30																	0
8:45																	0
9:00																	0
9:15																	0
9:30																	0
9:45																	0
10:00																	0
10:15																	0
10:30																	0
10:45																	0
11:00	0	0	0	0	0	0	0	0	0	0	0	0	0	0	0	0	
11:15	0	0	0	0	0	0	0	0	0	0	0	0	0	0	0	0	
11:30	0	0	0	0	0	0	0	0	0	0	0	0	0	0	0	0	
11:45	0	0	0	0	0	0	0	0	0	0	0	0	0	0	0	0	
12:00	0	0	0	0	0	0	0	0	0	0	0	0	0	0	0	0	
12:15	0	0	0	0	0	0	0	0	0	0	0	0	0	0	0	0	
12:30	0	0	0	0	0	0	0	0	0	0	0	0	0	0	0	0	
12:45	0	0	0	0	0	0	0	0	0	0	0	0	0	0	0	0	
13:00																	0
13:15																	0
13:30																	0
13:45																	0
14:00																	0
14:15																	0
14:30																	0
14:45																	0
15:00																	0
15:15																	0
15:30																	0
15:45																	0
16:00	0	0	0	0	0	0	0	0	0	0	0	0	0	0	0	0	
16:15	0	0	0	0	0	0	0	0	0	0	0	0	0	0	0	0	
16:30	0	0	0	0	1	0	0	0	0	0	0	0	0	0	0	1	
16:45	0	0	0	0	0	0	0	0	0	0	0	0	0	0	0	0	
17:00	0	0	0	0	0	0	0	0	0	0	0	0	0	0	0	0	
17:15	0	0	0	0	0	0	0	0	0	0	0	0	0	0	0	0	
17:30	0	0	0	0	0	0	0	0	0	0	0	0	0	0	0	0	
17:45	0	0	0	0	0	0	0	0	0	0	0	0	0	0	0	0	
18:00	0	0	0	0	0	0	0	0	0	0	0	0	0	0	0	0	
18:15																	0
18:30																	0
18:45																	0
19:00																	0
19:15																	0
19:30																	0
19:45																	0
20:00																	0
20:15																	0
20:30																	0
20:45																	0
21:00																	0
21:15																	0
21:30																	0
21:45																	0
22:00																	0
22:15																	0
22:30																	0
22:45																	0
23:00																	0
23:15																	0
23:30																	0
23:45																	0
Total	0	0	0	0	1	0	0	0	0	0	0	0	0	0	0	1	1
AM Peak Hr:																	7:30
Pk Vol	0	0	0	0	0	0	0	0	0	0	0	0	0	0	0	0	0
PHF	n/a	n/a	n/a	n/a	n/a	n/a	n/a	n/a	n/a	n/a	n/a	n/a	n/a	n/a	n/a	n/a	n/a
MID Peak Hr:																	11:45
Pk Vol	0	0	0	0	0	0	0	0	0	0	0	0	0	0	0	0	0
PHF	n/a	n/a	n/a	n/a	n/a	n/a	n/a	n/a	n/a	n/a	n/a	n/a	n/a	n/a	n/a	n/a	n/a
PM Peak Hr:																	16:15
Pk Vol	0	0	0	0	1	0	0	0	0	0	0	0	0	0	0	0	1
PHF	n/a	n/a	n/a	n/a	0.250	n/a	n/a	n/a	n/a	n/a	n/a	n/a	n/a	n/a	n/a	n/a	0.250

Intersection ID: 1805129
 Count Date: 11/29/2018

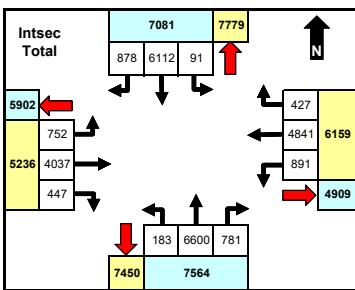
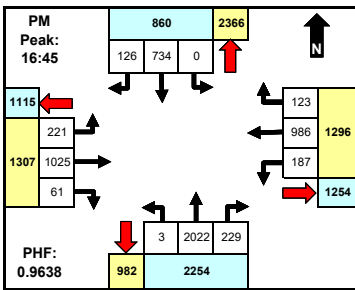
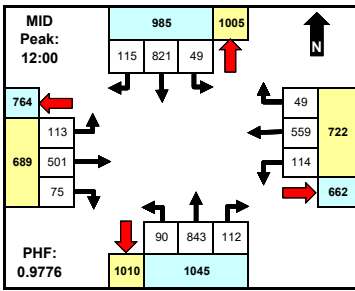
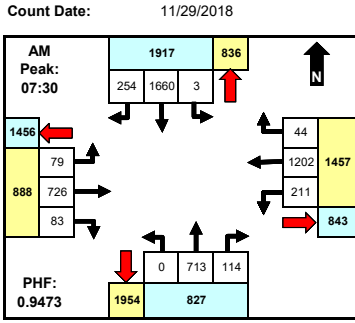
N 7TH ST & E OSBORN RD

	North		East		South		West		Total
	App	Dep	App	Dep	App	Dep	App	Dep	
AM	1917	836	1457	843	827	1954	888	1456	5089
MID	985	1005	722	662	1045	1010	689	764	3441
PM	860	2366	1296	1254	2254	982	1307	1115	5717
Total	7081	7779	6159	4909	7564	7450	5236	5902	26040

Comments

Unless shown otherwise, MID period defined as 10:00 AM - 2:00 PM. Peaks defined based on total intersection volume for all vehicle types.

Time	From North (SB)				From East (WB)				From South (NB)				From West (EB)				INTSEC	TOTAL
	N 7TH AVE				E OSBORN RD				N 7TH AVE				E OSBORN RD					
	LT	Thru	RT	U	LT	Thru	RT	U	LT	Thru	RT	U	LT	Thru	RT	U		
0:00																	0	
0:15																	0	
0:30																	0	
0:45																	0	
1:00																	0	
1:15																	0	
1:30																	0	
1:45																	0	
2:00																	0	
2:15																	0	
2:30																	0	
2:45																	0	
3:00																	0	
3:15																	0	
3:30																	0	
3:45																	0	
4:00																	0	
4:15																	0	
4:30																	0	
4:45																	0	
5:00																	0	
5:15																	0	
5:30																	0	
5:45																	0	
6:00																	0	
6:15																	0	
6:30	0	278	30	0	17	117	2	0	0	94	7	0	9	85	17	0	656	
6:45	2	358	38	0	26	134	10	0	0	95	10	0	10	86	13	0	782	
7:00	0	366	43	0	32	175	5	0	0	148	8	0	10	130	17	0	934	
7:15	0	441	52	0	45	254	9	0	0	160	20	0	11	125	21	0	1138	
7:30	0	426	49	0	44	308	10	0	0	159	33	0	15	195	23	0	1262	
7:45	0	450	71	0	55	302	12	0	0	191	35	0	26	178	23	0	1343	
8:00	1	384	64	0	65	325	11	0	0	175	20	0	20	201	19	0	1285	
8:15	2	400	70	0	47	267	11	0	0	188	26	0	18	152	18	0	1199	
8:30																	0	
8:45																	0	
9:00																	0	
9:15																	0	
9:30																	0	
9:45																	0	
10:00																	0	
10:15																	0	
10:30																	0	
10:45																	0	
11:00	8	175	12	0	21	110	18	0	21	188	22	0	24	91	17	0	707	
11:15	11	177	23	0	23	89	11	0	22	170	21	0	28	114	28	0	717	
11:30	9	153	25	0	22	112	15	0	24	178	27	0	18	113	22	0	718	
11:45	9	190	33	0	21	111	10	0	18	214	18	0	29	111	31	0	795	
12:00	8	185	30	0	29	141	11	0	21	224	29	0	36	136	16	0	866	
12:15	16	199	32	0	18	123	9	0	25	205	30	0	29	133	23	0	842	
12:30	13	196	28	0	37	147	16	0	23	210	21	0	30	112	20	0	853	
12:45	12	241	25	0	30	148	13	0	21	204	32	0	18	120	16	0	880	
13:00																	0	
13:15																	0	
13:30																	0	
13:45																	0	
14:00																	0	
14:15																	0	
14:30																	0	
14:45																	0	
15:00																	0	
15:15																	0	
15:30																	0	
15:45																	0	
16:00	0	214	36	0	45	273	29	0	2	391	48	0	55	229	12	0	1334	
16:15	0	179	32	0	29	252	30	0	0	468	59	0	52	247	13	0	1361	
16:30	0	158	23	0	40	221	53	0	0	477	47	0	51	268	19	0	1357	
16:45	0	195	21	0	51	248	34	0	0	505	68	0	54	230	11	0	1417	
17:00	0	175	32	0	43	267	35	0	0	502	52	0	56	305	16	0	1483	
17:15	0	184	45	0	49	209	32	0	1	540	62	0	59	238	16	0	1435	
17:30	0	180	28	0	44	262	22	0	2	475	47	0	52	252	18	0	1382	
17:45	0	208	36	0	58	246	19	0	3	439	39	0	42	186	18	0	1294	
18:00																	0	
18:15																	0	
18:30																	0	
18:45																	0	
19:00																	0	
19:15																	0	
19:30																	0	
19:45																	0	
20:00																	0	
20:15																	0	
20:30																	0	
20:45																	0	
21:00																	0	
21:15																	0	
21:30																	0	
21:45																	0	
22:00																	0	
22:15																	0	
22:30																	0	
22:45																	0	
23:00																	0	
23:15																	0	
23:30																	0	
23:45																	0	
Total	91	6112	878	0	891	4841	427	0	183	6600	781	0	752	4037	447	0	26040	
AM Peak Hr:																	7:30	
PK Vol	3	1660	254	0	211	1202	44	0	0	713	114	0	79	726	83	0	5089	
PHF	0.375	0.922	0.894	n/a	0.812	0.925	0.917	n/a	n/a	0.933	0.814	n/a	0.760	0.903	0.902	n/a	0.947	
MID Peak Hr:																	12:00	
PK Vol	49	821	115	0	114	559	49	0	90	843	112	0	113	501	75	0	3441	
PHF	0.766	0.852	0.895	n/a	0.770	0.944	0.766	n/a	0.900	0.941	0.875	n/a	0.785	0.921	0.815	n/a	0.978	
PM Peak Hr:																	16:45	
PK Vol	0	734	126	0	187	986	123	0	3	2022	229	0	221	1025	61	0	5717	
PHF	n/a	0.941	0.700	n/a	0.917	0.923	0.879	n/a	0.375	0.936	0.842	n/a	0.936	0.840	0.847	n/a	0.954	

Intersection ID: 1805129
Count Date: 11/29/2018

N 7TH AVE & E OSBORN RD

From North (SB) From East (WB) From South (NB) From West (EB) INTSEC
N 7TH AVE E OSBORN RD N 7TH AVE E OSBORN RD

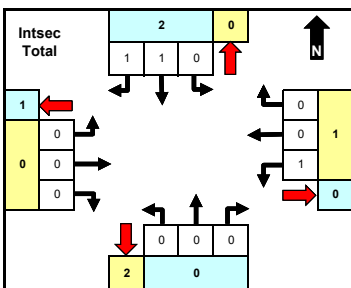
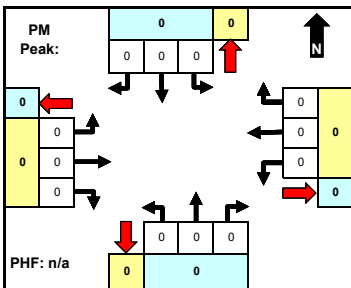
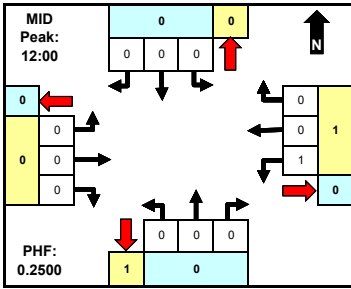
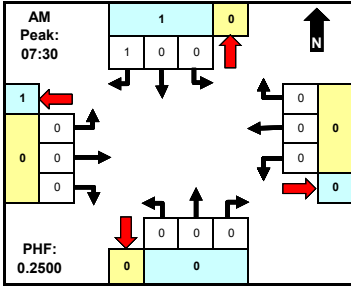

	North		East		South		West		Total
	App	Dep	App	Dep	App	Dep	App	Dep	
AM	1	0	0	0	0	0	0	0	1
MID	0	0	1	0	0	1	0	0	1
PM	0	0	0	0	0	0	0	0	0
Total	2	0	1	0	0	2	0	1	3

Comments
Unless shown otherwise, MID period defined as 10:00 AM - 2:00 PM. Peaks defined based on total intersection volume for all vehicle types.

Time	From North (SB)				From East (WB)				From South (NB)				From West (EB)				TOTAL
	LT	Thru	RT	U	LT	Thru	RT	U	LT	Thru	RT	U	LT	Thru	RT	U	
0:00																	0
0:15																	0
0:30																	0
0:45																	0
1:00																	0
1:15																	0
1:30																	0
1:45																	0
2:00																	0
2:15																	0
2:30																	0
2:45																	0
3:00																	0
3:15																	0
3:30																	0
3:45																	0
4:00																	0
4:15																	0
4:30																	0
4:45																	0
5:00																	0
5:15																	0
5:30																	0
5:45																	0
6:00																	0
6:15																	0
6:30	0	0	0	0	0	0	0	0	0	0	0	0	0	0	0	0	0
6:45	0	0	0	0	0	0	0	0	0	0	0	0	0	0	0	0	0
7:00	0	0	0	0	0	0	0	0	0	0	0	0	0	0	0	0	0
7:15	0	0	0	0	0	0	0	0	0	0	0	0	0	0	0	0	0
7:30	0	0	0	0	0	0	0	0	0	0	0	0	0	0	0	0	0
7:45	0	0	0	0	0	0	0	0	0	0	0	0	0	0	0	0	0
8:00	0	0	0	0	0	0	0	0	0	0	0	0	0	0	0	0	0
8:15	0	0	1	0	0	0	0	0	0	0	0	0	0	0	0	0	1
8:30																	0
8:45																	0
9:00																	0
9:15																	0
9:30																	0
9:45																	0
10:00																	0
10:15																	0
10:30																	0
10:45																	0
11:00	0	0	0	0	0	0	0	0	0	0	0	0	0	0	0	0	0
11:15	0	0	0	0	0	0	0	0	0	0	0	0	0	0	0	0	0
11:30	0	0	0	0	0	0	0	0	0	0	0	0	0	0	0	0	0
11:45	0	0	0	0	0	0	0	0	0	0	0	0	0	0	0	0	0
12:00	0	0	0	0	0	0	0	0	0	0	0	0	0	0	0	0	0
12:15	0	0	0	0	0	1	0	0	0	0	0	0	0	0	0	0	1
12:30	0	0	0	0	0	0	0	0	0	0	0	0	0	0	0	0	0
12:45	0	0	0	0	0	0	0	0	0	0	0	0	0	0	0	0	0
13:00																	0
13:15																	0
13:30																	0
13:45																	0
14:00																	0
14:15																	0
14:30																	0
14:45																	0
15:00																	0
15:15																	0
15:30																	0
15:45																	0
16:00	0	1	0	0	0	0	0	0	0	0	0	0	0	0	0	0	1
16:15	0	0	0	0	0	0	0	0	0	0	0	0	0	0	0	0	0
16:30	0	0	0	0	0	0	0	0	0	0	0	0	0	0	0	0	0
16:45	0	0	0	0	0	0	0	0	0	0	0	0	0	0	0	0	0
17:00	0	0	0	0	0	0	0	0	0	0	0	0	0	0	0	0	0
17:15	0	0	0	0	0	0	0	0	0	0	0	0	0	0	0	0	0
17:30	0	0	0	0	0	0	0	0	0	0	0	0	0	0	0	0	0
17:45	0	0	0	0	0	0	0	0	0	0	0	0	0	0	0	0	0
18:00	0	0	0	0	0	0	0	0	0	0	0	0	0	0	0	0	0
18:15																	0
18:30																	0
18:45																	0
19:00																	0
19:15																	0
19:30																	0
19:45																	0
20:00																	0
20:15																	0
20:30																	0
20:45																	0
21:00																	0
21:15																	0
21:30																	0
21:45																	0
22:00																	0
22:15																	0
22:30																	0
22:45																	0
23:00																	0
23:15																	0
23:30																	0
23:45																	0
Total	0	1	1	0	0	1	0	0	0	0	0	0	0	0	0	0	3
AM Peak Hr:																	7:30
Pk Vol	0	0	1	0	0	0	0	0	0	0	0	0	0	0	0	0	1
PHF	n/a	n/a	0.250	n/a	n/a	n/a	n/a	n/a	n/a	n/a	n/a	n/a	n/a	n/a	n/a	n/a	0.250
MID Peak Hr:																	12:00
Pk Vol	0	0	0	1	0	0	0	0	0	0	0	0	0	0	0	0	1
PHF	n/a	n/a	n/a	0.250	n/a	n/a	n/a	n/a	n/a	n/a	n/a	n/a	n/a	n/a	n/a	n/a	0.250
PM Peak Hr:																	16:45
Pk Vol	0	0	0	0	0	0	0	0	0	0	0	0	0	0	0	0	0
PHF	n/a	n/a	n/a	n/a	n/a	n/a	n/a	n/a	n/a	n/a	n/a	n/a	n/a	n/a	n/a	n/a	n/a

Intersection ID: 1805129
Count Date: 11/29/2018

N 7TH AVE & E OSBORN RD

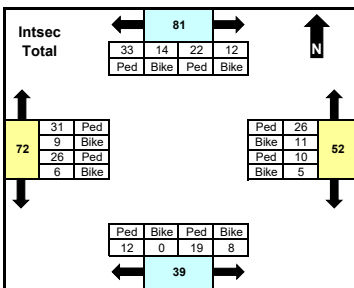
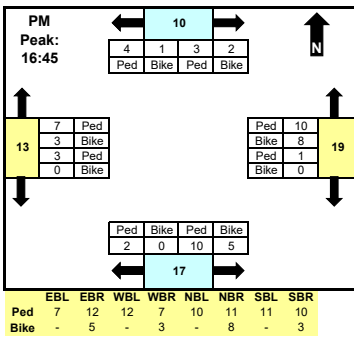
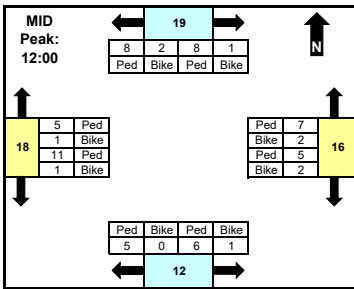
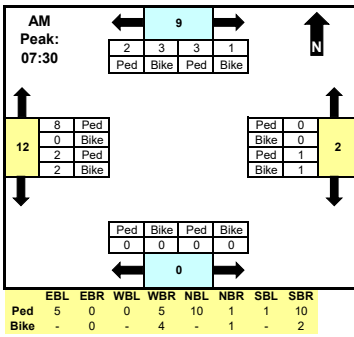

	North		East		South		West		Total
	CW	CCW	CW	CCW	CW	CCW	CW	CCW	
AM	4	5	2	0	0	0	8	4	23
MID	9	10	7	9	5	7	6	12	65
PM	5	5	1	18	2	15	10	3	59
Total	34	47	15	37	12	27	40	32	244

CW = Clockwise
CCW = Counter-clockwise

Comments
Unless shown otherwise, MID period defined as 10:00 AM - 2:00 PM. Crosswalk peaks defined based on total intersection volume for all vehicle types.

Time	North Leg		East Leg		South Leg		West Leg		INTSEC	TOTAL							
	CW	CCW	CW	CCW	CW	CCW	CW	CCW									
0:00										0							
0:15										0							
0:30										0							
0:45										0							
1:00										0							
1:15										0							
1:30										0							
1:45										0							
2:00										0							
2:15										0							
2:30										0							
2:45										0							
3:00										0							
3:15										0							
3:30										0							
3:45										0							
4:00										0							
4:15										0							
4:30										0							
4:45										0							
5:00										0							
5:15										0							
5:30										0							
5:45										0							
6:00										0							
6:15										0							
6:30	2	0	0	0	0	0	0	0	0	2							
6:45	1	0	0	0	0	0	0	0	0	1							
7:00	0	0	5	2	0	0	0	0	1	10							
7:15	0	1	0	0	2	0	0	0	0	4							
7:30	1	0	1	0	1	0	0	0	1	5							
7:45	2	1	1	2	1	1	0	0	2	10							
8:00	0	0	0	0	0	0	0	0	0	0							
8:15	0	0	0	1	0	0	0	0	0	1							
8:30										0							
8:45										0							
9:00										0							
9:15										0							
9:30										0							
9:45										0							
10:00										0							
10:15										0							
10:30										0							
10:45										0							
11:00	0	0	0	1	0	0	1	0	2	3							
11:15	1	0	1	0	0	0	1	0	3	1							
11:30	1	0	1	2	0	2	0	0	0	1							
11:45	1	1	2	0	0	0	0	0	3	2							
12:00	0	0	3	0	0	1	2	0	0	2							
12:15	3	0	2	0	4	0	3	1	0	7							
12:30	1	1	3	0	1	0	2	0	1	0							
12:45	4	0	0	2	0	1	0	1	4	2							
13:00										0							
13:15										0							
13:30										0							
13:45										0							
14:00										0							
14:15										0							
14:30										0							
14:45										0							
15:00										0							
15:15										0							
15:30										0							
15:45	0	2	2	0	1	0	2	0	1	0							
16:00	1	2	4	0	0	0	1	1	0	0							
16:15	0	1	4	2	0	0	3	0	0	2							
16:30	0	1	0	0	0	3	0	0	1	1							
16:45	0	1	0	0	0	6	1	0	5	1							
17:00	2	0	2	0	1	0	3	3	1	2							
17:15	0	1	0	1	0	0	1	3	1	3							
17:30	1	0	2	0	0	0	1	0	1	1							
17:45	1	1	0	1	0	0	1	0	0	0							
18:00										0							
18:15										0							
18:30										0							
18:45										0							
19:00										0							
19:15										0							
19:30										0							
19:45										0							
20:00										0							
20:15										0							
20:30										0							
20:45										0							
21:00										0							
21:15										0							
21:30										0							
21:45										0							
22:00										0							
22:15										0							
22:30										0							
22:45										0							
23:00										0							
23:15										0							
23:30										0							
23:45										0							
Total	22	12	33	14	10	5	26	11	12	0	19	8	31	9	26	6	244
AM Peak Hr:																	7:30
PK Vol	3	1	2	3	1	1	0	0	0	0	0	0	0	8	0	2	23
MID Peak Hr:																	12:00
PK Vol	8	1	8	2	5	2	7	2	5	0	6	1	5	1	11	1	65
PM Peak Hr:																	16:45
PK Vol	3	2	4	1	1	0	10	8	2	0	10	5	7	3	3	0	59

Intersection ID: 1805130
Count Date: 11/29/2018

N 7TH ST & E INDIAN SCHOOL RD

From North (SB) From East (WB) From South (NB) From West (EB)
N 7TH ST E INDIAN SCHOOL RD N 7TH ST E INDIAN SCHOOL RD INTSEC

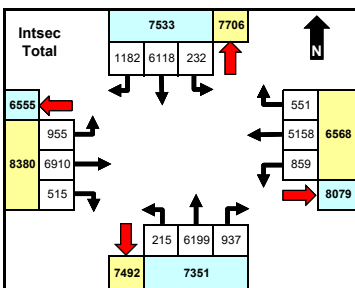
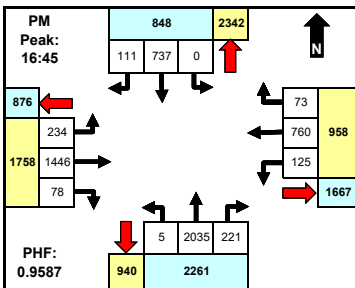
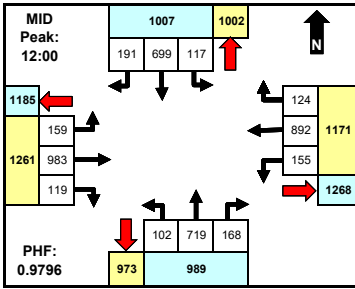
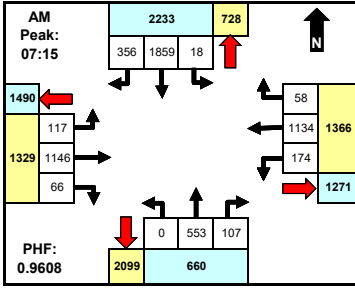

	North		East		South		West		Total
	App	Dep	App	Dep	App	Dep	App	Dep	
AM	2233	728	1366	1271	660	2099	1329	1490	5588
MID	1007	1002	1171	1268	989	973	1261	1185	4428
PM	848	2342	958	1667	2261	940	1758	876	5825
Total	7533	7706	6568	8079	7351	7492	8380	6555	29832

Time	LT	Thru	RT	U	LT	Thru	RT	U	LT	Thru	RT	U	LT	Thru	RT	U	TOTAL
0:00																	0
0:15																	0
0:30																	0
0:45																	0
1:00																	0
1:15																	0
1:30																	0
1:45																	0
2:00																	0
2:15																	0
2:30																	0
2:45																	0
3:00																	0
3:15																	0
3:30																	0
3:45																	0
4:00																	0
4:15																	0
4:30																	0
4:45																	0
5:00																	0
5:15																	0
5:30																	0
5:45																	0
6:00																	0
6:15																	0
6:30	2	306	42	0	28	164	26	0	0	79	12	0	12	219	16	0	906
6:45	1	366	60	0	33	197	17	0	0	82	20	0	11	246	19	0	1052
7:00	0	438	72	0	23	228	17	0	0	110	20	0	18	257	12	0	1195
7:15	6	433	78	0	43	280	18	0	0	116	19	0	29	286	14	0	1322
7:30	6	487	83	0	41	266	12	0	0	145	33	0	28	253	14	0	1368
7:45	2	467	78	0	40	305	12	0	0	142	27	0	28	333	20	0	1454
8:00	4	472	117	0	50	283	16	0	0	150	28	0	32	274	18	0	1444
8:15	1	410	86	0	54	192	26	0	0	141	26	0	28	276	17	0	1257
8:30																	0
8:45																	0
9:00																	0
9:15																	0
9:30																	0
9:45																	0
10:00																	0
10:15																	0
10:30																	0
10:45																	0
11:00	17	139	39	0	27	191	30	0	25	169	28	0	33	207	26	0	931
11:15	30	154	38	1	35	219	24	0	32	138	38	0	36	236	24	0	1005
11:30	23	143	40	0	36	202	30	0	19	146	47	0	42	239	31	0	998
11:45	22	158	47	0	35	203	31	0	23	187	45	0	36	236	28	0	1051
12:00	25	179	51	0	30	220	33	0	26	165	54	0	41	266	28	0	1118
12:15	35	164	46	0	40	217	29	0	32	203	34	0	44	252	34	0	1130
12:30	29	172	48	0	46	224	33	0	24	184	39	0	40	227	30	0	1096
12:45	28	184	46	0	39	231	29	0	20	167	41	0	34	238	27	0	1084
13:00																	0
13:15																	0
13:30																	0
13:45																	0
14:00																	0
14:15																	0
14:30																	0
14:45																	0
15:00																	0
15:15																	0
15:30																	0
15:45																	0
16:00	1	188	0	0	41	214	33	0	0	418	49	0	54	373	20	0	1391
16:15	0	168	0	0	29	175	25	0	0	484	42	0	53	389	27	0	1392
16:30	0	143	48	0	26	161	17	0	3	503	57	0	71	353	11	0	1393
16:45	0	182	58	0	30	196	19	0	0	512	43	0	54	334	20	0	1448
17:00	0	174	0	0	24	187	24	0	4	480	70	0	58	369	18	0	1408
17:15	0	203	0	0	31	173	15	0	0	542	54	0	62	420	19	0	1519
17:30	0	178	53	0	40	204	15	0	1	501	54	0	60	323	21	0	1460
17:45	0	210	52	0	38	226	20	0	6	435	57	0	51	304	21	0	1420
18:00																	0
18:15																	0
18:30																	0
18:45																	0
19:00																	0
19:15																	0
19:30																	0
19:45																	0
20:00																	0
20:15																	0
20:30																	0
20:45																	0
21:00																	0
21:15																	0
21:30																	0
21:45																	0
22:00																	0
22:15																	0
22:30																	0
22:45																	0
23:00																	0
23:15																	0
23:30																	0
23:45																	0
Total	232	6118	1182	1	859	5158	551	0	215	6199	937	0	955	6910	515	0	29832

Comments

Unless shown otherwise, MID period defined as 10:00 AM - 2:00 PM. Peaks defined based on total intersection volume for all vehicle types.

AM Peak Hr:	7:15																
Pk Vol	18	1859	356	0	174	1134	58	0	0	553	107	0	117	1146	66	0	5588
PHF	0.750	0.954	0.761	n/a	0.870	0.930	0.806	n/a	n/a	0.922	0.811	n/a	0.914	0.860	0.825	n/a	0.961
MID Peak Hr:	12:00																
Pk Vol	177	899	191	0	155	892	124	0	102	749	168	0	159	983	119	0	4428
PHF	0.836	0.950	0.936	n/a	0.842	0.965	0.939	n/a	0.797	0.885	0.778	n/a	0.903	0.924	0.875	n/a	0.960
PM Peak Hr:	16:45																
Pk Vol	0	737	111	0	126	760	73	0	5	2035	221	0	234	1446	78	0	5825
PHF	n/a	0.908	0.478	n/a	0.781	0.931	0.760	n/a	0.313	0.939	0.789	n/a	0.944	0.861	0.929	n/a	0.959

Intersection ID: 1805130
Count Date: 11/29/2018

N 7TH ST & E INDIAN SCHOOL RD

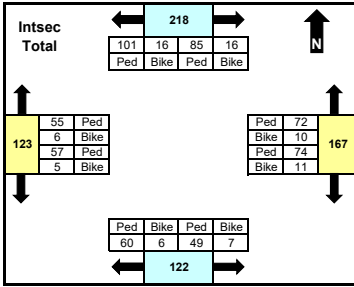
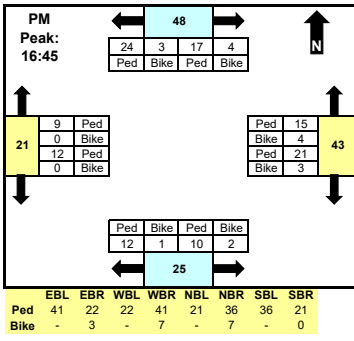
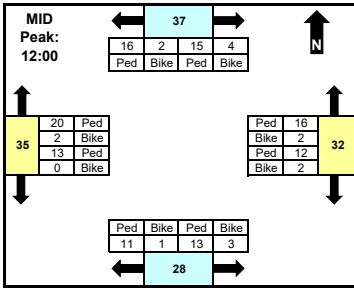
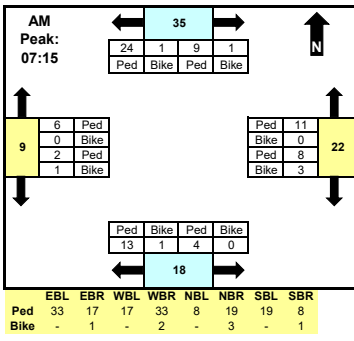

	North		East		South		West		Total
	CW	CCW	CW	CCW	CW	CCW	CW	CCW	
AM	10	25	11	11	14	4	6	3	84
MID	19	18	14	18	12	16	22	13	132
PM	21	27	24	19	13	12	9	12	137
Total	101	117	85	82	66	56	61	62	630

CW = Clockwise
CCW = Counter-clockwise

Comments
Unless shown otherwise, MID period defined as 10:00 AM - 2:00 PM. Crosswalk peaks defined based on total intersection volume for all vehicle types.

Time	North Leg		East Leg		South Leg		West Leg		INTSEC	TOTAL							
	CW	CCW	CW	CCW	CW	CCW	CW	CCW									
0:00										0							
0:15										0							
0:30										0							
0:45										0							
1:00										0							
1:15										0							
1:30										0							
1:45										0							
2:00										0							
2:15										0							
2:30										0							
2:45										0							
3:00										0							
3:15										0							
3:30										0							
3:45										0							
4:00										0							
4:15										0							
4:30										0							
4:45										0							
5:00										0							
5:15										0							
5:30										0							
5:45										0							
6:00										0							
6:15										0							
6:30	0	0	5	0	2	0	2	0	0	0	1	10					
6:45	3	0	2	1	0	0	1	0	2	0	3	0	14				
7:00	1	0	1	0	1	0	2	0	1	0	1	0	0	11			
7:15	2	0	8	0	2	0	7	0	1	0	0	0	0	20			
7:30	2	0	4	1	1	0	3	0	4	0	1	0	2	19			
7:45	3	0	4	0	2	3	0	0	2	1	2	0	1	20			
8:00	2	1	8	0	3	0	1	0	6	0	1	0	3	25			
8:15	2	0	0	0	2	0	4	0	2	1	2	0	1	15			
8:30														0			
8:45														0			
9:00														0			
9:15														0			
9:30														0			
9:45														0			
10:00														0			
10:15														0			
10:30														0			
10:45														0			
11:00	5	0	4	3	2	0	3	0	4	0	3	0	5	3	33		
11:15	6	2	5	0	1	2	2	0	2	0	1	0	2	2	28		
11:30	4	2	3	1	0	0	2	1	1	0	3	0	3	0	27		
11:45	3	0	1	1	3	0	1	1	2	0	1	1	1	0	20		
12:00	4	2	6	0	3	1	3	0	3	0	4	0	5	1	33		
12:15	3	0	2	1	2	1	2	1	0	0	2	0	2	0	24		
12:30	4	2	3	1	5	0	4	1	4	1	4	2	8	1	44		
12:45	4	0	5	0	2	0	7	0	4	0	3	1	5	0	31		
13:00														0			
13:15														0			
13:30														0			
13:45														0			
14:00														0			
14:15														0			
14:30														0			
14:45														0			
15:00														0			
15:15														0			
15:30														0			
15:45														0			
16:00	6	1	4	0	4	0	0	1	3	0	2	1	1	0	27		
16:15	3	1	7	4	5	0	7	1	3	2	9	0	1	0	49		
16:30	9	1	4	0	7	0	1	0	2	0	0	0	0	1	26		
16:45	4	1	12	3	14	2	5	0	4	1	2	0	2	0	56		
17:00	8	1	3	0	2	0	8	0	2	0	5	0	0	1	30		
17:15	3	0	6	0	1	0	2	2	2	0	1	1	3	0	24		
17:30	2	2	3	0	4	1	0	2	4	0	2	1	4	0	27		
17:45	2	0	1	0	6	1	5	0	2	0	0	0	0	0	17		
18:00														0			
18:15														0			
18:30														0			
18:45														0			
19:00														0			
19:15														0			
19:30														0			
19:45														0			
20:00														0			
20:15														0			
20:30														0			
20:45														0			
21:00														0			
21:15														0			
21:30														0			
21:45														0			
22:00														0			
22:15														0			
22:30														0			
22:45														0			
23:00														0			
23:15														0			
23:30														0			
23:45														0			
Total	85	16	101	16	74	11	72	10	60	6	49	7	55	6	57	5	630
AM Peak Hr:																	7:15
PK Vol	9	1	24	1	8	3	11	0	13	1	4	0	6	0	2	1	84
MID Peak Hr:																	12:00
PK Vol	15	4	16	2	12	2	16	2	11	1	13	3	20	2	13	0	132
PM Peak Hr:																	16:45
PK Vol	17	4	24	3	21	3	15	4	12	1	10	2	9	0	12	0	137

Intersection ID: 1805130
Count Date: 11/29/2018

N 7TH ST & E INDIAN SCHOOL RD

From North (SB) From East (WB) From South (NB) From West (EB) INTSEC
N 7TH ST E INDIAN SCHOOL RD N 7TH ST E INDIAN SCHOOL RD

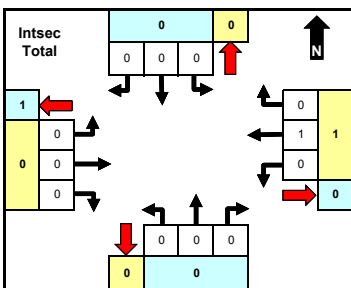
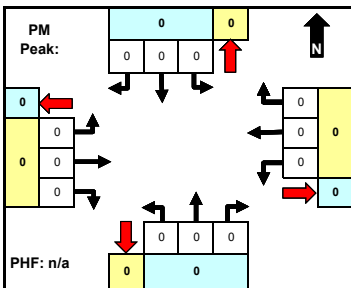
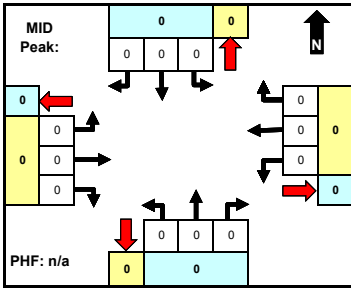
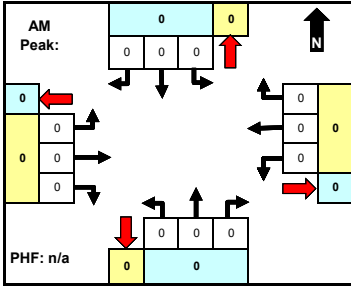

	North		East		South		West		Total
	App	Dep	App	Dep	App	Dep	App	Dep	
AM	0	0	0	0	0	0	0	0	0
MID	0	0	0	0	0	0	0	0	0
PM	0	0	0	0	0	0	0	0	0
Total	0	0	1	0	0	0	0	1	1

Comments

Unless shown otherwise, MID period defined as 10:00 AM - 2:00 PM. Peaks defined based on total intersection volume for all vehicle types.

Time	From North (SB)				From East (WB)				From South (NB)				From West (EB)				INTSEC
	LT	Thru	RT	U	LT	Thru	RT	U	LT	Thru	RT	U	LT	Thru	RT	U	TOTAL
0:00																	0
0:15																	0
0:30																	0
0:45																	0
1:00																	0
1:15																	0
1:30																	0
1:45																	0
2:00																	0
2:15																	0
2:30																	0
2:45																	0
3:00																	0
3:15																	0
3:30																	0
3:45																	0
4:00																	0
4:15																	0
4:30																	0
4:45																	0
5:00																	0
5:15																	0
5:30																	0
5:45																	0
6:00																	0
6:15																	0
6:30	0	0	0	0	0	0	0	0	0	0	0	0	0	0	0	0	0
6:45	0	0	0	0	0	0	0	0	0	0	0	0	0	0	0	0	0
7:00	0	0	0	0	0	0	0	0	0	0	0	0	0	0	0	0	0
7:15	0	0	0	0	0	0	0	0	0	0	0	0	0	0	0	0	0
7:30	0	0	0	0	0	0	0	0	0	0	0	0	0	0	0	0	0
7:45	0	0	0	0	0	0	0	0	0	0	0	0	0	0	0	0	0
8:00	0	0	0	0	0	0	0	0	0	0	0	0	0	0	0	0	0
8:15	0	0	0	0	0	0	0	0	0	0	0	0	0	0	0	0	0
8:30																	0
8:45																	0
9:00																	0
9:15																	0
9:30																	0
9:45																	0
10:00																	0
10:15																	0
10:30																	0
10:45																	0
11:00	0	0	0	0	0	0	0	0	0	0	0	0	0	0	0	0	0
11:15	0	0	0	0	0	1	0	0	0	0	0	0	0	0	0	0	1
11:30	0	0	0	0	0	0	0	0	0	0	0	0	0	0	0	0	0
11:45	0	0	0	0	0	0	0	0	0	0	0	0	0	0	0	0	0
12:00	0	0	0	0	0	0	0	0	0	0	0	0	0	0	0	0	0
12:15	0	0	0	0	0	0	0	0	0	0	0	0	0	0	0	0	0
12:30	0	0	0	0	0	0	0	0	0	0	0	0	0	0	0	0	0
12:45	0	0	0	0	0	0	0	0	0	0	0	0	0	0	0	0	0
13:00																	0
13:15																	0
13:30																	0
13:45																	0
14:00																	0
14:15																	0
14:30																	0
14:45																	0
15:00																	0
15:15																	0
15:30																	0
15:45																	0
16:00	0	0	0	0	0	0	0	0	0	0	0	0	0	0	0	0	0
16:15	0	0	0	0	0	0	0	0	0	0	0	0	0	0	0	0	0
16:30	0	0	0	0	0	0	0	0	0	0	0	0	0	0	0	0	0
16:45	0	0	0	0	0	0	0	0	0	0	0	0	0	0	0	0	0
17:00	0	0	0	0	0	0	0	0	0	0	0	0	0	0	0	0	0
17:15	0	0	0	0	0	0	0	0	0	0	0	0	0	0	0	0	0
17:30	0	0	0	0	0	0	0	0	0	0	0	0	0	0	0	0	0
17:45	0	0	0	0	0	0	0	0	0	0	0	0	0	0	0	0	0
18:00	0	0	0	0	0	0	0	0	0	0	0	0	0	0	0	0	0
18:15																	0
18:30																	0
18:45																	0
19:00																	0
19:15																	0
19:30																	0
19:45																	0
20:00																	0
20:15																	0
20:30																	0
20:45																	0
21:00																	0
21:15																	0
21:30																	0
21:45																	0
22:00																	0
22:15																	0
22:30																	0
22:45																	0
23:00																	0
23:15																	0
23:30																	0
23:45																	0
Total	0	0	0	0	0	0	1	0	0	0	0	0	0	0	0	0	1
AM Peak Hr:																	7:15
Pk Vol	0	0	0	0	0	0	0	0	0	0	0	0	0	0	0	0	0
PHF	n/a	n/a	n/a	n/a	n/a	n/a	n/a	n/a	n/a	n/a	n/a	n/a	n/a	n/a	n/a	n/a	n/a
MID Peak Hr:																	12:00
Pk Vol	0	0	0	0	0	0	0	0	0	0	0	0	0	0	0	0	0
PHF	n/a	n/a	n/a	n/a	n/a	n/a	n/a	n/a	n/a	n/a	n/a	n/a	n/a	n/a	n/a	n/a	n/a
PM Peak Hr:																	16:45
Pk Vol	0	0	0	0	0	0	0	0	0	0	0	0	0	0	0	0	0
PHF	n/a	n/a	n/a	n/a	n/a	n/a	n/a	n/a	n/a	n/a	n/a	n/a	n/a	n/a	n/a	n/a	n/a

Intersection ID: 1805160
Count Date: 11/29/2018

N 7TH ST & VA MED/ GLENROSA

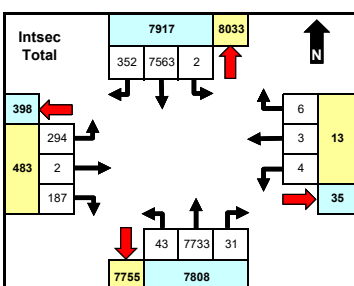
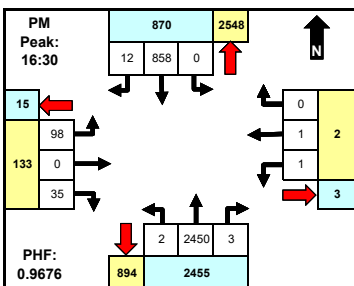
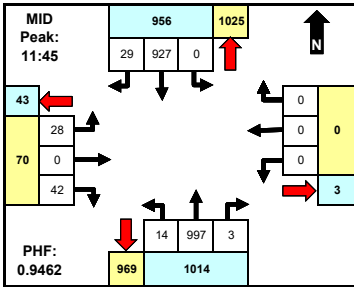
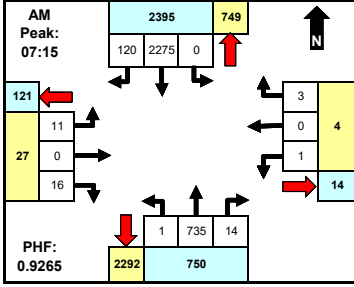

	North		East		South		West		Total
	App	Dep	App	Dep	App	Dep	App	Dep	
AM	2395	749	4	14	750	2292	27	121	3176
MID	956	1025	0	3	1014	969	70	43	2040
PM	870	2548	2	3	2455	894	133	15	3460
Total	7917	8033	13	35	7808	7755	483	398	16221

Comments
Unless shown otherwise, MID period defined as 10:00 AM - 2:00 PM. Peaks defined based on total intersection volume for all vehicle types.

Time	From North (SB)				From East (WB)				From South (NB)				From West (EB)				INTSEC	TOTAL
	N 7TH ST				VA MED/ GLENROSA				N 7TH ST				VA MED/ GLENROSA					
	LT	Thru	RT	U	LT	Thru	RT	U	LT	Thru	RT	U	LT	Thru	RT	U		
0:00																	0	
0:15																	0	
0:30																	0	
0:45																	0	
1:00																	0	
1:15																	0	
1:30																	0	
1:45																	0	
2:00																	0	
2:15																	0	
2:30																	0	
2:45																	0	
3:00																	0	
3:15																	0	
3:30																	0	
3:45																	0	
4:00																	0	
4:15																	0	
4:30																	0	
4:45																	0	
5:00																	0	
5:15																	0	
5:30																	0	
5:45																	0	
6:00																	0	
6:15																	0	
6:30	1	345	51	0	0	0	1	1	0	2	90	1	0	5	0	6	503	
6:45	0	438	55	0	0	0	0	0	0	5	96	0	0	5	0	4	603	
7:00	0	533	30	0	0	1	1	0	0	4	130	1	0	4	0	4	708	
7:15	0	537	30	0	0	0	0	1	0	0	161	3	0	1	0	3	736	
7:30	0	572	30	0	1	0	0	0	0	0	186	4	0	4	0	4	801	
7:45	0	553	29	0	0	0	2	0	0	1	186	4	0	2	0	5	782	
8:00	0	613	31	0	0	0	0	0	0	0	202	3	0	4	0	4	857	
8:15	0	464	25	0	0	0	0	0	0	0	187	2	0	4	1	4	687	
8:30																	0	
8:45																	0	
9:00																	0	
9:15																	0	
9:30																	0	
9:45																	0	
10:00																	0	
10:15																	0	
10:30																	0	
10:45																	0	
11:00	0	190	4	0	0	0	0	0	0	5	224	0	0	8	0	13	444	
11:15	0	213	4	0	0	0	0	0	0	2	198	0	0	10	0	13	440	
11:30	0	203	4	0	0	0	1	0	0	4	208	0	1	8	0	5	434	
11:45	0	230	7	0	0	0	0	0	0	4	247	0	0	7	0	10	505	
12:00	0	233	6	0	0	0	0	0	0	3	230	1	0	5	0	12	490	
12:15	0	232	6	0	0	0	0	0	0	4	274	1	0	10	0	12	539	
12:30	0	232	10	0	0	0	0	0	0	3	246	1	0	6	0	8	506	
12:45	0	237	6	0	1	0	0	0	0	2	211	2	0	5	0	7	471	
13:00																	0	
13:15																	0	
13:30																	0	
13:45																	0	
14:00																	0	
14:15																	0	
14:30																	0	
14:45																	0	
15:00																	0	
15:15																	0	
15:30																	0	
15:45																	0	
16:00	1	207	3	0	0	0	0	0	0	0	515	3	0	55	1	10	795	
16:15	0	193	4	0	0	0	0	0	0	1	570	1	0	31	0	17	817	
16:30	0	195	4	0	0	1	0	0	0	1	612	2	0	47	0	12	874	
16:45	0	216	4	0	0	0	0	0	0	1	602	0	0	15	0	11	849	
17:00	0	219	1	0	1	0	0	0	0	0	594	1	0	23	0	4	843	
17:15	0	228	3	0	0	0	0	0	0	0	642	0	0	13	0	8	894	
17:30	0	222	4	0	0	0	0	0	0	0	600	0	0	10	0	6	842	
17:45	0	258	1	0	1	0	0	0	0	1	522	1	0	12	0	5	801	
18:00																	0	
18:15																	0	
18:30																	0	
18:45																	0	
19:00																	0	
19:15																	0	
19:30																	0	
19:45																	0	
20:00																	0	
20:15																	0	
20:30																	0	
20:45																	0	
21:00																	0	
21:15																	0	
21:30																	0	
21:45																	0	
22:00																	0	
22:15																	0	
22:30																	0	
22:45																	0	
23:00																	0	
23:15																	0	
23:30																	0	
23:45																	0	
Total	2	7563	352	0	4	3	6	0	43	7733	31	1	294	2	187	0	16221	
AM Peak Hr:																	7:15	
PK Vol	0	2275	120	0	1	0	3	0	1	735	14	0	11	0	16	0	3176	
PHF	n/a	0.928	0.968	n/a	0.250	n/a	0.375	n/a	0.250	0.910	0.875	n/a	0.688	n/a	0.800	n/a	0.926	
MID Peak Hr:																	11:45	
PK Vol	0	927	29	0	0	0	0	0	14	997	3	0	28	0	42	0	2040	
PHF	n/a	0.995	0.725	n/a	n/a	n/a	n/a	n/a	0.875	0.910	0.750	n/a	0.700	n/a	0.875	n/a	0.945	
PM Peak Hr:																	16:30	
PK Vol	0	858	12	0	1	1	0	0	2	2460	3	0	98	0	35	0	3460	
PHF	n/a	0.941	0.750	n/a	0.250	0.250	n/a	n/a	0.500	0.954	0.375	n/a	0.521	n/a	0.729	n/a	0.968	

Intersection ID: 1805160
Count Date: 11/29/2018

N 7TH ST & VA MED/ GLENROSA

From North (SB) From East (WB) From South (NB) From West (EB)
N 7TH ST VA MED/ GLENROSA N 7TH ST VA MED/ GLENROSA INTSEC

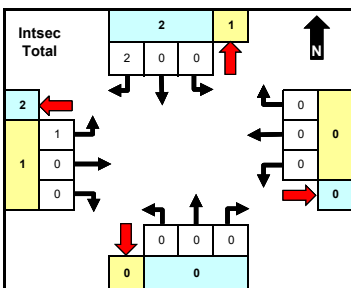
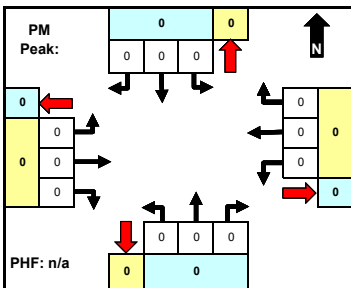
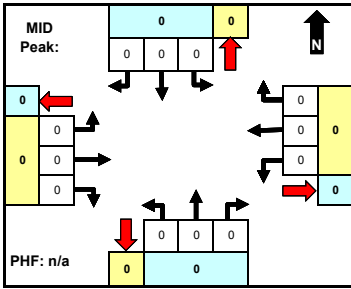
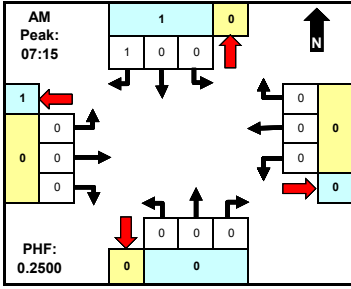

	North		East		South		West		Total
	App	Dep	App	Dep	App	Dep	App	Dep	
AM	1	0	0	0	0	0	0	0	1
MID	0	0	0	0	0	0	0	0	0
PM	0	0	0	0	0	0	0	0	0
Total	2	1	0	0	0	0	1	2	3

Comments
Unless shown otherwise, MID period defined as 10:00 AM - 2:00 PM. Peaks defined based on total intersection volume for all vehicle types.

Time	LT	Thru	RT	U	LT	Thru	RT	U	LT	Thru	RT	U	LT	Thru	RT	U	TOTAL
0:00																	0
0:15																	0
0:30																	0
0:45																	0
1:00																	0
1:15																	0
1:30																	0
1:45																	0
2:00																	0
2:15																	0
2:30																	0
2:45																	0
3:00																	0
3:15																	0
3:30																	0
3:45																	0
4:00																	0
4:15																	0
4:30																	0
4:45																	0
5:00																	0
5:15																	0
5:30																	0
5:45																	0
6:00																	0
6:15																	0
6:30	0	0	0	0	0	0	0	0	0	0	0	0	0	0	0	0	0
6:45	0	0	0	0	0	0	0	0	0	0	0	0	0	0	0	0	0
7:00	0	0	0	1	0	0	0	0	0	0	0	0	0	0	0	0	1
7:15	0	0	0	0	0	0	0	0	0	0	0	0	0	0	0	0	0
7:30	0	0	0	1	0	0	0	0	0	0	0	0	0	0	0	0	1
7:45	0	0	0	0	0	0	0	0	0	0	0	0	0	0	0	0	0
8:00	0	0	0	0	0	0	0	0	0	0	0	0	0	0	0	0	0
8:15	0	0	0	0	0	0	0	0	0	0	0	0	0	0	0	0	0
8:30																	0
8:45																	0
9:00																	0
9:15																	0
9:30																	0
9:45																	0
10:00																	0
10:15																	0
10:30																	0
10:45																	0
11:00	0	0	0	0	0	0	0	0	0	0	0	0	0	0	0	0	0
11:15	0	0	0	0	0	0	0	0	0	0	0	0	0	0	0	0	0
11:30	0	0	0	0	0	0	0	0	0	0	0	0	0	0	0	0	0
11:45	0	0	0	0	0	0	0	0	0	0	0	0	0	0	0	0	0
12:00	0	0	0	0	0	0	0	0	0	0	0	0	0	0	0	0	0
12:15	0	0	0	0	0	0	0	0	0	0	0	0	0	0	0	0	0
12:30	0	0	0	0	0	0	0	0	0	0	0	0	0	0	0	0	0
12:45	0	0	0	0	0	0	0	0	0	0	0	0	0	0	0	0	0
13:00																	0
13:15																	0
13:30																	0
13:45																	0
14:00																	0
14:15																	0
14:30																	0
14:45																	0
15:00																	0
15:15																	0
15:30																	0
15:45																	0
16:00	0	0	0	0	0	0	0	0	0	0	0	0	0	0	0	0	0
16:15	0	0	0	0	0	0	0	0	0	0	0	0	0	0	1	0	1
16:30	0	0	0	0	0	0	0	0	0	0	0	0	0	0	0	0	0
16:45	0	0	0	0	0	0	0	0	0	0	0	0	0	0	0	0	0
17:00	0	0	0	0	0	0	0	0	0	0	0	0	0	0	0	0	0
17:15	0	0	0	0	0	0	0	0	0	0	0	0	0	0	0	0	0
17:30	0	0	0	0	0	0	0	0	0	0	0	0	0	0	0	0	0
17:45	0	0	0	0	0	0	0	0	0	0	0	0	0	0	0	0	0
18:00	0	0	0	0	0	0	0	0	0	0	0	0	0	0	0	0	0
18:15																	0
18:30																	0
18:45																	0
19:00																	0
19:15																	0
19:30																	0
19:45																	0
20:00																	0
20:15																	0
20:30																	0
20:45																	0
21:00																	0
21:15																	0
21:30																	0
21:45																	0
22:00																	0
22:15																	0
22:30																	0
22:45																	0
23:00																	0
23:15																	0
23:30																	0
23:45																	0
Total	0	0	2	0	0	0	0	0	0	0	0	0	0	1	0	0	3
AM Peak Hr:																	7:15
Pk Vol	0	0	1	0	0	0	0	0	0	0	0	0	0	0	0	0	1
PHF	n/a	n/a	0.250	n/a	n/a	n/a	n/a	n/a	n/a	n/a	n/a	n/a	n/a	n/a	n/a	n/a	0.250
MID Peak Hr:																	11:45
Pk Vol	0	0	0	0	0	0	0	0	0	0	0	0	0	0	0	0	0
PHF	n/a	n/a	n/a	n/a	n/a	n/a	n/a	n/a	n/a	n/a	n/a	n/a	n/a	n/a	n/a	n/a	n/a
PM Peak Hr:																	16:30
Pk Vol	0	0	0	0	0	0	0	0	0	0	0	0	0	0	0	0	0
PHF	n/a	n/a	n/a	n/a	n/a	n/a	n/a	n/a	n/a	n/a	n/a	n/a	n/a	n/a	n/a	n/a	n/a



Intersection ID: 1805160
Count Date: 11/29/2018

N 7TH ST & VA MED/ GLENROSA

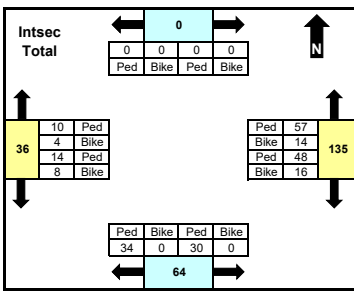
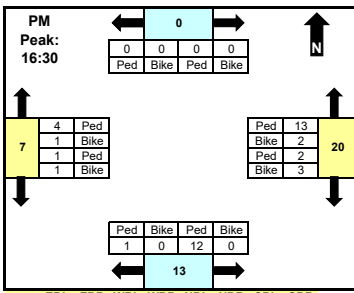
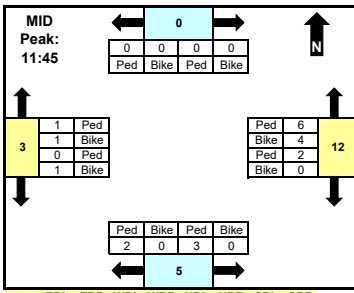
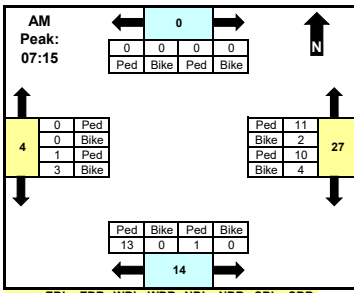

	North		East		South		West		Total
	CW	CCW	CW	CCW	CW	CCW	CW	CCW	
AM	0	0	14	13	13	1	0	4	45
MID	0	0	2	10	2	3	2	1	20
PM	0	0	5	15	1	12	5	2	40
Total	0	0	64	71	34	30	14	22	235

CW = Clockwise
CCW = Counter-clockwise

Comments

Unless shown otherwise, MID period defined as 10:00 AM - 2:00 PM. Crosswalk peaks defined based on total intersection volume for all vehicle types.

Time	North Leg		East Leg		South Leg		West Leg		INTSEC	TOTAL	
	CW	CCW	CW	CCW	CW	CCW	CW	CCW			
0:00										0	
0:15										0	
0:30										0	
0:45										0	
1:00										0	
1:15										0	
1:30										0	
1:45										0	
2:00										0	
2:15										0	
2:30										0	
2:45										0	
3:00										0	
3:15										0	
3:30										0	
3:45										0	
4:00										0	
4:15										0	
4:30										0	
4:45										0	
5:00										0	
5:15										0	
5:30										0	
5:45										0	
6:00										0	
6:15										0	
6:30	0	0	0	0	1	1	3	0	1	7	
6:45	0	0	0	0	2	2	2	0	0	7	
7:00	0	0	0	0	2	0	0	0	3	9	
7:15	0	0	0	0	6	0	2	1	4	16	
7:30	0	0	0	0	1	5	0	2	0	11	
7:45	0	0	0	0	3	3	3	1	6	17	
8:00	0	0	0	0	1	0	1	0	0	3	
8:15	0	0	0	0	3	0	3	0	4	11	
8:30										0	
8:45										0	
9:00										0	
9:15										0	
9:30										0	
9:45										0	
10:00										0	
10:15										0	
10:30										0	
10:45										0	
11:00	0	0	0	0	2	3	1	1	0	14	
11:15	0	0	0	0	4	1	3	0	2	14	
11:30	0	0	0	0	1	0	1	0	2	5	
11:45	0	0	0	0	0	2	0	0	1	3	
12:00	0	0	0	0	0	0	3	0	0	3	
12:15	0	0	0	0	1	0	1	0	0	4	
12:30	0	0	0	0	1	0	3	1	2	10	
12:45	0	0	0	0	3	0	1	0	0	7	
13:00										0	
13:15										0	
13:30										0	
13:45										0	
14:00										0	
14:15										0	
14:30										0	
14:45										0	
15:00										0	
15:15										0	
15:30										0	
15:45										0	
16:00	0	0	0	0	3	1	1	2	0	14	
16:15	0	0	0	0	1	5	1	0	0	13	
16:30	0	0	0	0	2	5	1	0	3	13	
16:45	0	0	0	0	1	0	5	0	1	14	
17:00	0	0	0	0	1	1	1	0	0	7	
17:15	0	0	0	0	0	2	1	0	0	6	
17:30	0	0	0	0	3	0	3	2	2	11	
17:45	0	0	0	0	10	0	4	0	2	18	
18:00										0	
18:15										0	
18:30										0	
18:45										0	
19:00										0	
19:15										0	
19:30										0	
19:45										0	
20:00										0	
20:15										0	
20:30										0	
20:45										0	
21:00										0	
21:15										0	
21:30										0	
21:45										0	
22:00										0	
22:15										0	
22:30										0	
22:45										0	
23:00										0	
23:15										0	
23:30										0	
23:45										0	
Total	0	0	0	0	48	16	57	14	34	0	235
AM Peak Hr:											7:15
PK Vol	0	0	0	0	10	4	11	2	13	0	45
MID Peak Hr:											11:45
PK Vol	0	0	0	0	2	0	6	4	2	0	20
PM Peak Hr:											16:30
PK Vol	0	0	0	0	2	3	13	2	1	0	40

Intersection ID: 1805158
Count Date: 11/29/2018

N 7TH ST & At CAMPBELL AVE (Central High School)

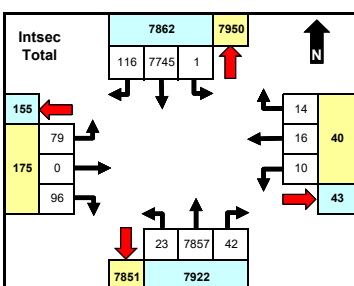
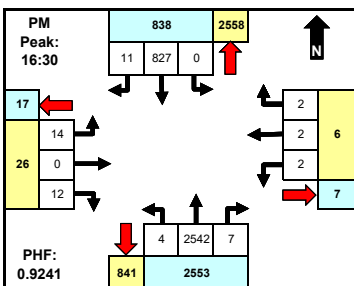
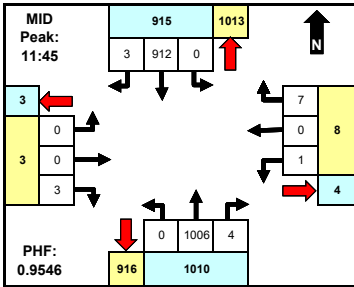
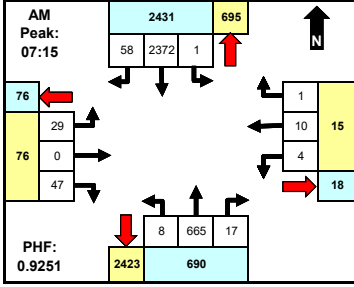

	North		East		South		West		Total
	App	Dep	App	Dep	App	Dep	App	Dep	
AM	2431	695	15	18	690	2423	76	76	3212
MID	915	1013	8	4	1010	916	3	3	1936
PM	838	2558	6	7	2553	841	26	17	3423
Total	7862	7950	40	43	7922	7851	175	155	15999

Comments
Unless shown otherwise, MID period defined as 10:00 AM - 2:00 PM. Peaks defined based on total intersection volume for all vehicle types.

Time	From North (SB)				From East (WB)				From South (NB)				From West (EB)				TOTAL
	N 7TH ST				At CAMPBELL AVE (Con N 7TH ST)				At CAMPBELL AVE (Con				INTSEC				
	LT	Thru	RT	U	LT	Thru	RT	U	LT	Thru	RT	U	LT	Thru	RT	U	
0:00																	0
0:15																	0
0:30																	0
0:45																	0
1:00																	0
1:15																	0
1:30																	0
1:45																	0
2:00																	0
2:15																	0
2:30																	0
2:45																	0
3:00																	0
3:15																	0
3:30																	0
3:45																	0
4:00																	0
4:15																	0
4:30																	0
4:45																	0
5:00																	0
5:15																	0
5:30																	0
5:45																	0
6:00																	0
6:15																	0
6:30	0	413	6	0	0	0	0	0	1	88	0	0	0	0	1	0	509
6:45	0	496	7	0	0	1	0	0	0	98	1	0	3	0	6	0	612
7:00	0	580	9	0	0	0	0	0	2	112	0	0	2	0	4	0	709
7:15	0	558	11	0	2	2	0	0	1	146	4	0	4	0	10	0	738
7:30	0	597	18	0	1	1	0	0	1	165	3	0	6	0	12	0	804
7:45	0	582	20	0	0	6	1	0	4	168	7	0	8	0	6	0	802
8:00	1	635	9	0	1	1	0	0	2	186	3	0	11	0	19	0	868
8:15	0	492	5	0	0	0	0	0	2	201	1	0	1	0	6	0	708
8:30																	0
8:45																	0
9:00																	0
9:15																	0
9:30																	0
9:45																	0
10:00																	0
10:15																	0
10:30																	0
10:45																	0
11:00	0	181	1	0	0	0	0	0	0	230	1	0	1	0	0	0	414
11:15	0	205	0	0	0	0	0	0	2	205	0	0	0	0	0	0	412
11:30	0	206	0	0	0	0	1	0	0	216	2	0	1	0	1	0	427
11:45	0	224	1	0	0	0	1	0	0	241	1	0	0	0	0	0	468
12:00	0	227	0	0	0	0	1	0	0	249	1	0	0	0	2	0	480
12:15	0	226	1	0	1	0	1	0	0	278	0	0	0	0	0	0	507
12:30	0	235	1	0	0	0	4	0	0	238	2	0	0	0	1	0	481
12:45	0	230	0	0	0	0	0	0	0	219	2	0	0	0	0	0	451
13:00																	0
13:15																	0
13:30																	0
13:45																	0
14:00																	0
14:15																	0
14:30																	0
14:45																	0
15:00																	0
15:15																	0
15:30																	0
15:45																	0
16:00	0	197	9	0	1	1	0	0	1	578	2	0	6	0	3	0	798
16:15	0	186	3	0	2	1	0	0	1	596	2	0	6	0	2	0	799
16:30	0	190	3	0	0	2	0	0	1	644	1	0	6	0	4	0	851
16:45	0	201	2	0	1	0	1	0	2	589	2	0	3	0	5	0	806
17:00	0	211	4	0	0	0	1	0	1	617	3	0	2	0	1	0	840
17:15	0	225	2	0	1	0	0	0	0	692	1	0	3	0	2	0	926
17:30	0	206	4	0	0	0	0	0	0	580	0	0	0	0	5	0	798
17:45	0	242	0	0	0	1	3	0	2	521	3	0	13	0	6	0	791
18:00																	0
18:15																	0
18:30																	0
18:45																	0
19:00																	0
19:15																	0
19:30																	0
19:45																	0
20:00																	0
20:15																	0
20:30																	0
20:45																	0
21:00																	0
21:15																	0
21:30																	0
21:45																	0
22:00																	0
22:15																	0
22:30																	0
22:45																	0
23:00																	0
23:15																	0
23:30																	0
23:45																	0
Total	1	7745	116	0	10	16	14	0	23	7857	42	0	79	0	96	0	15999
AM Peak Hr:																	7:15
PK Vol	1	2372	58	0	4	10	1	0	8	665	17	0	29	0	47	0	3212
PHF	0.250	0.334	0.725	n/a	0.500	0.417	0.250	n/a	0.500	0.894	0.607	n/a	0.659	n/a	0.618	n/a	0.925
MID Peak Hr:																	11:45
PK Vol	0	912	31	0	1	0	7	0	0	1066	4	0	0	0	3	0	1936
PHF	n/a	0.970	0.750	n/a	0.250	n/a	0.438	n/a	n/a	0.905	0.500	n/a	n/a	n/a	0.375	n/a	0.955
PM Peak Hr:																	16:30
PK Vol	0	827	11	0	2	2	2	0									

Intersection ID: 1805158
Count Date: 11/29/2018

N 7TH ST & At CAMPBELL AVE (Central High School)

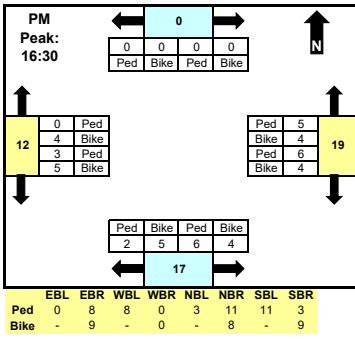
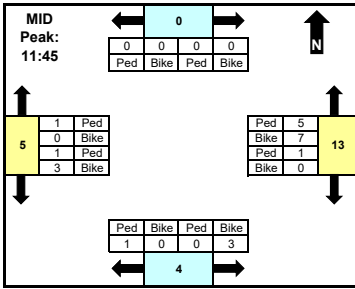
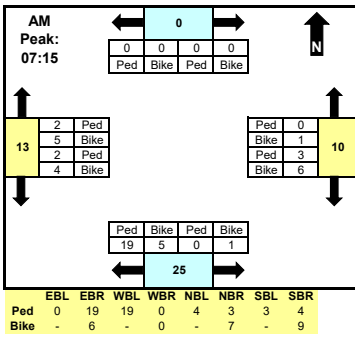

	North		East		South		West		Total
	CW	CCW	CW	CCW	CW	CCW	CW	CCW	
AM	0	0	9	1	24	1	7	6	48
MID	0	0	1	12	1	3	1	4	22
PM	0	0	10	9	7	10	4	8	48
Total	0	0	43	53	47	36	23	39	241

CW = Clockwise
CCW = Counter-clockwise

Comments
Unless shown otherwise, MID period defined as 10:00 AM - 2:00 PM. Crosswalk peaks defined based on total intersection volume for all vehicle types.

Time	North Leg		East Leg		South Leg		West Leg		INTSEC	TOTAL							
	CW	CCW	CW	CCW	CW	CCW	CW	CCW									
0:00										0							
0:15										0							
0:30										0							
0:45										0							
1:00										0							
1:15										0							
1:30										0							
1:45										0							
2:00										0							
2:15										0							
2:30										0							
2:45										0							
3:00										0							
3:15										0							
3:30										0							
3:45										0							
4:00										0							
4:15										0							
4:30										0							
4:45										0							
5:00										0							
5:15										0							
5:30										0							
5:45										0							
6:00										0							
6:15										0							
6:30	0	0	0	0	0	3	2	1	0	2	11						
6:45	0	0	0	0	0	4	1	0	0	4	11						
7:00	0	0	0	0	2	2	0	2	1	1	13						
7:15	0	0	0	0	0	1	0	1	1	0	7						
7:30	0	0	0	0	1	4	0	0	8	3	21						
7:45	0	0	0	0	2	0	0	0	9	1	15						
8:00	0	0	0	0	0	1	0	0	2	0	5						
8:15	0	0	0	0	0	1	0	0	2	0	10						
8:30						3	0	2	0	4	0						
8:45						0	0	0	0	0	0						
9:00						0	0	0	0	0	0						
9:15						0	0	0	0	0	0						
9:30						0	0	0	0	0	0						
9:45						0	0	0	0	0	0						
10:00						0	0	0	0	0	0						
10:15						0	0	0	0	0	0						
10:30						0	0	0	0	0	0						
10:45						0	0	0	0	0	0						
11:00	0	0	0	0	0	1	4	2	2	0	11						
11:15	0	0	0	0	0	1	1	0	0	0	6						
11:30	0	0	0	0	0	0	1	0	0	0	2						
11:45	0	0	0	0	0	0	1	0	0	0	2						
12:00	0	0	0	0	0	0	6	1	0	0	12						
12:15	0	0	0	0	1	0	0	1	0	0	3						
12:30	0	0	0	0	0	0	4	0	0	0	5						
12:45	0	0	0	0	1	0	1	0	1	1	9						
13:00						0	0	0	0	0	0						
13:15						0	0	0	0	0	0						
13:30						0	0	0	0	0	0						
13:45						0	0	0	0	0	0						
14:00						0	0	0	0	0	0						
14:15						0	0	0	0	0	0						
14:30						0	0	0	0	0	0						
14:45						0	0	0	0	0	0						
15:00						0	0	0	0	0	0						
15:15						0	0	0	0	0	0						
15:30						0	0	0	0	0	0						
15:45	0	0	0	0	2	0	1	2	1	0	15						
16:00	0	0	0	0	1	0	3	0	1	0	10						
16:15	0	0	0	0	1	1	4	0	1	2	15						
16:30	0	0	0	0	2	1	0	2	0	1	15						
16:45	0	0	0	0	1	1	1	1	3	0	7						
17:00	0	0	0	0	1	1	1	0	2	0	11						
17:15	0	0	0	0	2	1	0	2	1	1	11						
17:30	0	0	0	0	3	0	3	0	1	2	9						
17:45	0	0	0	0	2	0	4	1	0	6	16						
18:00						0	0	0	0	0	0						
18:15						0	0	0	0	0	0						
18:30						0	0	0	0	0	0						
18:45						0	0	0	0	0	0						
19:00						0	0	0	0	0	0						
19:15						0	0	0	0	0	0						
19:30						0	0	0	0	0	0						
19:45						0	0	0	0	0	0						
20:00						0	0	0	0	0	0						
20:15						0	0	0	0	0	0						
20:30						0	0	0	0	0	0						
20:45						0	0	0	0	0	0						
21:00						0	0	0	0	0	0						
21:15						0	0	0	0	0	0						
21:30						0	0	0	0	0	0						
21:45						0	0	0	0	0	0						
22:00						0	0	0	0	0	0						
22:15						0	0	0	0	0	0						
22:30						0	0	0	0	0	0						
22:45						0	0	0	0	0	0						
23:00						0	0	0	0	0	0						
23:15						0	0	0	0	0	0						
23:30						0	0	0	0	0	0						
23:45						0	0	0	0	0	0						
Total	0	0	0	0	25	18	30	23	34	13	22	14	9	14	15	24	241
AM Peak Hr:																	7:15
PK Vol	0	0	0	0	3	6	0	1	19	5	0	1	2	5	2	4	48
MID Peak Hr:																	11:45
PK Vol	0	0	0	0	1	0	5	7	1	0	0	3	1	0	1	3	22
PM Peak Hr:																	16:30
PK Vol	0	0	0	0	6	4	5	4	2	5	6	4	0	4	3	5	48

Intersection ID: 1805158
Count Date: 11/29/2018

N 7TH ST & At CAMPBELL AVE (Central High School)

From North (SB) From East (WB) From South (NB) From West (EB)
N 7TH ST At CAMPBELL AVE (Con N 7TH ST) At CAMPBELL AVE (Con

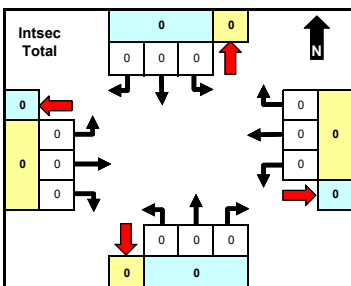
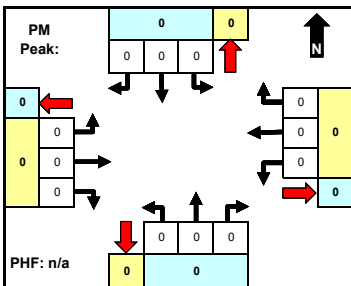
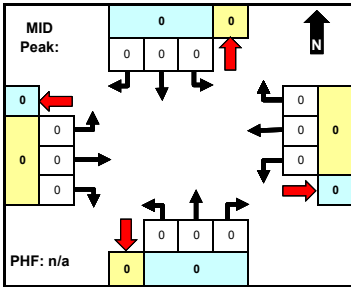
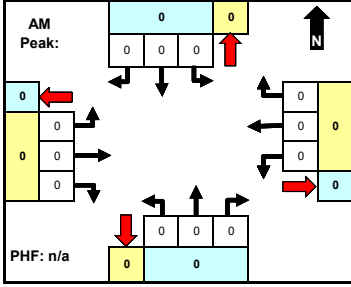

	North		East		South		West		Total
	App	Dep	App	Dep	App	Dep	App	Dep	
AM	0	0	0	0	0	0	0	0	0
MID	0	0	0	0	0	0	0	0	0
PM	0	0	0	0	0	0	0	0	0
Total	0	0	0	0	0	0	0	0	0

Comments

Unless shown otherwise, MID period defined as 10:00 AM - 2:00 PM. Peaks defined based on total intersection volume for all vehicle types.

Time	From North (SB)				From East (WB)				From South (NB)				From West (EB)				INTSEC	TOTAL
	LT	Thru	RT	U	LT	Thru	RT	U	LT	Thru	RT	U	LT	Thru	RT	U		
0:00																	0	
0:15																	0	
0:30																	0	
0:45																	0	
1:00																	0	
1:15																	0	
1:30																	0	
1:45																	0	
2:00																	0	
2:15																	0	
2:30																	0	
2:45																	0	
3:00																	0	
3:15																	0	
3:30																	0	
3:45																	0	
4:00																	0	
4:15																	0	
4:30																	0	
4:45																	0	
5:00																	0	
5:15																	0	
5:30																	0	
5:45																	0	
6:00																	0	
6:15																	0	
6:30	0	0	0	0	0	0	0	0	0	0	0	0	0	0	0	0		
6:45	0	0	0	0	0	0	0	0	0	0	0	0	0	0	0	0		
7:00	0	0	0	0	0	0	0	0	0	0	0	0	0	0	0	0		
7:15	0	0	0	0	0	0	0	0	0	0	0	0	0	0	0	0		
7:30	0	0	0	0	0	0	0	0	0	0	0	0	0	0	0	0		
7:45	0	0	0	0	0	0	0	0	0	0	0	0	0	0	0	0		
8:00	0	0	0	0	0	0	0	0	0	0	0	0	0	0	0	0		
8:15	0	0	0	0	0	0	0	0	0	0	0	0	0	0	0	0		
8:30																	0	
8:45																	0	
9:00																	0	
9:15																	0	
9:30																	0	
9:45																	0	
10:00																	0	
10:15																	0	
10:30																	0	
10:45																	0	
11:00	0	0	0	0	0	0	0	0	0	0	0	0	0	0	0	0		
11:15	0	0	0	0	0	0	0	0	0	0	0	0	0	0	0	0		
11:30	0	0	0	0	0	0	0	0	0	0	0	0	0	0	0	0		
11:45	0	0	0	0	0	0	0	0	0	0	0	0	0	0	0	0		
12:00	0	0	0	0	0	0	0	0	0	0	0	0	0	0	0	0		
12:15	0	0	0	0	0	0	0	0	0	0	0	0	0	0	0	0		
12:30	0	0	0	0	0	0	0	0	0	0	0	0	0	0	0	0		
12:45	0	0	0	0	0	0	0	0	0	0	0	0	0	0	0	0		
13:00																	0	
13:15																	0	
13:30																	0	
13:45																	0	
14:00																	0	
14:15																	0	
14:30																	0	
14:45																	0	
15:00																	0	
15:15																	0	
15:30																	0	
15:45																	0	
16:00	0	0	0	0	0	0	0	0	0	0	0	0	0	0	0	0		
16:15	0	0	0	0	0	0	0	0	0	0	0	0	0	0	0	0		
16:30	0	0	0	0	0	0	0	0	0	0	0	0	0	0	0	0		
16:45	0	0	0	0	0	0	0	0	0	0	0	0	0	0	0	0		
17:00	0	0	0	0	0	0	0	0	0	0	0	0	0	0	0	0		
17:15	0	0	0	0	0	0	0	0	0	0	0	0	0	0	0	0		
17:30	0	0	0	0	0	0	0	0	0	0	0	0	0	0	0	0		
17:45	0	0	0	0	0	0	0	0	0	0	0	0	0	0	0	0		
18:00																	0	
18:15																	0	
18:30																	0	
18:45																	0	
19:00																	0	
19:15																	0	
19:30																	0	
19:45																	0	
20:00																	0	
20:15																	0	
20:30																	0	
20:45																	0	
21:00																	0	
21:15																	0	
21:30																	0	
21:45																	0	
22:00																	0	
22:15																	0	
22:30																	0	
22:45																	0	
23:00																	0	
23:15																	0	
23:30																	0	
23:45																	0	
Total	0	0	0	0	0	0	0	0	0	0	0	0	0	0	0	0	0	
AM Peak Hr:	7:15																	
Pk Vol	0	0	0	0	0	0	0	0	0	0	0	0	0	0	0	0	0	
PHF	n/a	n/a	n/a	n/a	n/a	n/a	n/a	n/a	n/a	n/a	n/a	n/a	n/a	n/a	n/a	n/a	n/a	
MID Peak Hr:	11:45																	
Pk Vol	0	0	0	0	0	0	0	0	0	0	0	0	0	0	0	0	0	
PHF	n/a	n/a	n/a	n/a	n/a	n/a	n/a	n/a	n/a	n/a	n/a	n/a	n/a	n/a	n/a	n/a	n/a	
PM Peak Hr:	16:30																	
Pk Vol	0	0	0	0	0	0	0	0	0	0	0	0	0	0	0	0	0	
PHF	n/a	n/a	n/a	n/a	n/a	n/a	n/a	n/a	n/a	n/a	n/a	n/a	n/a	n/a	n/a	n/a	n/a	

Intersection ID: 1805133
Count Date: 11/29/2018

N 7TH ST & E HIGHLAND AVE

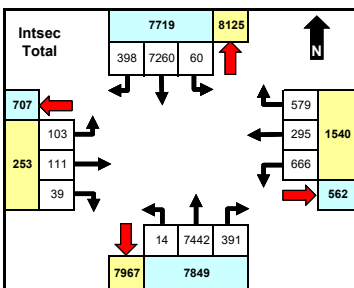
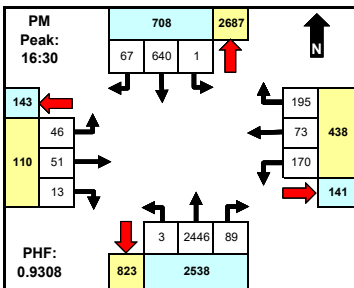
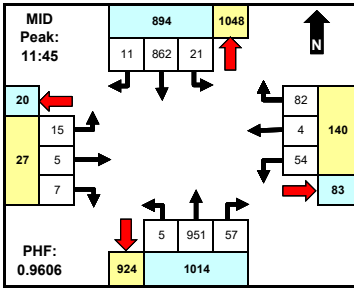
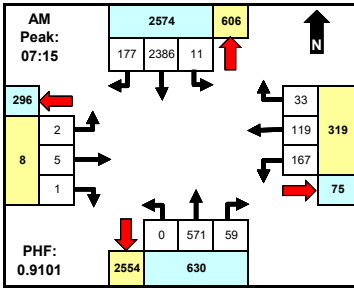

	North		East		South		West		Total
	App	Dep	App	Dep	App	Dep	App	Dep	
AM	2574	606	319	75	630	2554	8	296	3531
MID	894	1048	140	83	1014	924	27	20	2075
PM	708	2687	438	141	2538	823	110	143	3794
Total	7719	8125	1540	562	7849	7967	253	707	17361

Comments

Unless shown otherwise, MID period defined as 10:00 AM - 2:00 PM. Peaks defined based on total intersection volume for all vehicle types.

Time	From North (SB)		From East (WB)		From South (NB)		From West (EB)		INTSEC	TOTAL							
	N 7TH ST		E HIGHLAND AVE		N 7TH ST		E HIGHLAND AVE										
	LT	Thru	RT	U	LT	Thru	RT	U									
0:00										0							
0:15										0							
0:30										0							
0:45										0							
1:00										0							
1:15										0							
1:30										0							
1:45										0							
2:00										0							
2:15										0							
2:30										0							
2:45										0							
3:00										0							
3:15										0							
3:30										0							
3:45										0							
4:00										0							
4:15										0							
4:30										0							
4:45										0							
5:00										0							
5:15										0							
5:30										0							
5:45										0							
6:00										0							
6:15										0							
6:30	1	403	11	0	14	4	3	0	0	72	9	0	0	2	1	0	520
6:45	0	494	15	0	18	11	5	0	0	79	10	0	0	0	0	0	632
7:00	0	572	30	0	24	25	3	0	0	92	7	0	0	0	1	0	754
7:15	1	579	74	0	53	46	5	0	0	118	10	0	0	1	0	0	887
7:30	2	624	78	0	51	50	6	0	0	149	9	0	0	1	0	0	970
7:45	5	565	16	0	37	21	12	0	0	130	17	0	1	2	0	0	806
8:00	3	618	9	0	26	2	10	0	0	174	23	0	1	1	1	0	868
8:15	5	488	5	0	20	2	13	0	0	171	11	0	1	1	0	0	717
8:30																	0
8:45																	0
9:00																	0
9:15																	0
9:30																	0
9:45																	0
10:00																	0
10:15																	0
10:30																	0
10:45																	0
11:00	4	171	2	0	9	1	14	0	0	224	9	1	5	1	0	0	441
11:15	4	188	3	0	14	0	15	0	0	202	6	0	5	0	1	0	438
11:30	5	193	5	0	9	2	14	0	1	204	11	0	3	0	0	0	447
11:45	5	211	4	0	11	2	14	0	0	232	14	1	3	2	2	0	501
12:00	4	210	5	0	16	0	24	0	0	234	8	0	5	1	3	0	510
12:15	6	219	1	0	19	1	25	0	0	250	15	0	3	1	0	0	540
12:30	6	222	1	0	8	1	19	0	5	235	20	0	4	1	2	0	524
12:45	6	222	7	0	9	1	17	0	2	204	10	0	5	2	0	0	485
13:00																	0
13:15																	0
13:30																	0
13:45																	0
14:00																	0
14:15																	0
14:30																	0
14:45																	0
15:00																	0
15:15																	0
15:30																	0
15:45																	0
16:00	2	141	12	0	40	14	38	0	1	470	22	0	5	8	5	0	758
16:15	0	153	13	1	39	8	43	0	0	653	33	0	3	4	0	0	950
16:30	1	140	6	0	39	12	53	0	0	592	20	0	8	10	2	0	883
16:45	0	163	23	0	39	23	38	0	1	637	18	0	7	17	3	0	969
17:00	0	159	21	0	44	24	65	0	1	551	19	0	22	12	5	0	923
17:15	0	178	17	0	48	14	39	0	1	666	32	0	9	12	3	0	1019
17:30	0	147	17	0	43	15	56	0	1	525	25	0	6	20	8	0	863
17:45	0	200	23	0	36	16	48	0	1	578	33	0	7	11	3	0	956
18:00																	0
18:15																	0
18:30																	0
18:45																	0
19:00																	0
19:15																	0
19:30																	0
19:45																	0
20:00																	0
20:15																	0
20:30																	0
20:45																	0
21:00																	0
21:15																	0
21:30																	0
21:45																	0
22:00																	0
22:15																	0
22:30																	0
22:45																	0
23:00																	0
23:15																	0
23:30																	0
23:45																	0
Total	60	7260	398	1	666	295	579	0	14	7442	391	2	403	111	39	0	17361
AM Peak Hr:																	7:15
PK Vol	11	2386	177	0	167	119	33	0	0	571	69	0	2	5	1	0	3531
PHF	0.550	0.956	0.567	n/a	0.788	0.595	0.688	n/a	n/a	0.820	0.641	n/a	0.500	0.625	0.250	n/a	0.910
MID Peak Hr:																	11:45
PK Vol	21	862	11	0	54	4	82	0	5	951	67	1	15	5	7	0	2075
PHF	0.875	0.971	0.550	n/a	0.711	0.500	0.820	n/a	0.250	0.951	0.713	0.250	0.750	0.625	0.583	n/a	0.961
PM Peak Hr:																	16:30
PK Vol	1	640	67	0	170	73	195	0	3	2446	89	0	46	51	13	0	3794
PHF	0.250	0.899	0.728	n/a	0.885	0.760	0.750	n/a	0.750	0.918	0.695	n/a	0.523	0.750	0.650	n/a	0.931

Intersection ID: 1805133
Count Date: 11/29/2018

N 7TH ST & E HIGHLAND AVE

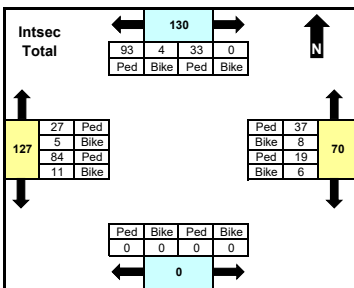
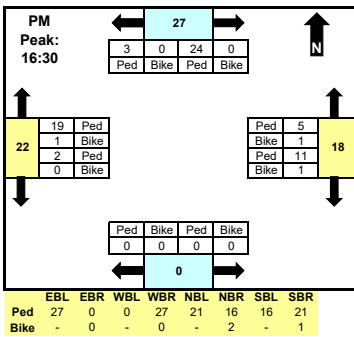
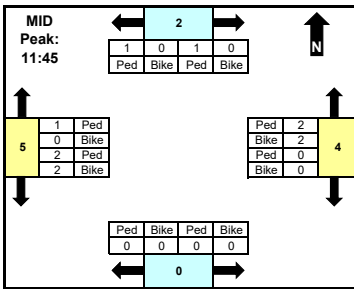
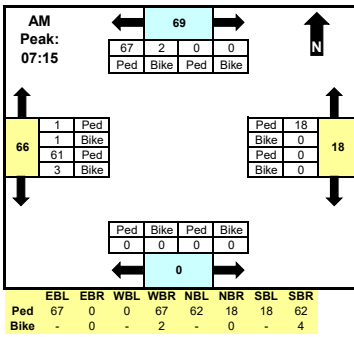

	North		East		South		West		Total
	CW	CCW	CW	CCW	CW	CCW	CW	CCW	
AM	0	69	0	18	0	0	2	64	153
MID	1	1	0	4	0	0	1	4	11
PM	24	3	12	6	0	0	20	2	67
Total	33	97	25	45	0	0	32	95	327

CW = Clockwise
CCW = Counter-clockwise

Comments

Unless shown otherwise, MID period defined as 10:00 AM - 2:00 PM. Crosswalk peaks defined based on total intersection volume for all vehicle types.

Time	North Leg		East Leg		South Leg		West Leg		INTSEC	TOTAL						
	CW	CCW	CW	CCW	CW	CCW	CW	CCW								
0:00										0						
0:15										0						
0:30										0						
0:45										0						
1:00										0						
1:15										0						
1:30										0						
1:45										0						
2:00										0						
2:15										0						
2:30										0						
2:45										0						
3:00										0						
3:15										0						
3:30										0						
3:45										0						
4:00										0						
4:15										0						
4:30										0						
4:45										0						
5:00										0						
5:15										0						
5:30										0						
5:45										0						
6:00										0						
6:15										0						
6:30	0	0	1	0	0	1	0	0	0	1	3					
6:45	0	0	5	0	0	1	2	0	0	0	5	14				
7:00	0	0	4	0	1	1	3	2	0	0	1	17				
7:15	0	0	15	0	0	0	10	0	0	0	0	33				
7:30	0	0	39	0	0	0	8	0	0	0	41	89				
7:45	0	0	13	2	0	0	0	0	0	1	12	28				
8:00	0	0	0	0	0	0	0	0	0	1	0	1				
8:15	0	0	1	0	1	0	0	0	0	0	0	2				
8:30												0				
8:45												0				
9:00												0				
9:15												0				
9:30												0				
9:45												0				
10:00												0				
10:15												0				
10:30												0				
10:45												0				
11:00	0	0	0	0	0	0	3	1	0	0	0	5				
11:15	0	0	0	0	1	0	0	0	0	0	1	3				
11:30	0	0	0	0	1	0	0	0	0	0	0	1				
11:45	0	0	1	0	0	0	1	1	0	0	0	3				
12:00	0	0	0	0	0	0	0	0	0	0	0	0				
12:15	0	0	0	0	0	0	1	0	0	0	0	1				
12:30	1	0	0	0	0	1	0	0	0	1	2	7				
12:45	0	0	2	1	1	0	3	0	0	1	2	11				
13:00												0				
13:15												0				
13:30												0				
13:45												0				
14:00												0				
14:15												0				
14:30												0				
14:45												0				
15:00												0				
15:15												0				
15:30												0				
15:45	0	0	4	0	2	0	0	0	0	1	2	9				
16:00												0				
16:15	2	0	2	0	0	0	0	1	0	0	0	11				
16:30	7	0	2	0	1	0	0	0	0	0	0	17				
16:45	1	0	1	0	3	0	1	0	0	0	0	8				
17:00	10	0	0	0	3	0	0	0	0	0	4	18				
17:15	6	0	0	0	4	1	4	1	0	0	8	24				
17:30	5	0	2	0	2	1	0	1	0	0	2	15				
17:45	1	0	1	1	0	1	0	0	0	0	0	5				
18:00												0				
18:15												0				
18:30												0				
18:45												0				
19:00												0				
19:15												0				
19:30												0				
19:45												0				
20:00												0				
20:15												0				
20:30												0				
20:45												0				
21:00												0				
21:15												0				
21:30												0				
21:45												0				
22:00												0				
22:15												0				
22:30												0				
22:45												0				
23:00												0				
23:15												0				
23:30												0				
23:45												0				
Total	33	0	93	4	19	6	37	8	0	0	27	5	84	11	327	
AM Peak Hr:																7:15
PK Vol	0	0	67	2	0	0	18	0	0	0	0	1	1	61	3	153
MID Peak Hr:																11:45
PK Vol	1	0	1	0	0	0	2	2	0	0	0	1	0	2	2	11
PM Peak Hr:																16:30
PK Vol	24	0	3	0	11	1	5	1	0	0	0	0	19	1	2	67

Intersection ID: 1805133
Count Date: 11/29/2018

N 7TH ST & E HIGHLAND AVE

From North (SB) From East (WB) From South (NB) From West (EB)
N 7TH ST E HIGHLAND AVE N 7TH ST E HIGHLAND AVE INTSEC

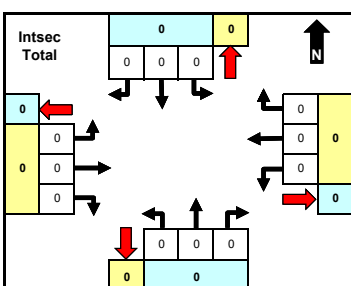
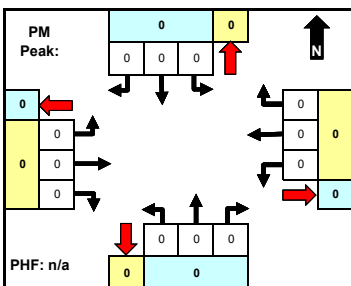
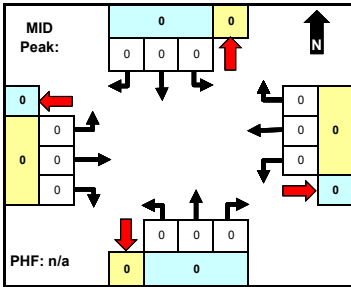
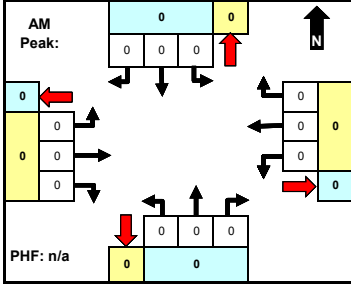

	North		East		South		West		Total
	App	Dep	App	Dep	App	Dep	App	Dep	
AM	0	0	0	0	0	0	0	0	0
MID	0	0	0	0	0	0	0	0	0
PM	0	0	0	0	0	0	0	0	0
Total	0	0	0	0	0	0	0	0	0

Comments
Unless shown otherwise, MID period defined as 10:00 AM - 2:00 PM. Peaks defined based on total intersection volume for all vehicle types.

Time	From North (SB) N 7TH ST				From East (WB) E HIGHLAND AVE				From South (NB) N 7TH ST				From West (EB) E HIGHLAND AVE				INTSEC	TOTAL
	LT	Thru	RT	U	LT	Thru	RT	U	LT	Thru	RT	U	LT	Thru	RT	U		
0:00																		0
0:15																		0
0:30																		0
0:45																		0
1:00																		0
1:15																		0
1:30																		0
1:45																		0
2:00																		0
2:15																		0
2:30																		0
2:45																		0
3:00																		0
3:15																		0
3:30																		0
3:45																		0
4:00																		0
4:15																		0
4:30																		0
4:45																		0
5:00																		0
5:15																		0
5:30																		0
5:45																		0
6:00																		0
6:15																		0
6:30	0	0	0	0	0	0	0	0	0	0	0	0	0	0	0	0	0	0
6:45	0	0	0	0	0	0	0	0	0	0	0	0	0	0	0	0	0	0
7:00	0	0	0	0	0	0	0	0	0	0	0	0	0	0	0	0	0	0
7:15	0	0	0	0	0	0	0	0	0	0	0	0	0	0	0	0	0	0
7:30	0	0	0	0	0	0	0	0	0	0	0	0	0	0	0	0	0	0
7:45	0	0	0	0	0	0	0	0	0	0	0	0	0	0	0	0	0	0
8:00	0	0	0	0	0	0	0	0	0	0	0	0	0	0	0	0	0	0
8:15	0	0	0	0	0	0	0	0	0	0	0	0	0	0	0	0	0	0
8:30																		0
8:45																		0
9:00																		0
9:15																		0
9:30																		0
9:45																		0
10:00																		0
10:15																		0
10:30																		0
10:45																		0
11:00	0	0	0	0	0	0	0	0	0	0	0	0	0	0	0	0	0	0
11:15	0	0	0	0	0	0	0	0	0	0	0	0	0	0	0	0	0	0
11:30	0	0	0	0	0	0	0	0	0	0	0	0	0	0	0	0	0	0
11:45	0	0	0	0	0	0	0	0	0	0	0	0	0	0	0	0	0	0
12:00	0	0	0	0	0	0	0	0	0	0	0	0	0	0	0	0	0	0
12:15	0	0	0	0	0	0	0	0	0	0	0	0	0	0	0	0	0	0
12:30	0	0	0	0	0	0	0	0	0	0	0	0	0	0	0	0	0	0
12:45	0	0	0	0	0	0	0	0	0	0	0	0	0	0	0	0	0	0
13:00																		0
13:15																		0
13:30																		0
13:45																		0
14:00																		0
14:15																		0
14:30																		0
14:45																		0
15:00																		0
15:15																		0
15:30																		0
15:45																		0
16:00	0	0	0	0	0	0	0	0	0	0	0	0	0	0	0	0	0	0
16:15	0	0	0	0	0	0	0	0	0	0	0	0	0	0	0	0	0	0
16:30	0	0	0	0	0	0	0	0	0	0	0	0	0	0	0	0	0	0
16:45	0	0	0	0	0	0	0	0	0	0	0	0	0	0	0	0	0	0
17:00	0	0	0	0	0	0	0	0	0	0	0	0	0	0	0	0	0	0
17:15	0	0	0	0	0	0	0	0	0	0	0	0	0	0	0	0	0	0
17:30	0	0	0	0	0	0	0	0	0	0	0	0	0	0	0	0	0	0
17:45	0	0	0	0	0	0	0	0	0	0	0	0	0	0	0	0	0	0
18:00																		0
18:15																		0
18:30																		0
18:45																		0
19:00																		0
19:15																		0
19:30																		0
19:45																		0
20:00																		0
20:15																		0
20:30																		0
20:45																		0
21:00																		0
21:15																		0
21:30																		0
21:45																		0
22:00																		0
22:15																		0
22:30																		0
22:45																		0
23:00																		0
23:15																		0
23:30																		0
23:45																		0
Total	0	0	0	0	0	0	0	0	0	0	0	0	0	0	0	0	0	0
AM Peak Hr:																	7:15	
Pk Vol	0	0	0	0	0	0	0	0	0	0	0	0	0	0	0	0	0	0
PHF	n/a	n/a	n/a	n/a	n/a	n/a	n/a	n/a	n/a	n/a	n/a	n/a	n/a	n/a	n/a	n/a	n/a	n/a
MID Peak Hr:																	11:45	
Pk Vol	0	0	0	0	0	0	0	0	0	0	0	0	0	0	0	0	0	0
PHF	n/a	n/a	n/a	n/a	n/a	n/a	n/a	n/a	n/a	n/a	n/a	n/a	n/a	n/a	n/a	n/a	n/a	n/a
PM Peak Hr:																	16:30	
Pk Vol	0	0	0	0	0	0	0	0	0	0	0	0	0	0	0	0	0	0
PHF	n/a	n/a	n/a	n/a	n/a	n/a	n/a	n/a	n/a	n/a	n/a	n/a	n/a	n/a	n/a	n/a	n/a	n/a

Intersection ID: 1805134
Count Date: 11/29/2018

N 7TH ST & E CAMELBACK RD

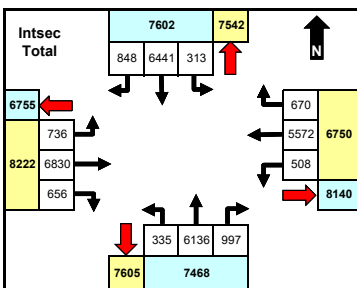
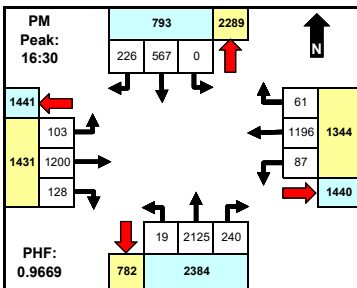
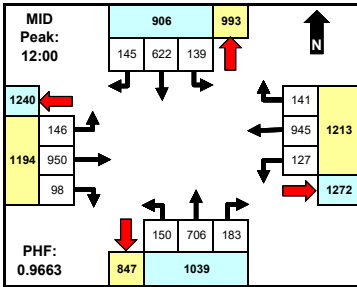
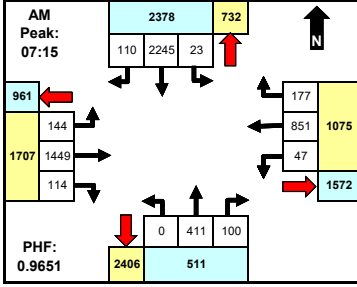

	North		East		South		West		Total
	App	Dep	App	Dep	App	Dep	App	Dep	
AM	2378	732	1075	1572	511	2406	1707	961	5671
MID	906	993	1213	1272	1039	847	1194	1240	4352
PM	793	2289	1344	1440	2384	782	1431	1441	5952
Total	7602	7542	6750	8140	7468	7605	8222	6755	30042

From North (SB) From East (WB) From South (NB) From West (EB) INTSEC

Time	N 7TH ST				E CAMELBACK RD				N 7TH ST				E CAMELBACK RD				TOTAL
	LT	Thru	RT	U	LT	Thru	RT	U	LT	Thru	RT	U	LT	Thru	RT	U	
0:00																	0
0:15																	0
0:30																	0
0:45																	0
1:00																	0
1:15																	0
1:30																	0
1:45																	0
2:00																	0
2:15																	0
2:30																	0
2:45																	0
3:00																	0
3:15																	0
3:30																	0
3:45																	0
4:00																	0
4:15																	0
4:30																	0
4:45																	0
5:00																	0
5:15																	0
5:30																	0
5:45																	0
6:00																	0
6:15																	0
6:30	2	355	20	0	9	115	17	0	0	58	17	0	23	273	10	0	899
6:45	7	530	17	0	2	81	21	0	0	66	17	0	34	264	10	0	1049
7:00	1	517	20	0	9	164	38	0	0	62	15	0	39	315	19	0	1199
7:15	13	580	22	0	12	174	44	0	0	95	26	0	29	309	27	0	1331
7:30	2	556	28	0	10	232	50	0	0	107	26	0	51	380	27	0	1469
7:45	6	587	33	0	16	235	40	0	0	100	23	0	27	363	30	0	1460
8:00	2	522	27	0	9	210	43	0	0	109	25	0	37	397	30	0	1411
8:15	6	472	31	0	14	169	25	0	0	151	33	0	26	378	21	0	1326
8:30																	0
8:45																	0
9:00																	0
9:15																	0
9:30																	0
9:45																	0
10:00																	0
10:15																	0
10:30																	0
10:45																	0
11:00	32	122	27	0	35	212	24	0	31	143	43	0	30	210	32	0	941
11:15	31	146	26	0	38	214	21	0	27	152	44	0	29	236	21	0	985
11:30	30	137	32	0	28	208	29	0	39	130	31	0	34	219	36	0	953
11:45	37	180	37	0	25	188	29	0	34	169	55	0	38	255	30	0	1077
12:00	24	139	36	0	32	252	42	0	39	165	46	0	31	231	26	0	1063
12:15	43	166	33	0	31	210	31	0	42	191	49	0	40	225	22	0	1083
12:30	33	147	42	0	31	276	33	0	28	169	46	0	35	260	26	0	1126
12:45	39	170	34	0	33	207	35	0	41	181	42	0	40	234	24	0	1080
13:00																	0
13:15																	0
13:30																	0
13:45																	0
14:00																	0
14:15																	0
14:30																	0
14:45																	0
15:00																	0
15:15																	0
15:30																	0
15:45																	0
16:00	5	136	5	0	12	276	20	0	10	491	63	0	16	258	34	0	1326
16:15	0	117	54	0	24	343	22	0	4	456	57	0	16	297	32	0	1422
16:30	0	144	61	0	14	280	12	0	4	548	69	0	16	316	28	0	1492
16:45	0	129	49	0	28	322	17	0	6	495	50	0	32	300	33	0	1461
17:00	0	161	69	0	20	287	19	0	3	582	71	0	26	266	35	0	1539
17:15	0	133	47	0	25	307	13	0	6	500	50	0	29	318	32	0	1460
17:30	0	146	53	0	20	276	18	0	9	526	46	0	18	254	47	0	1413
17:45	0	149	45	0	31	334	27	0	12	490	53	0	40	272	24	0	1477
18:00																	0
18:15																	0
18:30																	0
18:45																	0
19:00																	0
19:15																	0
19:30																	0
19:45																	0
20:00																	0
20:15																	0
20:30																	0
20:45																	0
21:00																	0
21:15																	0
21:30																	0
21:45																	0
22:00																	0
22:15																	0
22:30																	0
22:45																	0
23:00																	0
23:15																	0
23:30																	0
23:45																	0
Total	313	6441	848	0	508	5572	670	0	335	6136	997	0	736	6830	656	0	30042
AM Peak Hr:																	7:15
Pk Vol	23	2245	110	0	47	851	177	0	0	411	100	0	144	1449	114	0	5671
PHF	0.442	0.956	0.833	n/a	0.734	0.905	0.885	n/a	n/a	0.943	0.962	n/a	0.706	0.912	0.950	n/a	0.965
MID Peak Hr:																	12:00
Pk Vol	139	622	145	0	127	945	141	0	150	706	183	0	146	950	98	0	4352
PHF	0.808	0.915	0.863	n/a	0.962	0.856	0.839	n/a	0.893	0.924	0.934	n/a	0.913	0.913	0.942	n/a	0.965
PM Peak Hr:																	16:30
Pk Vol	0	567	226	0	87	1196	61	0	19	2126	240	0	103	1200	128	0	5952
PHF	n/a	0.880	0.819	n/a	0.777	0.929	0.803	n/a	0.792	0.913	0.845	n/a	0.805	0.943	0.914	n/a	0.967

Comments

Unless shown otherwise, MID period defined as 10:00 AM - 2:00 PM. Peaks defined based on total intersection volume for all vehicle types.

Intersection ID: 1805134
Count Date: 11/29/2018

N 7TH ST & E CAMELBACK RD

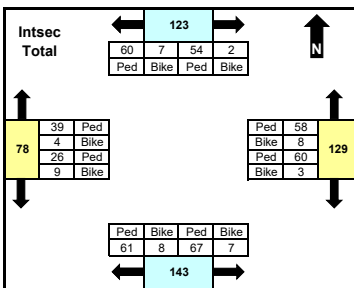
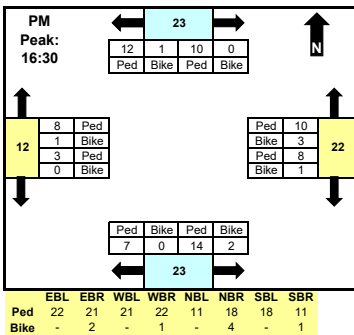
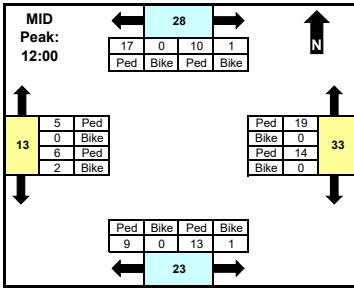
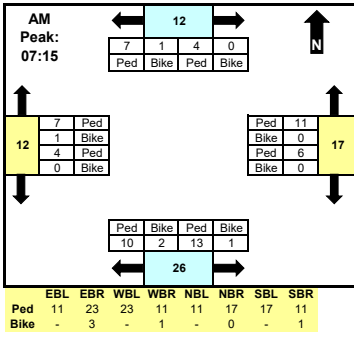

	North		East		South		West		Total
	CW	CCW	CW	CCW	CW	CCW	CW	CCW	
AM	4	8	6	11	12	14	8	4	67
MID	11	17	14	19	9	14	5	8	97
PM	10	13	9	13	7	16	9	3	80
Total	56	67	63	66	69	74	43	35	473

CW = Clockwise
CCW = Counter-clockwise

Comments
Unless shown otherwise, MID period defined as 10:00 AM - 2:00 PM. Crosswalk peaks defined based on total intersection volume for all vehicle types.

Time	North Leg		East Leg		South Leg		West Leg		INTSEC	TOTAL								
	CW	CCW	CW	CCW	CW	CCW	CW	CCW										
0:00										0								
0:15										0								
0:30										0								
0:45										0								
1:00										0								
1:15										0								
1:30										0								
1:45										0								
2:00										0								
2:15										0								
2:30										0								
2:45										0								
3:00										0								
3:15										0								
3:30										0								
3:45										0								
4:00										0								
4:15										0								
4:30										0								
4:45										0								
5:00										0								
5:15										0								
5:30										0								
5:45										0								
6:00										0								
6:15										0								
6:30	1	0	0	1	1	0	2	0	3	0	6	0	1	0	0	1	16	
6:45	2	0	0	0	7	0	1	0	3	0	1	0	0	0	0	0	1	17
7:00	3	0	3	0	2	1	1	1	0	1	2	1	1	1	0	0	1	17
7:15	1	0	3	0	0	0	1	0	1	0	5	1	0	0	2	0	2	14
7:30	0	0	1	0	1	0	1	0	1	0	2	0	1	0	1	0	1	8
7:45	1	0	1	1	3	0	6	0	4	1	3	0	1	1	0	0	22	
8:00	2	0	2	0	2	0	3	0	4	1	3	0	5	0	1	0	23	
8:15	4	0	1	0	3	0	1	0	1	0	1	0	3	0	2	0	16	
8:30																	0	
8:45																	0	
9:00																	0	
9:15																	0	
9:30																	0	
9:45																	0	
10:00																	0	
10:15																	0	
10:30																	0	
10:45																	0	
11:00	1	0	3	0	1	0	2	0	5	1	4	0	2	1	0	0	20	
11:15	2	0	1	1	4	0	0	3	1	1	0	1	1	2	0	0	17	
11:30	4	0	3	0	2	0	6	0	3	0	4	0	2	0	0	1	25	
11:45	5	1	2	0	4	1	1	0	4	0	0	0	3	0	3	0	24	
12:00	3	1	6	0	1	0	4	0	2	0	6	0	2	0	0	0	25	
12:15	2	0	3	0	6	0	7	0	1	0	5	1	1	0	2	0	28	
12:30	3	0	6	0	6	0	6	0	5	0	1	0	2	0	3	2	34	
12:45	2	0	2	0	1	0	2	0	1	0	1	0	0	0	1	0	10	
13:00																	0	
13:15																	0	
13:30																	0	
13:45																	0	
14:00																	0	
14:15																	0	
14:30																	0	
14:45																	0	
15:00																	0	
15:15																	0	
15:30																	0	
15:45																	0	
16:00	5	0	6	0	2	0	2	1	5	0	1	1	2	0	0	0	25	
16:15	1	0	3	2	3	0	1	1	0	0	6	1	3	0	1	2	24	
16:30	3	0	2	1	3	0	3	1	1	0	4	1	4	1	2	0	26	
16:45	0	0	3	0	0	1	1	0	1	0	1	0	0	0	1	0	8	
17:00	0	0	2	0	1	0	4	1	3	0	6	1	2	0	0	0	20	
17:15	7	0	5	0	4	0	2	1	2	0	3	0	2	0	0	0	26	
17:30	0	0	1	0	2	0	0	2	2	2	0	0	0	0	3	2	14	
17:45	2	0	1	1	1	0	1	0	6	1	1	0	1	0	1	0	16	
18:00																	0	
18:15																	0	
18:30																	0	
18:45																	0	
19:00																	0	
19:15																	0	
19:30																	0	
19:45																	0	
20:00																	0	
20:15																	0	
20:30																	0	
20:45																	0	
21:00																	0	
21:15																	0	
21:30																	0	
21:45																	0	
22:00																	0	
22:15																	0	
22:30																	0	
22:45																	0	
23:00																	0	
23:15																	0	
23:30																	0	
23:45																	0	
Total	54	2	60	7	60	3	58	8	61	8	67	7	39	4	26	9	473	
AM Peak Hr:																	7:15	
PK Vol	4	0	7	1	6	0	11	0	10	2	13	1	7	1	4	0	67	
MID Peak Hr:																	12:00	
PK Vol	10	1	17	0	14	0	19	0	9	0	13	1	5	0	6	2	97	
PM Peak Hr:																	16:30	
PK Vol	10	0	12	1	8	1	10	3	7	0	14	2	8	1	3	0	80	

Intersection ID: 1805134
Count Date: 11/29/2018

N 7TH ST & E CAMELBACK RD

From North (SB) From East (WB) From South (NB) From West (EB)
N 7TH ST E CAMELBACK RD N 7TH ST E CAMELBACK RD INTSEC

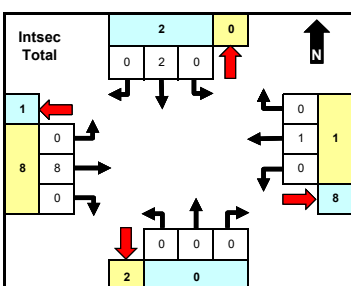
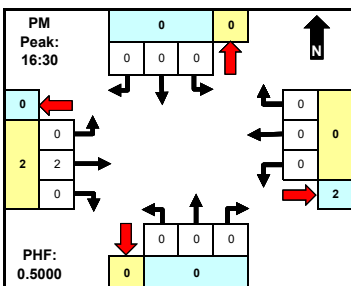
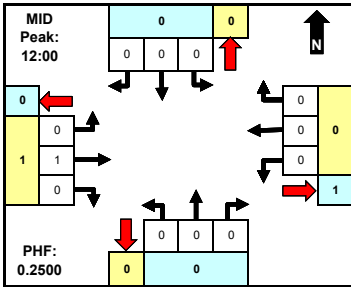
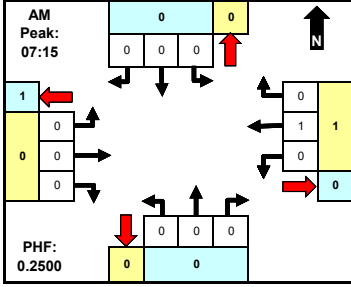

	North		East		South		West		Total
	App	Dep	App	Dep	App	Dep	App	Dep	
AM	0	0	1	0	0	0	0	0	1
MID	0	0	0	1	0	0	1	0	1
PM	0	0	0	2	0	0	2	0	2
Total	2	0	1	8	0	2	8	1	11

Comments
Unless shown otherwise, MID period defined as 10:00 AM - 2:00 PM. Peaks defined based on total intersection volume for all vehicle types.

Time	From North (SB)				From East (WB)				From South (NB)				From West (EB)				TOTAL
	LT	Thru	RT	U	LT	Thru	RT	U	LT	Thru	RT	U	LT	Thru	RT	U	
0:00																	0
0:15																	0
0:30																	0
0:45																	0
1:00																	0
1:15																	0
1:30																	0
1:45																	0
2:00																	0
2:15																	0
2:30																	0
2:45																	0
3:00																	0
3:15																	0
3:30																	0
3:45																	0
4:00																	0
4:15																	0
4:30																	0
4:45																	0
5:00																	0
5:15																	0
5:30																	0
5:45																	0
6:00																	0
6:15																	0
6:30	0	0	0	0	0	0	0	0	0	0	0	0	0	1	0	0	1
6:45	0	0	0	0	0	0	0	0	0	0	0	0	0	1	0	0	1
7:00	0	0	0	0	0	0	0	0	0	0	0	0	0	0	0	0	0
7:15	0	0	0	0	0	0	0	0	0	0	0	0	0	0	0	0	0
7:30	0	0	0	0	0	0	0	0	0	0	0	0	0	0	0	0	0
7:45	0	0	0	0	0	0	0	0	0	1	0	0	0	0	0	0	1
8:00	0	0	0	0	0	0	0	0	0	0	0	0	0	0	0	0	0
8:15	0	0	0	0	0	0	0	0	0	0	0	0	0	1	0	0	1
8:30																	0
8:45																	0
9:00																	0
9:15																	0
9:30																	0
9:45																	0
10:00																	0
10:15																	0
10:30																	0
10:45																	0
11:00	0	0	0	0	0	0	0	0	0	0	0	0	0	0	0	0	0
11:15	0	0	0	0	0	0	0	0	0	0	0	0	0	0	0	0	0
11:30	0	0	0	0	0	0	0	0	0	0	0	0	0	0	0	0	0
11:45	0	0	0	0	0	0	0	0	0	0	0	0	0	1	0	0	1
12:00	0	0	0	0	0	0	0	0	0	0	0	0	0	0	0	0	0
12:15	0	0	0	0	0	0	0	0	0	0	0	0	0	0	0	0	0
12:30	0	0	0	0	0	0	0	0	0	0	0	0	0	1	0	0	1
12:45	0	0	0	0	0	0	0	0	0	0	0	0	0	0	0	0	0
13:00																	0
13:15																	0
13:30																	0
13:45																	0
14:00																	0
14:15																	0
14:30																	0
14:45																	0
15:00																	0
15:15																	0
15:30																	0
15:45																	0
16:00	0	0	0	0	0	0	0	0	0	0	0	0	0	0	0	0	0
16:15	0	1	0	0	0	0	0	0	0	0	0	0	0	1	0	0	2
16:30	0	0	0	0	0	0	0	0	0	0	0	0	0	1	0	0	1
16:45	0	0	0	0	0	0	0	0	0	0	0	0	0	1	0	0	1
17:00	0	0	0	0	0	0	0	0	0	0	0	0	0	0	0	0	0
17:15	0	0	0	0	0	0	0	0	0	0	0	0	0	0	0	0	0
17:30	0	1	0	0	0	0	0	0	0	0	0	0	0	0	0	0	1
17:45	0	0	0	0	0	0	0	0	0	0	0	0	0	0	0	0	0
18:00																	0
18:15																	0
18:30																	0
18:45																	0
19:00																	0
19:15																	0
19:30																	0
19:45																	0
20:00																	0
20:15																	0
20:30																	0
20:45																	0
21:00																	0
21:15																	0
21:30																	0
21:45																	0
22:00																	0
22:15																	0
22:30																	0
22:45																	0
23:00																	0
23:15																	0
23:30																	0
23:45																	0
Total	0	2	0	0	0	0	1	0	0	0	0	0	0	8	0	0	11
AM Peak Hr:																	7:15
Pk Vol	0	0	0	0	0	0	1	0	0	0	0	0	0	0	0	0	1
PHF	n/a	n/a	n/a	n/a	n/a	0.250	n/a	n/a	n/a	n/a	n/a	n/a	n/a	n/a	n/a	n/a	0.250
MID Peak Hr:																	12:00
Pk Vol	0	0	0	0	0	0	0	0	0	0	0	0	0	1	0	0	1
PHF	n/a	n/a	n/a	n/a	n/a	n/a	n/a	n/a	n/a	n/a	n/a	n/a	n/a	0.250	n/a	n/a	0.250
PM Peak Hr:																	16:30
Pk Vol	0	0	0	0	0	0	0	0	0	0	0	0	0	2	0	0	2
PHF	n/a	n/a	n/a	n/a	n/a	n/a	n/a	n/a	n/a	n/a	n/a	n/a	n/a	0.500	n/a	n/a	0.500

Intersection ID: 1805135
Count Date: 11/29/2018

N 7TH ST & E MISSOURI AVE

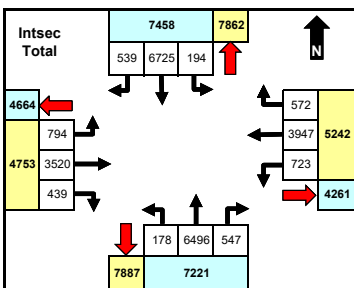
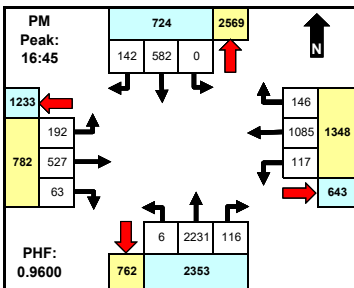
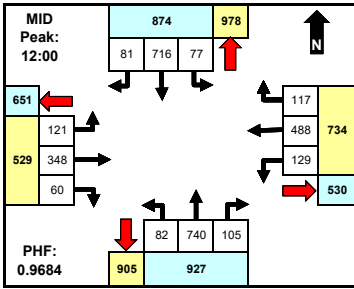
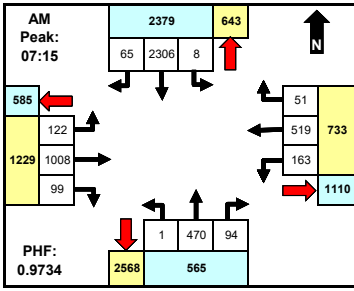

	North		East		South		West		Total
	App	Dep	App	Dep	App	Dep	App	Dep	
AM	2379	643	733	1110	585	2568	1229	585	4906
MID	874	978	734	530	927	905	529	651	3064
PM	724	2569	1348	643	2353	762	782	1233	5207
Total	7458	7862	5242	4261	7221	7887	4753	4664	24674

Comments

Unless shown otherwise, MID period defined as 10:00 AM - 2:00 PM. Peaks defined based on total intersection volume for all vehicle types.

Time	From North (SB)				From East (WB)				From South (NB)				From West (EB)				INTSEC	TOTAL
	LT	Thru	RT	U	LT	Thru	RT	U	LT	Thru	RT	U	LT	Thru	RT	U		
0:00																	0	
0:15																	0	
0:30																	0	
0:45																	0	
1:00																	0	
1:15																	0	
1:30																	0	
1:45																	0	
2:00																	0	
2:15																	0	
2:30																	0	
2:45																	0	
3:00																	0	
3:15																	0	
3:30																	0	
3:45																	0	
4:00																	0	
4:15																	0	
4:30																	0	
4:45																	0	
5:00																	0	
5:15																	0	
5:30																	0	
5:45																	0	
6:00																	0	
6:15																	0	
6:30		5	438	10	0	14	51	2	0	0	67	12	0	11	149	12	0	771
6:45		1	493	18	0	26	55	6	0	0	62	11	0	17	206	25	0	920
7:00		0	508	11	0	34	79	8	0	0	88	11	0	24	223	18	0	1004
7:15		2	523	11	0	41	114	8	0	1	102	19	0	35	268	22	0	1146
7:30		2	597	20	0	48	128	12	0	0	127	25	0	34	232	25	0	1250
7:45		2	586	14	0	29	153	20	0	0	106	22	0	22	267	29	0	1256
8:00		2	600	20	0	45	124	11	0	0	135	28	0	31	241	23	0	1260
8:15		4	402	13	0	39	119	14	0	1	119	23	0	28	206	21	0	989
8:30																	0	0
8:45																	0	0
9:00																	0	0
9:15																	0	0
9:30																	0	0
9:45																	0	0
10:00																	0	0
10:15																	0	0
10:30																	0	0
10:45																	0	0
11:00	34	154	17	0	26	94	18	0	15	199	15	0	30	73	19	0	694	
11:15	13	177	12	0	23	101	31	0	10	174	15	0	38	80	19	0	693	
11:30	24	195	18	0	33	96	32	0	15	156	27	0	26	68	14	0	704	
11:45	26	181	18	0	41	110	30	0	13	164	16	0	35	105	26	0	765	
12:00	16	159	25	0	39	109	29	0	21	180	32	0	29	77	16	0	732	
12:15	15	187	18	0	34	127	40	0	23	184	22	0	36	89	16	0	791	
12:30	24	172	19	0	21	136	27	0	21	183	22	0	28	91	12	0	756	
12:45	22	198	19	0	35	116	21	0	17	193	29	0	28	91	16	0	785	
13:00																	0	0
13:15																	0	0
13:30																	0	0
13:45																	0	0
14:00																	0	0
14:15																	0	0
14:30																	0	0
14:45																	0	0
15:00																	0	0
15:15																	0	0
15:30																	0	0
15:45																	0	0
16:00	1	137	37	0	20	246	26	0	19	472	19	0	35	134	17	0	1163	
16:15	0	142	33	0	20	320	25	0	5	547	30	0	26	120	13	0	1281	
16:30	1	127	24	0	19	316	29	0	3	491	33	0	41	143	17	0	1244	
16:45	0	158	41	0	25	271	29	0	3	574	28	0	49	109	15	0	1302	
17:00	0	124	34	0	33	273	33	0	2	535	33	0	51	147	19	0	1284	
17:15	0	161	38	0	31	264	45	0	0	621	27	0	43	113	13	0	1356	
17:30	0	139	29	0	28	277	39	0	1	501	28	0	49	158	16	0	1265	
17:45	0	167	40	0	19	268	37	0	8	516	20	0	48	130	16	0	1269	
18:00																	0	0
18:15																	0	0
18:30																	0	0
18:45																	0	0
19:00																	0	0
19:15																	0	0
19:30																	0	0
19:45																	0	0
20:00																	0	0
20:15																	0	0
20:30																	0	0
20:45																	0	0
21:00																	0	0
21:15																	0	0
21:30																	0	0
21:45																	0	0
22:00																	0	0
22:15																	0	0
22:30																	0	0
22:45																	0	0
23:00																	0	0
23:15																	0	0
23:30																		

Intersection ID: 1805135
Count Date: 11/29/2018

N 7TH ST & E MISSOURI AVE

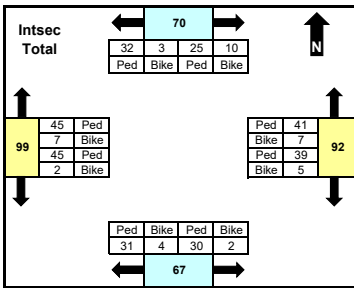
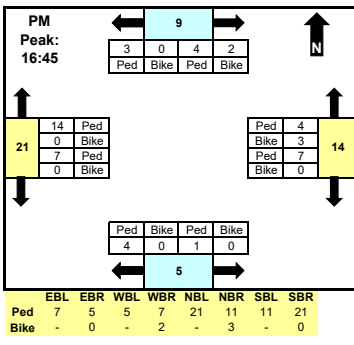
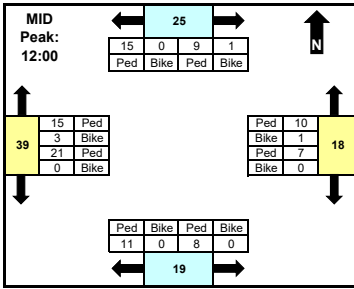
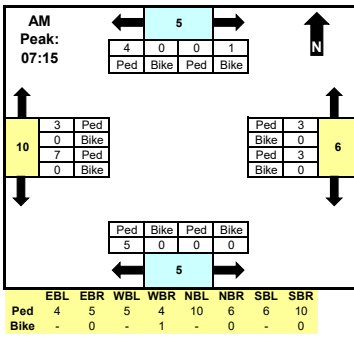

	North		East		South		West		Total
	CW	CCW	CW	CCW	CW	CCW	CW	CCW	
AM	1	4	3	3	5	0	3	7	26
MID	10	15	7	11	11	8	18	21	101
PM	6	3	7	7	4	1	14	7	49
Total	35	35	44	48	35	32	52	47	328

CW = Clockwise
CCW = Counter-clockwise

Comments
Unless shown otherwise, MID period defined as 10:00 AM - 2:00 PM. Crosswalk peaks defined based on total intersection volume for all vehicle types.

Time	North Leg		East Leg		South Leg		West Leg		INTSEC	TOTAL							
	CW	CCW	CW	CCW	CW	CCW	CW	CCW									
0:00										0							
0:15										0							
0:30										0							
0:45										0							
1:00										0							
1:15										0							
1:30										0							
1:45										0							
2:00										0							
2:15										0							
2:30										0							
2:45										0							
3:00										0							
3:15										0							
3:30										0							
3:45										0							
4:00										0							
4:15										0							
4:30										0							
4:45										0							
5:00										0							
5:15										0							
5:30										0							
5:45										0							
6:00										0							
6:15										0							
6:30	0	0	2	0	0	0	0	0	0	3							
6:45	0	0	0	0	3	0	2	0	0	7							
7:00	1	0	0	0	1	0	0	0	0	2							
7:15	0	0	0	0	0	1	0	0	0	3							
7:30	0	0	0	0	0	0	0	0	0	5							
7:45	0	1	2	0	2	0	3	0	2	12							
8:00	0	0	2	0	1	0	2	0	0	6							
8:15	0	1	1	0	0	0	0	0	1	8							
8:30										0							
8:45										0							
9:00										0							
9:15										0							
9:30										0							
9:45										0							
10:00										0							
10:15										0							
10:30										0							
10:45										0							
11:00	2	1	0	0	3	0	0	0	0	12							
11:15	0	0	1	0	2	0	7	0	1	14							
11:30	2	0	1	0	2	0	2	0	0	8							
11:45	4	1	0	0	5	2	5	0	4	29							
12:00	5	1	1	0	3	0	2	0	3	32							
12:15	0	0	6	0	3	0	3	1	5	24							
12:30	2	0	5	0	1	0	3	0	2	26							
12:45	2	0	3	0	0	0	2	0	1	19							
13:00										0							
13:15										0							
13:30										0							
13:45										0							
14:00										0							
14:15										0							
14:30										0							
14:45										0							
15:00										0							
15:15										0							
15:30										0							
15:45	0	2	1	0	1	2	2	1	2	20							
16:15	1	0	1	1	4	0	2	2	0	19							
16:30	2	0	0	2	0	1	2	0	0	15							
16:45	0	1	3	0	4	0	1	0	3	16							
17:00	1	1	0	0	0	0	1	0	0	10							
17:15	3	0	0	0	1	0	0	0	0	10							
17:30	0	0	0	0	2	0	2	3	0	13							
17:45	0	1	3	0	1	0	2	0	0	15							
18:00										0							
18:15										0							
18:30										0							
18:45										0							
19:00										0							
19:15										0							
19:30										0							
19:45										0							
20:00										0							
20:15										0							
20:30										0							
20:45										0							
21:00										0							
21:15										0							
21:30										0							
21:45										0							
22:00										0							
22:15										0							
22:30										0							
22:45										0							
23:00										0							
23:15										0							
23:30										0							
23:45										0							
Total	25	10	32	3	39	5	41	7	31	4	30	2	45	7	45	2	328
AM Peak Hr:																	7:15
PK Vol	0	1	4	0	3	0	3	0	5	0	0	0	3	0	7	0	26
MID Peak Hr:																	12:00
PK Vol	9	1	15	0	7	0	10	1	11	0	8	0	15	3	21	0	101
PM Peak Hr:																	16:45
PK Vol	4	2	3	0	7	0	4	3	4	0	1	0	14	0	7	0	49

Intersection ID: 1805135
Count Date: 11/29/2018

N 7TH ST & E MISSOURI AVE

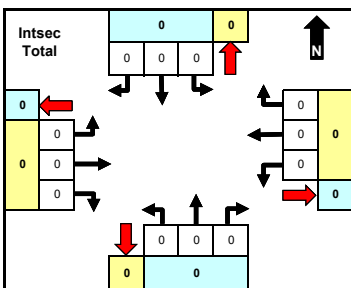
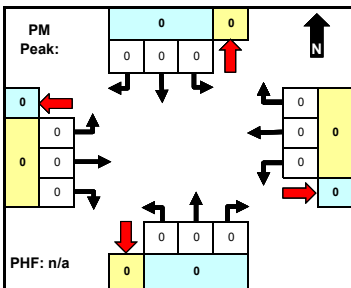
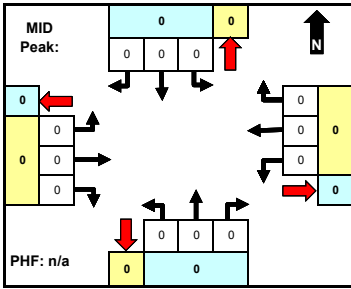
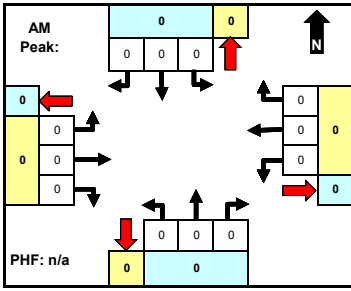

	North		East		South		West		Total
	App	Dep	App	Dep	App	Dep	App	Dep	
AM	0	0	0	0	0	0	0	0	0
MID	0	0	0	0	0	0	0	0	0
PM	0	0	0	0	0	0	0	0	0
Total	0	0	0	0	0	0	0	0	0

Comments
Unless shown otherwise, MID period defined as 10:00 AM - 2:00 PM. Peaks defined based on total intersection volume for all vehicle types.

Time	From North (SB)				From East (WB)				From South (NB)				From West (EB)				INTSEC	TOTAL
	N 7TH ST		E MISSOURI AVE		N 7TH ST		E MISSOURI AVE		N 7TH ST		E MISSOURI AVE		N 7TH ST		E MISSOURI AVE			
	LT	Thru	RT	U	LT	Thru	RT	U	LT	Thru	RT	U	LT	Thru	RT	U		
0:00																	0	
0:15																	0	
0:30																	0	
0:45																	0	
1:00																	0	
1:15																	0	
1:30																	0	
1:45																	0	
2:00																	0	
2:15																	0	
2:30																	0	
2:45																	0	
3:00																	0	
3:15																	0	
3:30																	0	
3:45																	0	
4:00																	0	
4:15																	0	
4:30																	0	
4:45																	0	
5:00																	0	
5:15																	0	
5:30																	0	
5:45																	0	
6:00																	0	
6:15																	0	
6:30	0	0	0	0	0	0	0	0	0	0	0	0	0	0	0	0	0	
6:45	0	0	0	0	0	0	0	0	0	0	0	0	0	0	0	0	0	
7:00	0	0	0	0	0	0	0	0	0	0	0	0	0	0	0	0	0	
7:15	0	0	0	0	0	0	0	0	0	0	0	0	0	0	0	0	0	
7:30	0	0	0	0	0	0	0	0	0	0	0	0	0	0	0	0	0	
7:45	0	0	0	0	0	0	0	0	0	0	0	0	0	0	0	0	0	
8:00	0	0	0	0	0	0	0	0	0	0	0	0	0	0	0	0	0	
8:15	0	0	0	0	0	0	0	0	0	0	0	0	0	0	0	0	0	
8:30																	0	
8:45																	0	
9:00																	0	
9:15																	0	
9:30																	0	
9:45																	0	
10:00																	0	
10:15																	0	
10:30																	0	
10:45																	0	
11:00	0	0	0	0	0	0	0	0	0	0	0	0	0	0	0	0	0	
11:15	0	0	0	0	0	0	0	0	0	0	0	0	0	0	0	0	0	
11:30	0	0	0	0	0	0	0	0	0	0	0	0	0	0	0	0	0	
11:45	0	0	0	0	0	0	0	0	0	0	0	0	0	0	0	0	0	
12:00	0	0	0	0	0	0	0	0	0	0	0	0	0	0	0	0	0	
12:15	0	0	0	0	0	0	0	0	0	0	0	0	0	0	0	0	0	
12:30	0	0	0	0	0	0	0	0	0	0	0	0	0	0	0	0	0	
12:45	0	0	0	0	0	0	0	0	0	0	0	0	0	0	0	0	0	
13:00																	0	
13:15																	0	
13:30																	0	
13:45																	0	
14:00																	0	
14:15																	0	
14:30																	0	
14:45																	0	
15:00																	0	
15:15																	0	
15:30																	0	
15:45																	0	
16:00	0	0	0	0	0	0	0	0	0	0	0	0	0	0	0	0	0	
16:15	0	0	0	0	0	0	0	0	0	0	0	0	0	0	0	0	0	
16:30	0	0	0	0	0	0	0	0	0	0	0	0	0	0	0	0	0	
16:45	0	0	0	0	0	0	0	0	0	0	0	0	0	0	0	0	0	
17:00	0	0	0	0	0	0	0	0	0	0	0	0	0	0	0	0	0	
17:15	0	0	0	0	0	0	0	0	0	0	0	0	0	0	0	0	0	
17:30	0	0	0	0	0	0	0	0	0	0	0	0	0	0	0	0	0	
17:45	0	0	0	0	0	0	0	0	0	0	0	0	0	0	0	0	0	
18:00																	0	
18:15																	0	
18:30																	0	
18:45																	0	
19:00																	0	
19:15																	0	
19:30																	0	
19:45																	0	
20:00																	0	
20:15																	0	
20:30																	0	
20:45																	0	
21:00																	0	
21:15																	0	
21:30																	0	
21:45																	0	
22:00																	0	
22:15																	0	
22:30																	0	
22:45																	0	
23:00																	0	
23:15																	0	
23:30																	0	
23:45																	0	
Total	0	0	0	0	0	0	0	0	0	0	0	0	0	0	0	0	0	
AM Peak Hr:																	7:15	
Pk Vol	0	0	0	0	0	0	0	0	0	0	0	0	0	0	0	0	0	
PHF	n/a	n/a	n/a	n/a	n/a	n/a	n/a	n/a	n/a	n/a	n/a	n/a	n/a	n/a	n/a	n/a	n/a	
MID Peak Hr:																	12:00	
Pk Vol	0	0	0	0	0	0	0	0	0	0	0	0	0	0	0	0	0	
PHF	n/a	n/a	n/a	n/a	n/a	n/a	n/a	n/a	n/a	n/a	n/a	n/a	n/a	n/a	n/a	n/a	n/a	
PM Peak Hr:																	16:45	
Pk Vol	0	0	0	0	0	0	0	0	0	0	0	0	0	0	0	0	0	
PHF	n/a	n/a	n/a	n/a	n/a	n/a	n/a	n/a	n/a	n/a	n/a	n/a	n/a	n/a	n/a	n/a	n/a	

Intersection ID: 1805136
Count Date: 11/27/2018

N 7TH ST & BETHANY HOME RD

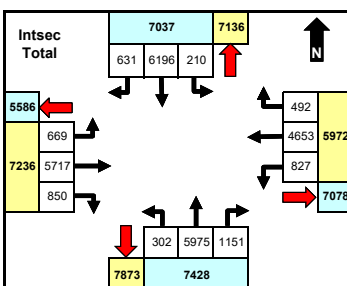
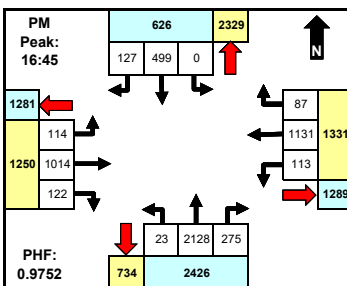
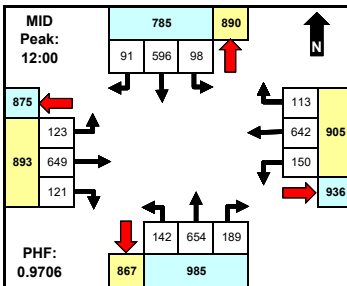
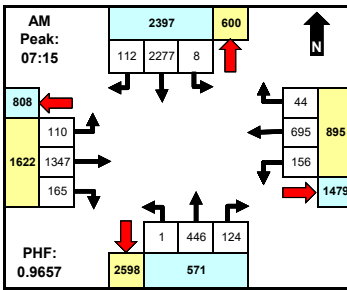

	North	East	South	West	Total				
	App	Dep	App	Dep	App	Dep	App	Dep	Total
AM	2397	600	895	1479	571	2598	1622	808	5485
MID	785	890	905	936	985	867	893	875	3568
PM	626	2329	1331	1289	2426	734	1250	1281	5633
Total	7037	7136	5972	7078	7428	7873	7236	5586	##

Comments

Unless shown otherwise, MID period defined as 10:00 AM - 2:00 PM. Peaks defined based on total intersection volume for all vehicle types.

Time	From North (SB)				From East (WB)				From South (NB)				From West (EB)				INTSEC	TOTAL	
	LT	Thru	RT	U	LT	Thru	RT	U	LT	Thru	RT	U	LT	Thru	RT	U			
0:00																		0	
0:15																		0	
0:30																		0	
0:45																		0	
1:00																		0	
1:15																		0	
1:30																		0	
1:45																		0	
2:00																		0	
2:15																		0	
2:30																		0	
2:45																		0	
3:00																		0	
3:15																		0	
3:30																		0	
3:45																		0	
4:00																		0	
4:15																		0	
4:30																		0	
4:45																		0	
5:00																		0	
5:15																		0	
5:30																		0	
5:45																		0	
6:00																		0	
6:15																		0	
6:30	2	394	18	0	19	99	12	0	0	62	9	0	9	249	23	0	896		
6:45	2	461	14	0	32	125	13	0	1	66	22	0	16	260	47	0	1059		
7:00	3	565	31	0	36	121	8	0	0	92	33	0	25	265	35	0	1214		
7:15	0	573	13	0	36	170	15	0	1	114	27	0	32	366	47	0	1394		
7:30	3	611	31	0	36	171	13	0	0	124	32	0	31	331	37	0	1420		
7:45	2	523	33	0	52	202	9	0	0	111	36	0	26	341	46	0	1381		
8:00	3	570	35	0	32	152	7	0	0	97	29	0	21	309	35	0	1290		
8:15	2	353	21	0	50	140	16	0	2	85	24	0	19	283	44	0	1039		
8:30																		0	
8:45																		0	
9:00																		0	
9:15																		0	
9:30																		0	
9:45																		0	
10:00																		0	
10:15																		0	
10:30																		0	
10:45																		0	
11:00	26	156	23	0	29	144	19	0	24	127	44	0	24	175	40	0	831		
11:15	20	141	18	0	34	150	31	0	29	156	50	0	31	165	42	0	867		
11:30	20	128	23	0	41	116	33	0	37	151	53	0	36	153	43	0	834		
11:45	25	150	30	0	46	153	33	0	24	145	52	0	30	180	49	0	917		
12:00	26	157	25	0	40	145	26	0	28	152	51	0	24	175	30	0	878		
12:15	24	131	22	0	38	176	27	0	40	167	38	0	34	149	33	0	879		
12:30	27	138	29	0	39	145	27	0	39	172	48	0	27	164	37	0	892		
12:45	21	170	15	0	33	176	34	0	35	163	52	0	38	161	21	0	919		
13:00																		0	
13:15																		0	
13:30																		0	
13:45																		0	
14:00																		0	
14:15																		0	
14:30																		0	
14:45																		0	
15:00																		0	
15:15																		0	
15:30																		0	
15:45																		0	
16:00	2	96	32	0	32	274	16	0	4	405	68	0	45	256	38	0	1268		
16:15	0	114	33	0	30	289	24	0	5	533	65	0	19	236	30	0	1378		
16:30	0	116	23	0	22	302	21	0	1	476	67	0	42	263	17	0	1350		
16:45	0	125	40	0	27	273	22	0	9	536	83	0	23	228	27	0	1393		
17:00	0	130	32	0	35	302	29	0	4	509	55	0	26	262	34	0	1418		
17:15	0	134	25	0	26	269	22	0	6	593	70	0	26	255	18	0	1444		
17:30	0	110	30	0	25	287	14	0	4	490	67	0	39	269	43	0	1378		
17:45	2	150	35	0	37	272	22	0	9	449	76	0	26	222	34	0	1334		
18:00																		0	
18:15																		0	
18:30																		0	
18:45																		0	
19:00																		0	
19:15																		0	
19:30																		0	
19:45																		0	
20:00																		0	
20:15																		0	
20:30																		0	
20:45																		0	
21:00																		0	
21:15																		0	
21:30																		0	
21:45																		0	
22:00																		0	
22:15																		0	
22:30																		0	
22:45																		0	
23:00																			

Intersection ID: 1805136
Count Date: 11/27/2018

N 7TH ST & BETHANY HOME RD

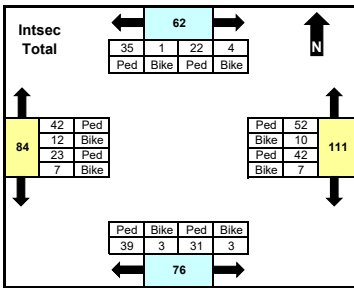
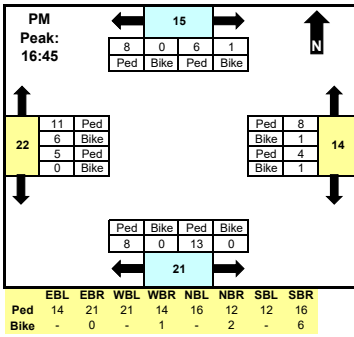
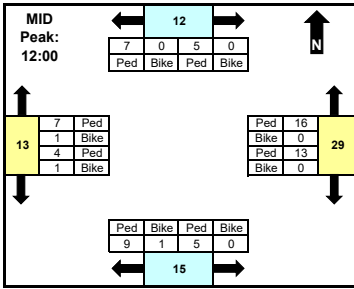
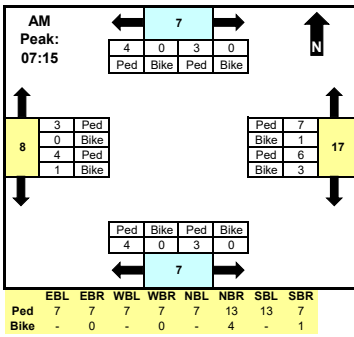

	North		East		South		West		Total
	CW	CCW	CW	CCW	CW	CCW	CW	CCW	
AM	3	4	9	8	4	3	3	5	39
MID	5	7	13	16	10	5	8	5	69
PM	7	8	5	9	8	13	17	5	72
Total	26	36	49	62	42	34	54	30	333

CW = Clockwise
CCW = Counter-clockwise

Comments

Unless shown otherwise, MID period defined as 10:00 AM - 2:00 PM. Crosswalk peaks defined based on total intersection volume for all vehicle types.

Time	North Leg		East Leg		South Leg		West Leg		INTSEC	TOTAL							
	CW	CCW	CW	CCW	CW	CCW	CW	CCW									
0:00										0							
0:15										0							
0:30										0							
0:45										0							
1:00										0							
1:15										0							
1:30										0							
1:45										0							
2:00										0							
2:15										0							
2:30										0							
2:45										0							
3:00										0							
3:15										0							
3:30										0							
3:45										0							
4:00										0							
4:15										0							
4:30										0							
4:45										0							
5:00										0							
5:15										0							
5:30										0							
5:45										0							
6:00										0							
6:15										0							
6:30	0	0	0	0	0	0	0	1	1	4							
6:45	0	0	2	0	1	1	2	1	0	9							
7:00	0	0	1	0	0	1	0	0	0	4							
7:15	0	0	2	0	1	0	3	0	1	9							
7:30	0	0	0	2	1	0	0	0	0	3							
7:45	2	0	1	0	2	1	3	0	2	15							
8:00	1	0	1	0	1	1	1	1	0	12							
8:15	0	0	0	0	0	0	0	0	0	4							
8:30										0							
8:45										0							
9:00										0							
9:15										0							
9:30										0							
9:45										0							
10:00										0							
10:15										0							
10:30										0							
10:45										0							
11:00	2	0	0	0	2	0	1	2	1	9							
11:15	0	0	1	0	2	1	2	0	0	10							
11:30	1	1	1	0	4	0	5	1	4	24							
11:45	2	0	1	0	4	0	2	0	4	21							
12:00	0	0	2	0	2	0	3	0	2	12							
12:15	5	0	2	0	6	0	7	0	3	29							
12:30	0	0	3	0	5	0	3	0	4	22							
12:45	0	0	0	0	0	0	3	0	0	6							
13:00										0							
13:15										0							
13:30										0							
13:45										0							
14:00										0							
14:15										0							
14:30										0							
14:45										0							
15:00										0							
15:15										0							
15:30										0							
15:45	0	1	5	0	3	0	3	2	1	23							
16:00	0	1	1	0	2	1	1	1	1	14							
16:15	3	0	3	0	1	0	0	0	3	17							
16:30	0	0	3	0	2	0	1	0	1	17							
16:45	0	0	3	0	2	0	1	0	1	20							
17:00	3	0	3	0	0	0	2	0	3	21							
17:15	1	1	0	0	1	1	3	0	2	14							
17:30	2	0	2	0	1	0	2	1	2	14							
17:45	0	0	1	0	0	0	4	1	1	10							
18:00										0							
18:15										0							
18:30										0							
18:45										0							
19:00										0							
19:15										0							
19:30										0							
19:45										0							
20:00										0							
20:15										0							
20:30										0							
20:45										0							
21:00										0							
21:15										0							
21:30										0							
21:45										0							
22:00										0							
22:15										0							
22:30										0							
22:45										0							
23:00										0							
23:15										0							
23:30										0							
23:45										0							
Total	22	4	35	1	42	7	52	10	39	3	31	3	42	12	23	7	333

AM Peak Hr:	7:15																
PK Vol	3	0	4	0	6	3	7	1	4	0	3	0	3	0	4	1	39
MID Peak Hr:	12:00																
PK Vol	5	0	7	0	13	0	16	0	9	1	5	0	7	1	4	1	69
PM Peak Hr:	16:45																
PK Vol	6	1	8	0	4	1	8	1	8	0	13	0	11	6	5	0	72

Intersection ID: 1805136
Count Date: 11/27/2018

N 7TH ST & BETHANY HOME RD

From North (SB) From East (WB) From South (NB) From West (EB)
N 7TH ST BETHANY HOME RD N 7TH ST BETHANY HOME RD INTSEC

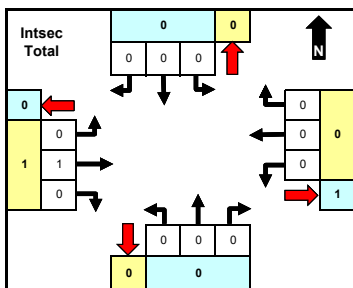
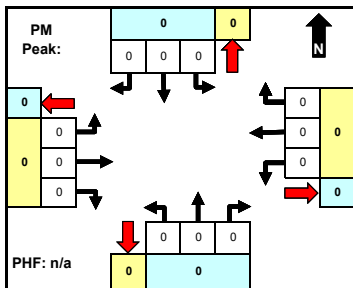
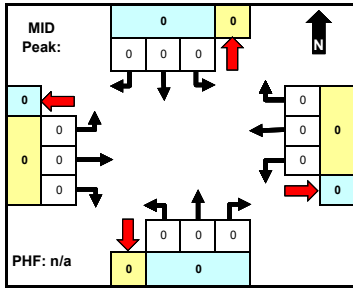
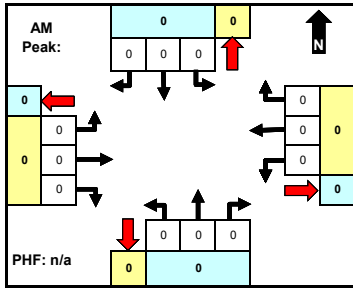

	North		East		South		West		Total
	App	Dep	App	Dep	App	Dep	App	Dep	
AM	0	0	0	0	0	0	0	0	0
MID	0	0	0	0	0	0	0	0	0
PM	0	0	0	0	0	0	0	0	0
Total	0	0	0	1	0	0	1	0	1

Comments

Unless shown otherwise, MID period defined as 10:00 AM - 2:00 PM. Peaks defined based on total intersection volume for all vehicle types.

Time	From North (SB)				From East (WB)				From South (NB)				From West (EB)				TOTAL
	LT	Thru	RT	U	LT	Thru	RT	U	LT	Thru	RT	U	LT	Thru	RT	U	
0:00																	0
0:15																	0
0:30																	0
0:45																	0
1:00																	0
1:15																	0
1:30																	0
1:45																	0
2:00																	0
2:15																	0
2:30																	0
2:45																	0
3:00																	0
3:15																	0
3:30																	0
3:45																	0
4:00																	0
4:15																	0
4:30																	0
4:45																	0
5:00																	0
5:15																	0
5:30																	0
5:45																	0
6:00																	0
6:15																	0
6:30	0	0	0	0	0	0	0	0	0	0	0	0	0	0	0	0	0
6:45	0	0	0	0	0	0	0	0	0	0	0	0	0	0	0	0	0
7:00	0	0	0	0	0	0	0	0	0	0	0	0	0	0	0	0	0
7:15	0	0	0	0	0	0	0	0	0	0	0	0	0	0	0	0	0
7:30	0	0	0	0	0	0	0	0	0	0	0	0	0	0	0	0	0
7:45	0	0	0	0	0	0	0	0	0	0	0	0	0	0	0	0	0
8:00	0	0	0	0	0	0	0	0	0	0	0	0	0	0	0	0	0
8:15	0	0	0	0	0	0	0	0	0	0	0	0	0	0	0	0	0
8:30																	0
8:45																	0
9:00																	0
9:15																	0
9:30																	0
9:45																	0
10:00																	0
10:15																	0
10:30																	0
10:45																	0
11:00	0	0	0	0	0	0	0	0	0	0	0	0	0	0	0	0	0
11:15	0	0	0	0	0	0	0	0	0	0	0	0	0	0	0	0	0
11:30	0	0	0	0	0	0	0	0	0	0	0	0	0	0	0	0	0
11:45	0	0	0	0	0	0	0	0	0	0	0	0	0	0	0	0	0
12:00	0	0	0	0	0	0	0	0	0	0	0	0	0	0	0	0	0
12:15	0	0	0	0	0	0	0	0	0	0	0	0	0	0	0	0	0
12:30	0	0	0	0	0	0	0	0	0	0	0	0	0	0	0	0	0
12:45	0	0	0	0	0	0	0	0	0	0	0	0	0	0	0	0	0
13:00																	0
13:15																	0
13:30																	0
13:45																	0
14:00																	0
14:15																	0
14:30																	0
14:45																	0
15:00																	0
15:15																	0
15:30																	0
15:45																	0
16:00	0	0	0	0	0	0	0	0	0	0	0	0	0	0	0	0	0
16:15	0	0	0	0	0	0	0	0	0	0	0	0	0	0	0	0	0
16:30	0	0	0	0	0	0	0	0	0	0	0	0	0	0	0	0	0
16:45	0	0	0	0	0	0	0	0	0	0	0	0	0	0	0	0	0
17:00	0	0	0	0	0	0	0	0	0	0	0	0	0	0	0	0	0
17:15	0	0	0	0	0	0	0	0	0	0	0	0	0	0	0	0	0
17:30	0	0	0	0	0	0	0	0	0	0	0	0	0	0	0	0	0
17:45	0	0	0	0	0	0	0	0	0	0	0	0	0	0	0	0	0
18:00	0	0	0	0	0	0	0	0	0	0	0	0	0	0	0	0	0
18:15																	0
18:30																	0
18:45																	0
19:00																	0
19:15																	0
19:30																	0
19:45																	0
20:00																	0
20:15																	0
20:30																	0
20:45																	0
21:00																	0
21:15																	0
21:30																	0
21:45																	0
22:00																	0
22:15																	0
22:30																	0
22:45																	0
23:00																	0
23:15																	0
23:30																	0
23:45																	0
Total	0	0	0	0	0	0	0	0	0	0	0	0	0	0	1	0	1
AM Peak Hr:																	7:15
Pk Vol	0	0	0	0	0	0	0	0	0	0	0	0	0	0	0	0	0
PHF	n/a	n/a	n/a	n/a	n/a	n/a	n/a	n/a	n/a	n/a	n/a	n/a	n/a	n/a	n/a	n/a	n/a
MID Peak Hr:																	12:00
Pk Vol	0	0	0	0	0	0	0	0	0	0	0	0	0	0	0	0	0
PHF	n/a	n/a	n/a	n/a	n/a	n/a	n/a	n/a	n/a	n/a	n/a	n/a	n/a	n/a	n/a	n/a	n/a
PM Peak Hr:																	16:45
Pk Vol	0	0	0	0	0	0	0	0	0	0	0	0	0	0	0	0	0
PHF	n/a	n/a	n/a	n/a	n/a	n/a	n/a	n/a	n/a	n/a	n/a	n/a	n/a	n/a	n/a	n/a	n/a

Intersection ID: 1805157
Count Date: 11/27/2018

N 7TH ST & ROSE LANE

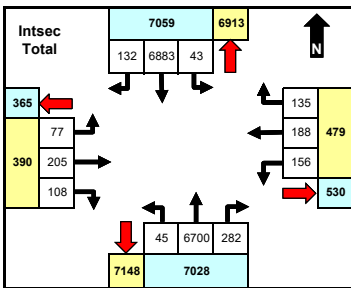
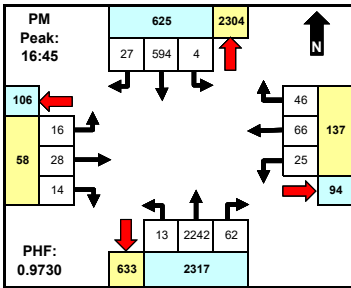
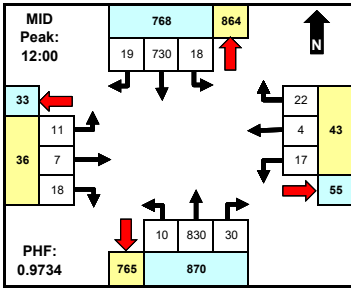
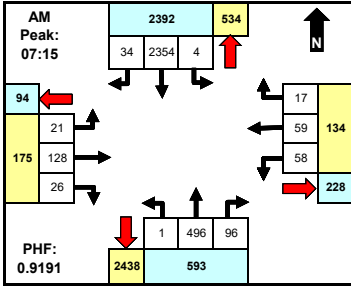

	North		East		South		West		Total
	App	Dep	App	Dep	App	Dep	App	Dep	
AM	2392	534	134	228	593	2438	175	94	3294
MID	768	864	43	55	870	765	36	33	1717
PM	625	2304	137	94	2317	633	58	106	3137
Total	7059	6913	479	530	7028	7148	390	365	###

Time	From North (SB)				From East (WB)				From South (NB)				From West (EB)				TOTAL
	LT	Thru	RT	U	LT	Thru	RT	U	LT	Thru	RT	U	LT	Thru	RT	U	

Time	N 7TH ST				ROSE LANE				N 7TH ST				ROSE LANE				INTSEC
	LT	Thru	RT	U	LT	Thru	RT	U	LT	Thru	RT	U	LT	Thru	RT	U	
0:00																	0
0:15																	0
0:30																	0
0:45																	0
1:00																	0
1:15																	0
1:30																	0
1:45																	0
2:00																	0
2:15																	0
2:30																	0
2:45																	0
3:00																	0
3:15																	0
3:30																	0
3:45																	0
4:00																	0
4:15																	0
4:30																	0
4:45																	0
5:00																	0
5:15																	0
5:30																	0
5:45																	0
6:00																	0
6:15																	0
6:30	0	416	1	0	2	2	2	0	0	79	0	0	1	2	2	0	507
6:45	0	520	1	0	2	0	3	0	0	90	1	0	0	0	3	0	623
7:00	0	566	5	0	6	1	1	0	1	100	19	0	1	11	3	0	716
7:15	1	618	12	0	11	7	4	0	0	123	38	0	5	31	2	0	852
7:30	2	583	12	0	22	29	8	0	0	131	37	0	7	57	8	0	896
7:45	0	602	7	0	16	13	5	0	0	127	13	0	8	25	8	0	824
8:00	1	551	3	0	9	10	0	0	0	115	8	0	1	15	8	0	722
8:15	1	400	2	0	5	3	0	0	0	107	5	0	0	5	6	0	534
8:30																	0
8:45																	0
9:00																	0
9:15																	0
9:30																	0
9:45																	0
10:00																	0
10:15																	0
10:30																	0
10:45																	0
11:00	0	191	3	0	7	2	2	0	1	166	2	0	2	0	5	0	381
11:15	4	180	4	0	7	2	7	0	1	188	4	0	1	0	4	0	402
11:30	4	155	4	0	2	2	5	0	4	209	3	0	1	1	4	0	394
11:45	2	200	1	0	4	2	3	0	4	197	6	1	5	0	5	0	430
12:00	4	182	5	1	6	0	6	0	2	197	4	0	6	3	2	0	418
12:15	3	188	2	0	4	1	5	0	1	201	8	0	2	1	4	0	420
12:30	5	183	5	0	5	2	6	0	3	212	11	0	2	0	7	0	441
12:45	6	177	7	0	2	1	5	0	4	220	7	0	1	3	5	0	438
13:00																	0
13:15																	0
13:30																	0
13:45																	0
14:00																	0
14:15																	0
14:30																	0
14:45																	0
15:00																	0
15:15																	0
15:30																	0
15:45																	0
16:00	1	130	7	0	7	12	7	0	2	460	11	0	8	8	3	0	656
16:15	2	125	9	0	1	11	7	0	1	541	13	0	0	4	3	0	717
16:30	1	161	8	0	4	8	4	0	4	537	13	0	8	5	6	0	759
16:45	1	150	7	0	9	12	10	0	2	540	16	0	2	3	0	0	752
17:00	1	171	5	0	4	16	11	0	2	562	18	0	4	10	2	0	806
17:15	1	131	10	0	6	16	12	0	3	587	19	0	3	5	9	0	802
17:30	1	142	5	0	6	22	13	0	6	553	9	0	7	10	3	0	777
17:45	2	161	7	0	9	14	9	0	3	458	17	0	2	3	4	0	689
18:00																	0
18:15																	0
18:30																	0
18:45																	0
19:00																	0
19:15																	0
19:30																	0
19:45																	0
20:00																	0
20:15																	0
20:30																	0
20:45																	0
21:00																	0
21:15																	0
21:30																	0
21:45																	0
22:00																	0
22:15																	0
22:30																	0
22:45																	0
23:00																	0
23:15																	0
23:30																	0
23:45																	0
Total	43	6883	132	1	156	188	135	0	45	6700	282	1	77	205	108	0	14956

Comments
Unless shown otherwise, MID period defined as 10:00 AM - 2:00 PM. Peaks defined based on total intersection volume for all vehicle types.

AM Peak Hr:	7:15																
Pk Vol	4	2354	34	0	58	59	17	0	1	496	96	0	21	128	26	0	3294
PHF	0.500	0.952	0.708	n/a	0.659	0.509	0.531	n/a	0.250	0.947	0.632	n/a	0.656	0.561	0.813	n/a	0.919
MID Peak Hr:	12:00																
Pk Vol	18	730	19	1	17	4	22	0	10	830	30	0	11	7	18	0	1717
PHF	0.750	0.971	0.679	0.250	0.708	0.500	0.917	n/a	0.625	0.943	0.682	n/a	0.458	0.583	0.643	n/a	0.973
PM Peak Hr:	16:45																
Pk Vol	4	594	27	0	25	66	46	0	13	2242	62	0	16	28	14	0	3137
PHF	1.000	0.868	0.675	n/a	0.694	0.750	0.885	n/a	0.542	0.955	0.816	n/a	0.571	0.700	0.389	n/a	0.973



Intersection ID: 1805157
Count Date: 11/27/2018

N 7TH ST & ROSE LANE

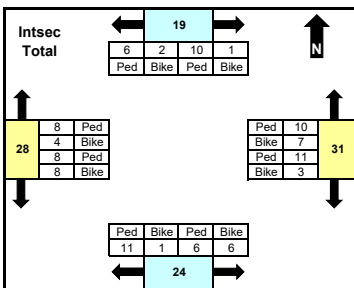
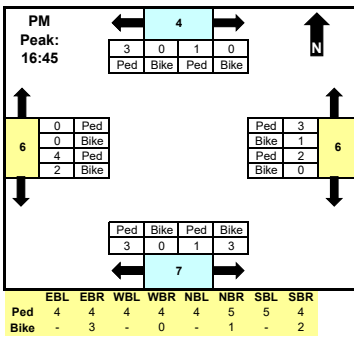
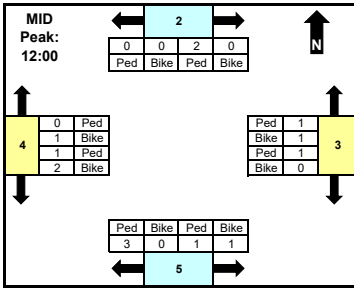
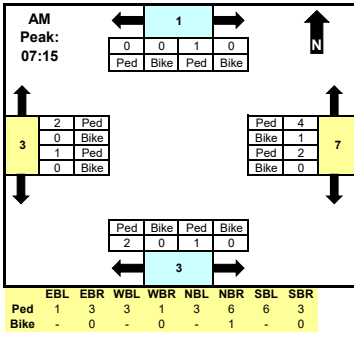

	North		East		South		West		Total
	CW	CCW	CW	CCW	CW	CCW	CW	CCW	
AM	1	0	2	5	2	1	2	1	14
MID	2	0	1	2	3	2	1	3	14
PM	1	3	2	4	3	4	0	6	23
Total	11	8	14	17	12	12	12	16	102

CW = Clockwise
CCW = Counter-clockwise

Comments

Unless shown otherwise, MID period defined as 10:00 AM - 2:00 PM. Crosswalk peaks defined based on total intersection volume for all vehicle types.

Time	North Leg		East Leg		South Leg		West Leg		INTSEC	TOTAL					
	CW	CCW	CW	CCW	CW	CCW	CW	CCW							
0:00										0					
0:15										0					
0:30										0					
0:45										0					
1:00										0					
1:15										0					
1:30										0					
1:45										0					
2:00										0					
2:15										0					
2:30										0					
2:45										0					
3:00										0					
3:15										0					
3:30										0					
3:45										0					
4:00										0					
4:15										0					
4:30										0					
4:45										0					
5:00										0					
5:15										0					
5:30										0					
5:45										0					
6:00										0					
6:15										0					
6:30	0	0	0	0	0	0	0	0	1	0					
6:45	2	0	0	0	1	0	0	1	2	0					
7:00	0	0	0	0	0	0	0	0	0	2					
7:15	0	0	0	0	0	0	1	0	0	3					
7:30	0	0	0	0	1	0	0	1	0	4					
7:45	0	0	0	0	1	0	0	1	0	4					
8:00	1	0	0	0	1	0	0	0	1	7					
8:15	1	0	0	0	0	0	0	0	1	3					
8:30										0					
8:45										0					
9:00										0					
9:15										0					
9:30										0					
9:45										0					
10:00										0					
10:15										0					
10:30										0					
10:45										0					
11:00	0	1	3	0	2	1	0	0	0	10					
11:15	0	0	0	0	0	0	1	0	0	1					
11:30	0	0	0	0	0	0	2	0	0	5					
11:45	0	0	0	1	0	0	1	0	0	3					
12:00	0	0	0	0	0	0	1	2	0	4					
12:15	0	0	0	0	0	0	0	0	0	2					
12:30	0	0	0	0	0	1	0	0	0	1					
12:45	2	0	0	0	1	0	0	1	0	5					
13:00										0					
13:15										0					
13:30										0					
13:45										0					
14:00										0					
14:15										0					
14:30										0					
14:45										0					
15:00										0					
15:15										0					
15:30										0					
15:45										0					
16:00	2	0	0	0	0	1	0	0	2	6					
16:15	0	0	0	1	0	1	0	0	0	4					
16:30	1	0	0	0	1	0	0	0	0	3					
16:45	1	0	1	0	1	0	1	0	3	11					
17:00	0	0	1	0	1	0	1	0	0	7					
17:15	0	0	0	0	0	0	0	0	0	0					
17:30	0	0	1	0	0	1	1	0	1	5					
17:45	0	0	0	0	2	0	0	0	1	3					
18:00										0					
18:15										0					
18:30										0					
18:45										0					
19:00										0					
19:15										0					
19:30										0					
19:45										0					
20:00										0					
20:15										0					
20:30										0					
20:45										0					
21:00										0					
21:15										0					
21:30										0					
21:45										0					
22:00										0					
22:15										0					
22:30										0					
22:45										0					
23:00										0					
23:15										0					
23:30										0					
23:45										0					
Total	10	1	6	2	11	3	10	7	11	6	8	4	8	8	102
AM Peak Hr:															7:15
PK Vol	1	0	0	0	2	0	4	1	2	0	1	0	2	0	14
MID Peak Hr:															12:00
PK Vol	2	0	0	0	1	0	1	1	3	0	1	1	0	1	14
PM Peak Hr:															16:45
PK Vol	1	0	3	0	2	0	3	1	3	0	1	3	0	4	23

Intersection ID: 1805157
Count Date: 11/27/2018

N 7TH ST & ROSE LANE

From North (SB) From East (WB) From South (NB) From West (EB)
N 7TH ST ROSE LANE N 7TH ST ROSE LANE INTSEC

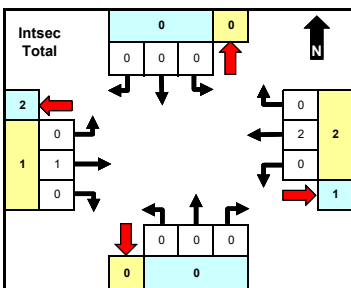
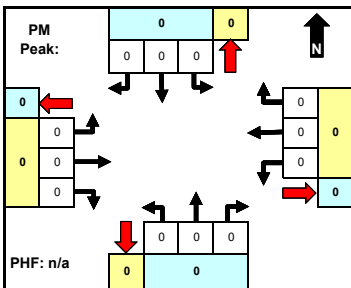
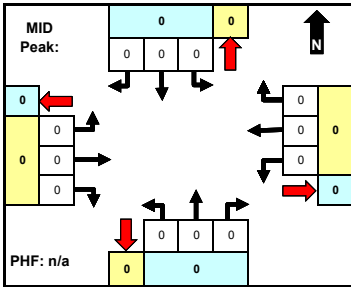
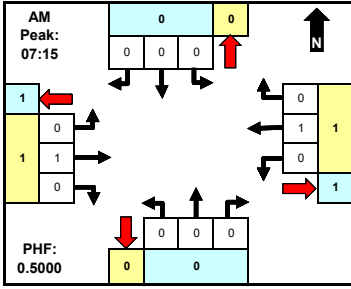

	North		East		South		West		Total
	App	Dep	App	Dep	App	Dep	App	Dep	
AM	0	0	1	1	0	0	1	1	2
MID	0	0	0	0	0	0	0	0	0
PM	0	0	0	0	0	0	0	0	0
Total	0	0	2	1	0	0	1	2	3

Comments

Unless shown otherwise, MID period defined as 10:00 AM - 2:00 PM. Peaks defined based on total intersection volume for all vehicle types.

Time	From North (SB)				From East (WB)				From South (NB)				From West (EB)				TOTAL
	LT	Thru	RT	U	LT	Thru	RT	U	LT	Thru	RT	U	LT	Thru	RT	U	
0:00																	0
0:15																	0
0:30																	0
0:45																	0
1:00																	0
1:15																	0
1:30																	0
1:45																	0
2:00																	0
2:15																	0
2:30																	0
2:45																	0
3:00																	0
3:15																	0
3:30																	0
3:45																	0
4:00																	0
4:15																	0
4:30																	0
4:45																	0
5:00																	0
5:15																	0
5:30																	0
5:45																	0
6:00																	0
6:15																	0
6:30	0	0	0	0	0	0	0	0	0	0	0	0	0	0	0	0	0
6:45	0	0	0	0	0	0	1	0	0	0	0	0	0	0	0	0	1
7:00	0	0	0	0	0	0	0	0	0	0	0	0	0	0	0	0	0
7:15	0	0	0	0	0	0	0	0	0	0	0	0	0	0	0	0	0
7:30	0	0	0	0	0	0	0	0	0	0	0	0	0	0	0	0	0
7:45	0	0	0	0	0	0	1	0	0	0	0	0	0	0	0	0	1
8:00	0	0	0	0	0	0	0	0	0	0	0	0	0	0	1	0	1
8:15	0	0	0	0	0	0	0	0	0	0	0	0	0	0	0	0	0
8:30																	0
8:45																	0
9:00																	0
9:15																	0
9:30																	0
9:45																	0
10:00																	0
10:15																	0
10:30																	0
10:45																	0
11:00	0	0	0	0	0	0	0	0	0	0	0	0	0	0	0	0	0
11:15	0	0	0	0	0	0	0	0	0	0	0	0	0	0	0	0	0
11:30	0	0	0	0	0	0	0	0	0	0	0	0	0	0	0	0	0
11:45	0	0	0	0	0	0	0	0	0	0	0	0	0	0	0	0	0
12:00	0	0	0	0	0	0	0	0	0	0	0	0	0	0	0	0	0
12:15	0	0	0	0	0	0	0	0	0	0	0	0	0	0	0	0	0
12:30	0	0	0	0	0	0	0	0	0	0	0	0	0	0	0	0	0
12:45	0	0	0	0	0	0	0	0	0	0	0	0	0	0	0	0	0
13:00																	0
13:15																	0
13:30																	0
13:45																	0
14:00																	0
14:15																	0
14:30																	0
14:45																	0
15:00																	0
15:15																	0
15:30																	0
15:45																	0
16:00	0	0	0	0	0	0	0	0	0	0	0	0	0	0	0	0	0
16:15	0	0	0	0	0	0	0	0	0	0	0	0	0	0	0	0	0
16:30	0	0	0	0	0	0	0	0	0	0	0	0	0	0	0	0	0
16:45	0	0	0	0	0	0	0	0	0	0	0	0	0	0	0	0	0
17:00	0	0	0	0	0	0	0	0	0	0	0	0	0	0	0	0	0
17:15	0	0	0	0	0	0	0	0	0	0	0	0	0	0	0	0	0
17:30	0	0	0	0	0	0	0	0	0	0	0	0	0	0	0	0	0
17:45	0	0	0	0	0	0	0	0	0	0	0	0	0	0	0	0	0
18:00	0	0	0	0	0	0	0	0	0	0	0	0	0	0	0	0	0
18:15																	0
18:30																	0
18:45																	0
19:00																	0
19:15																	0
19:30																	0
19:45																	0
20:00																	0
20:15																	0
20:30																	0
20:45																	0
21:00																	0
21:15																	0
21:30																	0
21:45																	0
22:00																	0
22:15																	0
22:30																	0
22:45																	0
23:00																	0
23:15																	0
23:30																	0
23:45																	0
Total	0	0	0	0	0	0	2	0	0	0	0	0	0	0	1	0	3
AM Peak Hr:																	7:15
Pk Vol	0	0	0	0	0	1	0	0	0	0	0	0	0	0	1	0	2
PHF	n/a	n/a	n/a	n/a	n/a	0.250	n/a	n/a	n/a	n/a	n/a	n/a	n/a	n/a	0.250	n/a	0.500
MID Peak Hr:																	12:00
Pk Vol	0	0	0	0	0	0	0	0	0	0	0	0	0	0	0	0	0
PHF	n/a	n/a	n/a	n/a	n/a	n/a	n/a	n/a	n/a	n/a	n/a	n/a	n/a	n/a	n/a	n/a	n/a
PM Peak Hr:																	16:45
Pk Vol	0	0	0	0	0	0	0	0	0	0	0	0	0	0	0	0	0
PHF	n/a	n/a	n/a	n/a	n/a	n/a	n/a	n/a	n/a	n/a	n/a	n/a	n/a	n/a	n/a	n/a	n/a

Intersection ID: 1805138
Count Date: 11/29/2018

N 7TH ST & E MARYLAND AVE

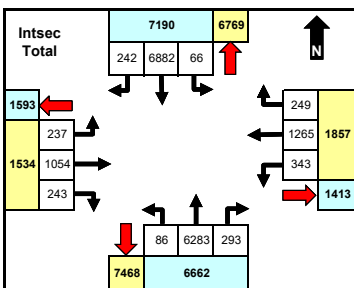
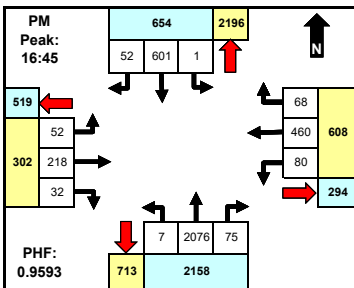
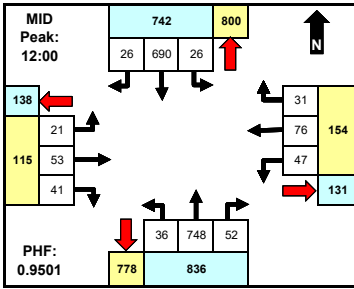
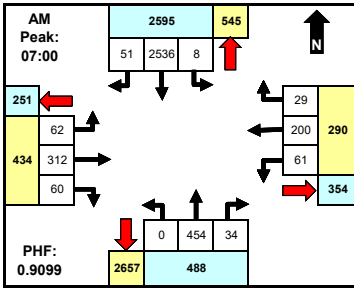

	North		East		South		West		Total
	App	Dep	App	Dep	App	Dep	App	Dep	
AM	2595	545	290	354	488	2657	434	251	3807
MID	742	800	154	131	836	778	115	138	1847
PM	654	2196	608	294	2158	713	302	519	3722
Total	7190	6769	1857	1413	6662	7468	1534	1593	17243

Comments

Unless shown otherwise, MID period defined as 10:00 AM - 2:00 PM. Peaks defined based on total intersection volume for all vehicle types.

Time	From North (SB)				From East (WB)				From South (NB)				From West (EB)				INTSEC	TOTAL
	N 7TH ST		E MARYLAND AVE		N 7TH ST		E MARYLAND AVE		N 7TH ST		E MARYLAND AVE		N 7TH ST		E MARYLAND AVE			
	LT	Thru	RT	U	LT	Thru	RT	U	LT	Thru	RT	U	LT	Thru	RT	U		
0:00																	0	
0:15																	0	
0:30																	0	
0:45																	0	
1:00																	0	
1:15																	0	
1:30																	0	
1:45																	0	
2:00																	0	
2:15																	0	
2:30																	0	
2:45																	0	
3:00																	0	
3:15																	0	
3:30																	0	
3:45																	0	
4:00																	0	
4:15																	0	
4:30																	0	
4:45																	0	
5:00																	0	
5:15																	0	
5:30																	0	
5:45																	0	
6:00																	0	
6:15																	0	
6:30	0	425	4	0	11	14	2	0	0	52	8	0	5	31	2	0	554	
6:45	0	544	4	0	12	15	3	0	0	76	7	0	4	37	11	0	713	
7:00	1	604	7	0	10	23	4	0	0	90	5	0	7	52	13	0	816	
7:15	2	686	7	0	12	30	4	0	0	124	12	0	11	82	6	0	976	
7:30	0	605	15	0	15	69	10	0	0	109	7	0	19	97	23	0	969	
7:45	5	641	22	0	24	78	11	0	0	131	10	0	25	81	18	0	1046	
8:00	1	414	16	0	10	48	8	0	1	103	6	0	14	81	16	0	718	
8:15	1	418	17	0	12	28	7	0	0	131	7	0	14	72	15	0	722	
8:30																	0	
8:45																	0	
9:00																	0	
9:15																	0	
9:30																	0	
9:45																	0	
10:00																	0	
10:15																	0	
10:30																	0	
10:45																	0	
11:00	5	152	6	0	7	11	6	0	7	194	12	0	8	17	11	0	436	
11:15	9	161	4	0	13	10	6	0	6	178	10	0	6	18	11	0	432	
11:30	6	211	5	0	13	11	7	0	8	154	7	0	10	22	11	0	465	
11:45	8	191	6	0	13	20	11	0	6	175	3	0	3	13	9	0	458	
12:00	5	168	6	0	8	17	7	0	5	161	15	0	7	15	9	0	423	
12:15	3	172	7	0	13	19	10	0	5	188	16	0	3	13	10	0	459	
12:30	5	174	9	0	16	22	6	0	15	197	11	0	7	12	12	0	486	
12:45	13	176	4	0	10	18	8	0	11	202	10	0	4	13	10	0	479	
13:00																	0	
13:15																	0	
13:30																	0	
13:45																	0	
14:00																	0	
14:15																	0	
14:30																	0	
14:45																	0	
15:00																	0	
15:15																	0	
15:30																	0	
15:45																	0	
16:00	1	131	16	0	13	87	15	0	2	506	17	0	6	38	8	0	840	
16:15	0	115	8	0	15	84	24	0	1	458	20	0	11	56	7	0	799	
16:30	0	138	12	0	13	97	15	0	8	519	16	0	8	31	4	0	861	
16:45	1	161	10	0	29	113	20	0	1	481	16	0	16	49	8	0	905	
17:00	0	149	15	0	19	115	21	0	1	515	19	0	14	54	10	0	932	
17:15	0	157	13	0	15	120	14	0	2	548	23	0	11	60	7	0	970	
17:30	0	134	14	0	17	112	13	0	3	532	17	0	11	55	7	0	915	
17:45	0	155	15	0	23	104	17	0	4	459	19	0	13	55	5	0	869	
18:00																	0	
18:15																	0	
18:30																	0	
18:45																	0	
19:00																	0	
19:15																	0	
19:30																	0	
19:45																	0	
20:00																	0	
20:15																	0	
20:30																	0	
20:45																	0	
21:00																	0	
21:15																	0	
21:30																	0	
21:45																	0	
22:00																	0	
22:15																	0	
22:30																	0	
22:45																	0	
23:00																	0	
23:15																	0	
23:30																	0	
23:45																	0	
Total	66	6882	242	0	343	1265	249	0	86	6283	293	0	237	1054	243	0	17243	
AM Peak Hr:																	7:00	
PK Vol	8	2536	51	0	61	200	29	0	0	454	34	0	62	312	60	0	3807	
PHF	0.400	0.924	0.580	n/a	0.635	0.641	0.659	n/a	n/a	0.866	0.708	n/a	0.620	0.804	0.652	n/a	0.910	
MID Peak Hr:																	12:00	
PK Vol	26	690	26	0	47	76	31	0	36	748	62	0	21	53	41	0	1347	
PHF	0.500	0.980	0.722	n/a	0.734	0.864	0.775	n/a	0.600	0.926	0.813	n/a	0.750	0.883	0.854	n/a	0.950	
PM Peak Hr:																	16:45	
PK Vol	1	601	52	0	80	460	68	0	7	2076	76	0	52	218	32	0	3722	
PHF	0.250	0.333	0.867	n/a	0.690	0.958	0.810	n/a	0.583	0.947	0.815	n/a	0.813	0.908	0.800	n/a	0.959	

Intersection ID: 1805138
Count Date: 11/29/2018

N 7TH ST & E MARYLAND AVE

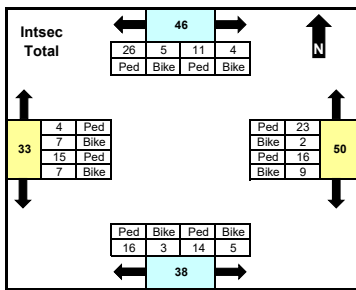
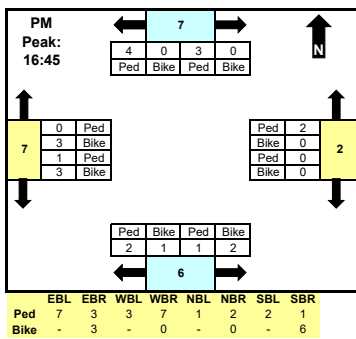
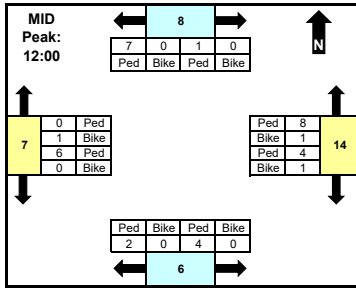
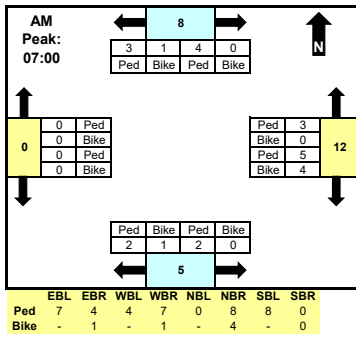

	North		East		South		West		Total
	CW	CCW	CW	CCW	CW	CCW	CW	CCW	
AM	4	4	9	3	3	2	0	0	25
MID	1	7	5	9	2	4	1	6	35
PM	3	4	0	2	3	3	3	4	22
Total	15	31	25	25	19	19	11	22	167

CW = Clockwise
CCW = Counter-clockwise

Comments
Unless shown otherwise, MID period defined as 10:00 AM - 2:00 PM. Crosswalk peaks defined based on total intersection volume for all vehicle types.

Time	North Leg		East Leg		South Leg		West Leg		INTSEC	TOTAL							
	CW	CCW	CW	CCW	CW	CCW	CW	CCW									
0:00										0							
0:15										0							
0:30										0							
0:45										0							
1:00										0							
1:15										0							
1:30										0							
1:45										0							
2:00										0							
2:15										0							
2:30										0							
2:45										0							
3:00										0							
3:15										0							
3:30										0							
3:45										0							
4:00										0							
4:15										0							
4:30										0							
4:45										0							
5:00										0							
5:15										0							
5:30										0							
5:45										0							
6:00										0							
6:15										0							
6:30	0	0	0	0	0	0	6	0	3	0	15						
6:45	0	0	0	0	2	0	1	0	0	0	4						
7:00	1	0	1	0	2	0	0	0	0	0	7						
7:15	1	0	2	0	1	2	0	0	1	0	7						
7:30	0	0	0	1	2	0	0	0	1	0	4						
7:45	2	0	1	1	0	3	0	0	0	0	7						
8:00	2	2	1	2	1	2	1	0	0	0	13						
8:15	0	0	4	2	0	1	3	0	0	1	12						
8:30											0						
8:45											0						
9:00											0						
9:15											0						
9:30											0						
9:45											0						
10:00											0						
10:15											0						
10:30											0						
10:45											0						
11:00	0	0	0	0	0	0	1	0	0	0	1						
11:15	0	1	1	0	0	0	1	0	0	0	5						
11:30	0	0	0	0	0	0	0	1	0	0	1						
11:45	0	0	0	0	0	1	0	0	0	0	2						
12:00	1	0	2	0	1	0	3	1	1	0	14						
12:15	0	0	5	0	1	0	4	0	0	0	11						
12:30	0	0	0	0	2	0	0	1	0	0	7						
12:45	0	0	0	0	1	1	0	0	0	0	3						
13:00											0						
13:15											0						
13:30											0						
13:45											0						
14:00											0						
14:15											0						
14:30											0						
14:45											0						
15:00											0						
15:15											0						
15:30											0						
15:45											0						
16:00	1	0	4	0	2	0	2	0	1	1	13						
16:15	0	0	0	0	1	0	1	0	0	2	7						
16:30	0	1	2	0	1	0	0	0	1	0	11						
16:45	0	0	3	0	0	2	0	0	1	0	8						
17:00	0	0	0	0	0	0	0	1	0	0	5						
17:15	0	0	1	0	0	0	0	1	0	0	5						
17:30	3	0	0	0	0	0	0	0	0	0	4						
17:45	0	0	0	0	0	0	0	0	0	0	0						
18:00											0						
18:15											0						
18:30											0						
18:45											0						
19:00											0						
19:15											0						
19:30											0						
19:45											0						
20:00											0						
20:15											0						
20:30											0						
20:45											0						
21:00											0						
21:15											0						
21:30											0						
21:45											0						
22:00											0						
22:15											0						
22:30											0						
22:45											0						
23:00											0						
23:15											0						
23:30											0						
23:45											0						
Total	11	4	26	5	16	9	23	2	16	3	14	5	4	7	15	7	167
AM Peak Hr:																	7:00
PK Vol	4	0	3	1	5	4	3	0	2	1	2	0	0	0	0	0	25
MID Peak Hr:																	12:00
PK Vol	1	0	7	0	4	1	8	1	2	0	4	0	0	1	6	0	35
PM Peak Hr:																	16:45
PK Vol	3	0	4	0	0	0	2	0	2	1	1	2	0	3	1	3	22

Intersection ID: 1805138
Count Date: 11/29/2018

N 7TH ST & E MARYLAND AVE

From North (SB) From East (WB) From South (NB) From West (EB)
N 7TH ST E MARYLAND AVE N 7TH ST E MARYLAND AVE INTSEC

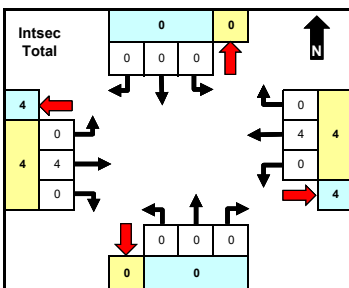
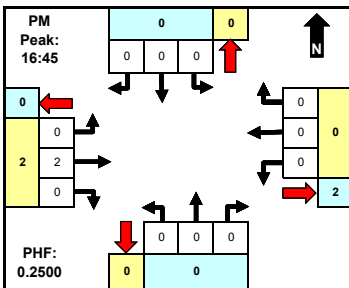
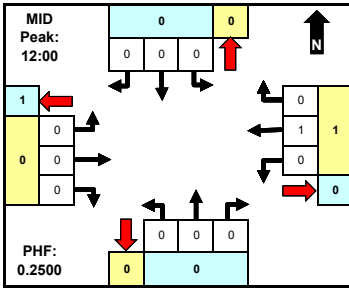
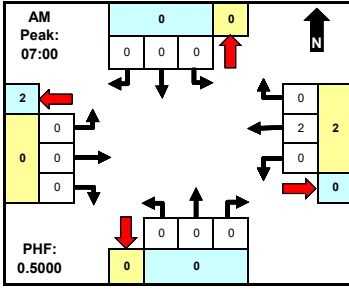

	North		East		South		West		Total
	App	Dep	App	Dep	App	Dep	App	Dep	
AM	0	0	2	0	0	0	0	2	2
MID	0	0	1	0	0	0	0	1	1
PM	0	0	0	2	0	0	2	0	2
Total	0	0	4	4	0	0	4	4	8

Comments

Unless shown otherwise, MID period defined as 10:00 AM - 2:00 PM. Peaks defined based on total intersection volume for all vehicle types.

Time	From North (SB)				From East (WB)				From South (NB)				From West (EB)				TOTAL
	LT	Thru	RT	U	LT	Thru	RT	U	LT	Thru	RT	U	LT	Thru	RT	U	
0:00																	0
0:15																	0
0:30																	0
0:45																	0
1:00																	0
1:15																	0
1:30																	0
1:45																	0
2:00																	0
2:15																	0
2:30																	0
2:45																	0
3:00																	0
3:15																	0
3:30																	0
3:45																	0
4:00																	0
4:15																	0
4:30																	0
4:45																	0
5:00																	0
5:15																	0
5:30																	0
5:45																	0
6:00																	0
6:15																	0
6:30	0	0	0	0	0	0	0	0	0	0	0	0	0	0	0	0	
6:45	0	0	0	0	0	0	0	0	0	0	0	0	0	0	0	0	
7:00	0	0	0	0	0	1	0	0	0	0	0	0	0	0	0	1	
7:15	0	0	0	0	0	0	0	0	0	0	0	0	0	0	0	0	
7:30	0	0	0	0	0	1	0	0	0	0	0	0	0	0	0	1	
7:45	0	0	0	0	0	0	0	0	0	0	0	0	0	0	0	0	
8:00	0	0	0	0	0	0	0	0	0	0	0	0	0	0	0	0	
8:15	0	0	0	0	0	0	0	0	0	0	0	0	0	0	0	0	
8:30																	0
8:45																	0
9:00																	0
9:15																	0
9:30																	0
9:45																	0
10:00																	0
10:15																	0
10:30																	0
10:45																	0
11:00	0	0	0	0	0	0	0	0	0	0	0	0	0	0	0	0	
11:15	0	0	0	0	0	0	0	0	0	0	0	0	0	0	0	0	
11:30	0	0	0	0	0	0	0	0	0	0	0	0	0	0	0	0	
11:45	0	0	0	0	0	0	0	0	0	0	0	0	0	0	0	0	
12:00	0	0	0	0	0	0	0	0	0	0	0	0	0	0	0	0	
12:15	0	0	0	0	0	0	0	0	0	0	0	0	0	0	0	0	
12:30	0	0	0	0	0	1	0	0	0	0	0	0	0	0	0	1	
12:45	0	0	0	0	0	0	0	0	0	0	0	0	0	0	0	0	
13:00																	0
13:15																	0
13:30																	0
13:45																	0
14:00																	0
14:15																	0
14:30																	0
14:45																	0
15:00																	0
15:15																	0
15:30																	0
15:45																	0
16:00	0	0	0	0	0	1	0	0	0	0	0	0	0	0	0	1	
16:15	0	0	0	0	0	0	0	0	0	0	0	0	0	0	0	0	
16:30	0	0	0	0	0	0	0	0	0	0	0	0	0	0	0	0	
16:45	0	0	0	0	0	0	0	0	0	0	0	0	0	0	0	0	
17:00	0	0	0	0	0	0	0	0	0	0	0	0	0	0	0	0	
17:15	0	0	0	0	0	0	0	0	0	0	0	0	0	0	0	0	
17:30	0	0	0	0	0	0	0	0	0	0	0	0	0	0	0	0	
17:45	0	0	0	0	0	0	0	0	0	0	0	0	0	0	0	0	
18:00	0	0	0	0	0	0	0	0	0	0	0	0	0	0	0	0	
18:15																	0
18:30																	0
18:45																	0
19:00																	0
19:15																	0
19:30																	0
19:45																	0
20:00																	0
20:15																	0
20:30																	0
20:45																	0
21:00																	0
21:15																	0
21:30																	0
21:45																	0
22:00																	0
22:15																	0
22:30																	0
22:45																	0
23:00																	0
23:15																	0
23:30																	0
23:45																	0
Total	0	0	0	0	0	4	4	0	0	0	0	0	0	4	0	0	8
AM Peak Hr:																	7:00
Pk Vol	0	0	0	0	0	2	0	0	0	0	0	0	0	0	0	0	2
PHF	n/a	n/a	n/a	n/a	n/a	0.500	n/a	n/a	n/a	n/a	n/a	n/a	n/a	n/a	n/a	n/a	0.500
MID Peak Hr:																	12:00
Pk Vol	0	0	0	0	0	1	0	0	0	0	0	0	0	0	0	0	1
PHF	n/a	n/a	n/a	n/a	n/a	0.250	n/a	n/a	n/a	n/a	n/a	n/a	n/a	n/a	n/a	n/a	0.250
PM Peak Hr:																	16:45
Pk Vol	0	0	0	0	0	0	0	0	0	0	0	0	0	2	0	0	2
PHF	n/a	n/a	n/a	n/a	n/a	n/a	n/a	n/a	n/a	n/a	n/a	n/a	n/a	0.250	n/a	n/a	0.250

Intersection ID: 1805139
Count Date: 11/29/2018

N 7TH ST & E GLENDALE AVE

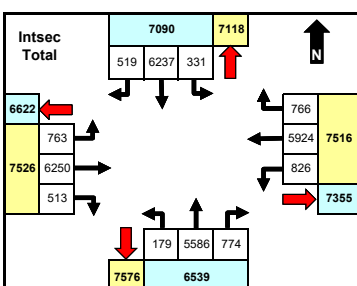
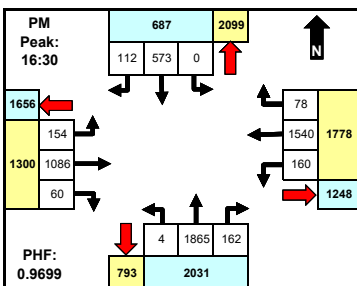
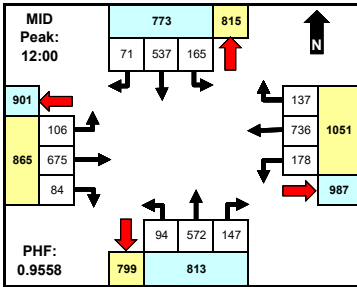
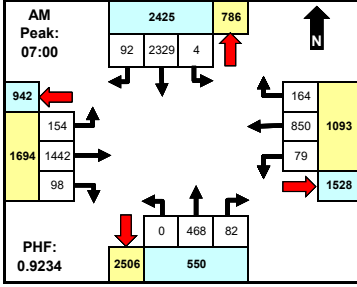

	North		East		South		West		Total
	App	Dep	App	Dep	App	Dep	App	Dep	
AM	2425	786	1093	1528	550	2506	1694	942	5762
MID	773	815	1051	987	813	799	865	901	3502
PM	687	2099	1778	1248	2031	793	1300	1656	5796
Total	7090	7118	7516	7355	6539	7576	7526	6622	28671

Time	From North (SB)				From East (WB)				From South (NB)				From West (EB)				INTSEC	TOTAL
	N 7TH ST		E GLENDALE AVE		N 7TH ST		E GLENDALE AVE		N 7TH ST		E GLENDALE AVE		N 7TH ST		E GLENDALE AVE			
	LT	Thru	RT	U	LT	Thru	RT	U	LT	Thru	RT	U	LT	Thru	RT	U		
0:00																	0	
0:15																	0	
0:30																	0	
0:45																	0	
1:00																	0	
1:15																	0	
1:30																	0	
1:45																	0	
2:00																	0	
2:15																	0	
2:30																	0	
2:45																	0	
3:00																	0	
3:15																	0	
3:30																	0	
3:45																	0	
4:00																	0	
4:15																	0	
4:30																	0	
4:45																	0	
5:00																	0	
5:15																	0	
5:30																	0	
5:45																	0	
6:00																	0	
6:15																	0	
6:30	9	384	17	0	14	132	31	0	0	52	10	0	6	361	17	0	1033	
6:45	3	493	16	0	17	142	48	0	0	68	12	0	26	331	26	0	1182	
7:00	1	564	24	0	11	157	39	0	0	83	18	0	23	359	24	0	1303	
7:15	2	550	18	0	19	180	33	0	0	122	16	0	44	371	24	0	1379	
7:30	0	604	24	0	24	288	48	0	0	133	19	0	42	357	21	0	1560	
7:45	1	611	26	0	25	225	44	0	0	130	29	0	45	355	29	0	1520	
8:00	2	477	23	0	25	207	29	0	1	94	28	0	37	299	23	0	1245	
8:15	2	386	27	0	14	151	36	0	0	128	27	0	34	301	29	0	1135	
8:30																	0	
8:45																	0	
9:00																	0	
9:15																	0	
9:30																	0	
9:45																	0	
10:00																	0	
10:15																	0	
10:30																	0	
10:45																	0	
11:00	32	138	18	0	38	145	30	0	22	138	42	0	29	178	13	0	823	
11:15	39	128	17	0	37	169	36	0	23	137	33	0	22	207	28	0	876	
11:30	38	153	15	0	33	172	48	0	13	133	42	0	14	159	22	0	842	
11:45	37	159	18	0	42	186	31	0	17	147	32	0	31	179	28	0	907	
12:00	42	122	20	0	41	199	31	0	21	117	36	0	31	159	20	0	839	
12:15	36	134	16	0	49	182	38	0	26	146	36	0	23	171	21	0	878	
12:30	34	133	22	0	45	187	38	0	23	145	31	0	21	167	23	0	869	
12:45	53	148	13	0	43	168	30	0	24	164	44	0	31	178	20	0	916	
13:00																	0	
13:15																	0	
13:30																	0	
13:45																	0	
14:00																	0	
14:15																	0	
14:30																	0	
14:45																	0	
15:00																	0	
15:15																	0	
15:30																	0	
15:45																	0	
16:00	0	120	27	0	31	399	25	0	1	409	38	0	35	247	15	0	1347	
16:15	0	107	27	0	47	370	17	0	0	449	45	0	42	263	19	0	1386	
16:30	0	140	27	0	32	400	18	0	1	445	35	0	45	253	12	0	1408	
16:45	0	140	25	2	44	385	21	0	1	477	41	0	36	274	15	0	1461	
17:00	0	133	30	0	36	407	17	0	0	451	44	0	30	268	17	0	1433	
17:15	0	160	30	0	48	348	22	0	2	492	42	0	43	291	16	0	1494	
17:30	0	127	11	1	50	371	26	0	3	445	39	0	37	271	24	0	1405	
17:45	0	126	28	0	61	354	30	0	1	481	35	0	36	251	27	0	1430	
18:00																	0	
18:15																	0	
18:30																	0	
18:45																	0	
19:00																	0	
19:15																	0	
19:30																	0	
19:45																	0	
20:00																	0	
20:15																	0	
20:30																	0	
20:45																	0	
21:00																	0	
21:15																	0	
21:30																	0	
21:45																	0	
22:00																	0	
22:15																	0	
22:30																	0	
22:45																	0	
23:00																	0	
23:15																	0	
23:30																	0	
23:45																	0	
Total	331	6237	519	3	826	5924	766	0	179	5586	774	0	763	6250	513	0	28671	

Comments
Unless shown otherwise, MID period defined as 10:00 AM - 2:00 PM. Peaks defined based on total intersection volume for all vehicle types.

Intersection ID: 1805139
Count Date: 11/29/2018

N 7TH ST & E GLENDALE AVE

From North (SB) From East (WB) From South (NB) From West (EB)
N 7TH ST E GLENDALE AVE N 7TH ST E GLENDALE AVE INTSEC

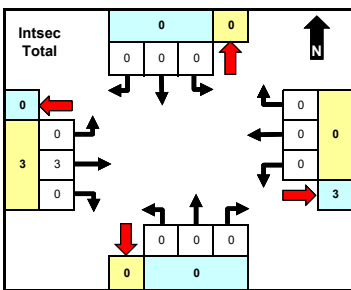
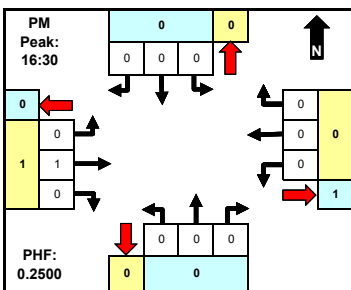
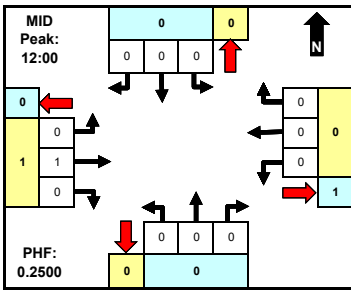
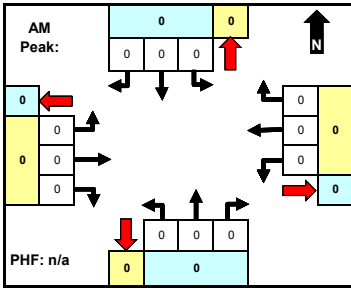

	North		East		South		West		Total
	App	Dep	App	Dep	App	Dep	App	Dep	
AM	0	0	0	0	0	0	0	0	0
MID	0	0	0	1	0	0	1	0	1
PM	0	0	0	1	0	0	1	0	1
Total	0	0	0	3	0	0	3	0	3

Comments

Unless shown otherwise, MID period defined as 10:00 AM - 2:00 PM. Peaks defined based on total intersection volume for all vehicle types.

Time	From North (SB)				From East (WB)				From South (NB)				From West (EB)				TOTAL
	LT	Thru	RT	U	LT	Thru	RT	U	LT	Thru	RT	U	LT	Thru	RT	U	
0:00																	0
0:15																	0
0:30																	0
0:45																	0
1:00																	0
1:15																	0
1:30																	0
1:45																	0
2:00																	0
2:15																	0
2:30																	0
2:45																	0
3:00																	0
3:15																	0
3:30																	0
3:45																	0
4:00																	0
4:15																	0
4:30																	0
4:45																	0
5:00																	0
5:15																	0
5:30																	0
5:45																	0
6:00																	0
6:15																	0
6:30	0	0	0	0	0	0	0	0	0	0	0	0	0	0	0	0	0
6:45	0	0	0	0	0	0	0	0	0	0	0	0	0	0	0	0	0
7:00	0	0	0	0	0	0	0	0	0	0	0	0	0	0	0	0	0
7:15	0	0	0	0	0	0	0	0	0	0	0	0	0	0	0	0	0
7:30	0	0	0	0	0	0	0	0	0	0	0	0	0	0	0	0	0
7:45	0	0	0	0	0	0	0	0	0	0	0	0	0	0	0	0	0
8:00	0	0	0	0	0	0	0	0	0	0	0	0	0	0	0	0	0
8:15	0	0	0	0	0	0	0	0	0	0	0	0	0	0	0	0	0
8:30																	0
8:45																	0
9:00																	0
9:15																	0
9:30																	0
9:45																	0
10:00																	0
10:15																	0
10:30																	0
10:45																	0
11:00	0	0	0	0	0	0	0	0	0	0	0	0	0	0	0	0	0
11:15	0	0	0	0	0	0	0	0	0	0	0	0	0	0	0	0	0
11:30	0	0	0	0	0	0	0	0	0	0	0	0	0	0	0	0	0
11:45	0	0	0	0	0	0	0	0	0	0	0	0	0	0	0	0	0
12:00	0	0	0	0	0	0	0	0	0	0	0	0	0	0	1	0	1
12:15	0	0	0	0	0	0	0	0	0	0	0	0	0	0	0	0	0
12:30	0	0	0	0	0	0	0	0	0	0	0	0	0	0	0	0	0
12:45	0	0	0	0	0	0	0	0	0	0	0	0	0	0	0	0	0
13:00																	0
13:15																	0
13:30																	0
13:45																	0
14:00																	0
14:15																	0
14:30																	0
14:45																	0
15:00																	0
15:15																	0
15:30																	0
15:45																	0
16:00	0	0	0	0	0	0	0	0	0	0	0	0	0	0	0	0	0
16:15	0	0	0	0	0	0	0	0	0	0	0	0	0	0	1	0	1
16:30	0	0	0	0	0	0	0	0	0	0	0	0	0	0	0	0	0
16:45	0	0	0	0	0	0	0	0	0	0	0	0	0	0	0	0	0
17:00	0	0	0	0	0	0	0	0	0	0	0	0	0	0	1	0	1
17:15	0	0	0	0	0	0	0	0	0	0	0	0	0	0	0	0	0
17:30	0	0	0	0	0	0	0	0	0	0	0	0	0	0	0	0	0
17:45	0	0	0	0	0	0	0	0	0	0	0	0	0	0	0	0	0
18:00	0	0	0	0	0	0	0	0	0	0	0	0	0	0	0	0	0
18:15																	0
18:30																	0
18:45																	0
19:00																	0
19:15																	0
19:30																	0
19:45																	0
20:00																	0
20:15																	0
20:30																	0
20:45																	0
21:00																	0
21:15																	0
21:30																	0
21:45																	0
22:00																	0
22:15																	0
22:30																	0
22:45																	0
23:00																	0
23:15																	0
23:30																	0
23:45																	0
Total	0	0	0	0	0	0	0	0	0	0	0	0	0	0	3	0	3
AM Peak Hr:																	7:00
Pk Vol	0	0	0	0	0	0	0	0	0	0	0	0	0	0	0	0	0
PHF	n/a	n/a	n/a	n/a	n/a	n/a	n/a	n/a	n/a	n/a	n/a	n/a	n/a	n/a	n/a	n/a	n/a
MID Peak Hr:																	12:00
Pk Vol	0	0	0	0	0	0	0	0	0	0	0	0	0	0	1	0	1
PHF	n/a	n/a	n/a	n/a	n/a	n/a	n/a	n/a	n/a	n/a	n/a	n/a	n/a	n/a	0.250	n/a	0.250
PM Peak Hr:																	16:30
Pk Vol	0	0	0	0	0	0	0	0	0	0	0	0	0	0	1	0	1
PHF	n/a	n/a	n/a	n/a	n/a	n/a	n/a	n/a	n/a	n/a	n/a	n/a	n/a	n/a	0.250	n/a	0.250

Intersection ID: 1805142
Count Date: 11/29/2018

7TH STREET & NORTHERN AVENUE

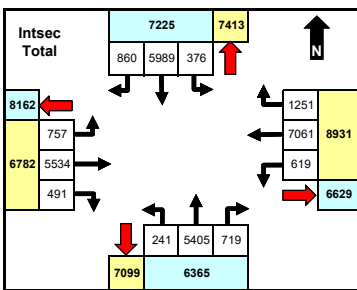
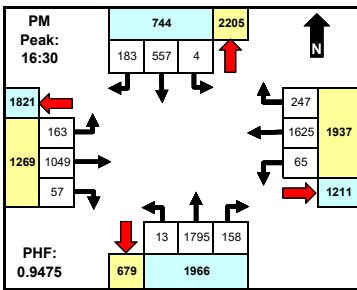
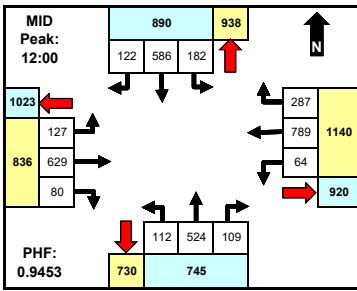
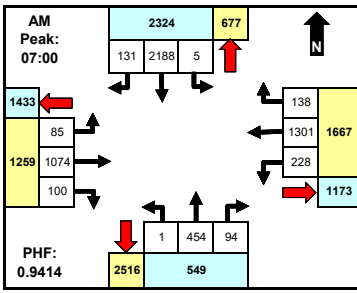

	North		East		South		West		Total
	App	Dep	App	Dep	App	Dep	App	Dep	
AM	2324	677	1667	1173	549	2516	1259	1433	5799
MID	890	938	1140	920	745	730	836	1023	3611
PM	744	2205	1937	1211	1966	679	1269	1821	5916
Total	7225	7413	8931	6629	6365	7099	6782	8162	29303

Comments

Unless shown otherwise, MID period defined as 10:00 AM - 2:00 PM. Peaks defined based on total intersection volume for all vehicle types.

Time	From North (SB)				From East (WB)				From South (NB)				From West (EB)				INTSEC	TOTAL
	LT	Thru	RT	U	LT	Thru	RT	U	LT	Thru	RT	U	LT	Thru	RT	U		
0:00																	0	
0:15																	0	
0:30																	0	
0:45																	0	
1:00																	0	
1:15																	0	
1:30																	0	
1:45																	0	
2:00																	0	
2:15																	0	
2:30																	0	
2:45																	0	
3:00																	0	
3:15																	0	
3:30																	0	
3:45																	0	
4:00																	0	
4:15																	0	
4:30																	0	
4:45																	0	
5:00																	0	
5:15																	0	
5:30																	0	
5:45																	0	
6:00																	0	
6:15																	0	
6:30	4	385	27	0	34	181	16	0	0	61	10	0	16	277	22	0	1033	
6:45	1	415	34	0	54	290	30	0	0	73	8	0	10	293	26	0	1234	
7:00	2	557	32	0	59	295	35	0	1	84	22	0	16	252	29	0	1384	
7:15	1	531	30	0	59	315	21	0	0	98	22	0	16	299	21	0	1413	
7:30	2	630	32	0	56	330	37	0	0	133	24	0	21	250	25	0	1540	
7:45	0	470	37	0	54	361	45	0	0	138	26	0	32	273	25	0	1462	
8:00	4	463	47	0	35	259	32	0	0	107	28	0	30	232	25	0	1262	
8:15	3	320	33	0	29	263	20	0	0	130	20	0	35	264	21	0	1138	
8:30																	0	
8:45																	0	
9:00																	0	
9:15																	0	
9:30																	0	
9:45																	0	
10:00																	0	
10:15																	0	
10:30																	0	
10:45																	0	
11:00	37	146	38	0	14	156	52	0	13	134	17	0	26	168	17	0	818	
11:15	44	146	29	0	15	193	55	0	20	112	31	0	31	155	19	0	850	
11:30	35	162	30	0	21	207	60	0	23	133	23	0	29	191	19	0	933	
11:45	47	141	24	0	14	188	59	0	27	139	30	0	36	172	20	0	897	
12:00	45	142	28	0	19	169	77	0	22	135	16	0	35	149	28	0	865	
12:15	47	142	24	0	16	205	64	0	22	121	23	0	30	148	15	0	857	
12:30	41	133	28	0	17	215	77	0	39	140	25	0	31	173	15	0	934	
12:45	49	169	42	0	12	200	69	0	29	128	45	0	31	159	22	0	955	
13:00																	0	
13:15																	0	
13:30																	0	
13:45																	0	
14:00																	0	
14:15																	0	
14:30																	0	
14:45																	0	
15:00																	0	
15:15																	0	
15:30																	0	
15:45																	0	
16:00	6	122	36	0	7	379	60	0	16	423	48	0	36	238	14	0	1385	
16:15	1	110	35	0	10	432	70	0	4	399	47	0	46	299	25	0	1478	
16:30	0	132	49	0	17	413	60	0	2	491	27	0	28	246	18	0	1483	
16:45	0	133	44	0	19	436	80	0	5	417	52	0	45	315	15	0	1561	
17:00	3	154	50	0	9	356	44	0	2	464	39	0	44	168	13	0	1346	
17:15	1	138	40	0	20	420	63	0	4	423	40	0	46	320	11	0	1526	
17:30	1	125	47	0	8	369	50	0	8	486	53	0	44	270	19	0	1480	
17:45	2	123	44	0	21	429	75	0	4	435	43	0	43	223	27	0	1469	
18:00																	0	
18:15																	0	
18:30																	0	
18:45																	0	
19:00																	0	
19:15																	0	
19:30																	0	
19:45																	0	
20:00																	0	
20:15																	0	
20:30																	0	
20:45																	0	
21:00																	0	
21:15																	0	
21:30																	0	
21:45																	0	
22:00																	0	
22:15																	0	
22:30																	0	
22:45																	0	
23:00																	0	
23:15																	0	
23:30																	0	
23:45																	0	
Total	376	5983	860	0	619	7061	1251	0	241	5405	719	0	757	5534	491	0	29303	
AM Peak Hr:																	7:00	
Pk Vol	5	2188	131	0	228	1301	138	0	1	454	94	0	85	1074	100	0	5799	
PHF	0.625	0.868	0.885	n/a	0.966	0.901	0.767	n/a	0.250	0.817	0.904	n/a	0.664	0.898	0.862	n/a	0.941	
MID Peak Hr:																	12:00	
Pk Vol	182	586	122	0	64	789	287	0	112	524	109	0	127	629	80	0	3611	
PHF	0.929	0.867	0.726	n/a	0.842	0.917	0.932	n/a	0.718	0.936	0.606	n/a	0.907	0.909	0.714	n/a	0.945	
PM Peak Hr:																	16:30	
Pk Vol	4	657	183	0	65	1625	247	0	13	1796	168	0	163	1049	67	0	5916	
PHF	0.333	0.904	0.915	n/a	0.813	0.932	0.772	n/a	0.650	0.914	0.760	n/a	0.886	0.820	0.792	n/a	0.947	



Intersection ID: 1805142
Count Date: 11/29/2018

7TH STREET & NORTHERN AVENUE

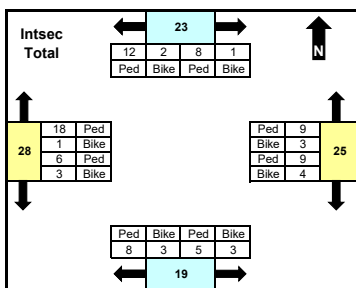
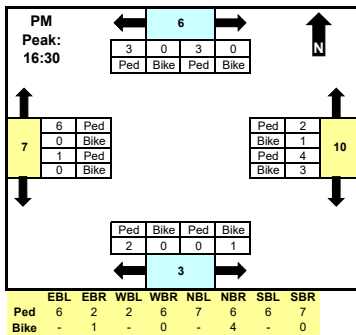
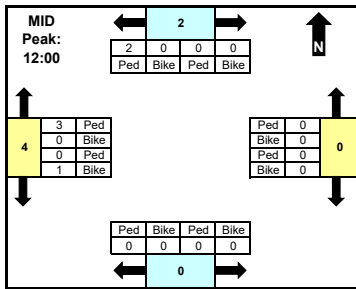
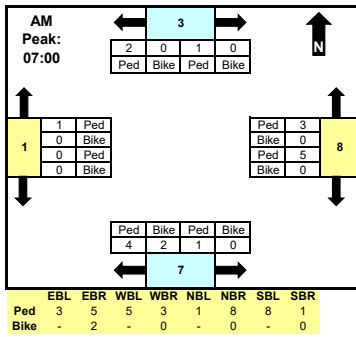

	North		East		South		West		Total
	CW	CCW	CW	CCW	CW	CCW	CW	CCW	
AM	1	2	5	3	6	1	1	0	19
MID	0	2	0	0	0	0	3	1	6
PM	3	3	7	3	2	1	6	1	26
Total	9	14	13	12	11	8	19	9	95

CW = Clockwise
CCW = Counter-clockwise

Comments

Unless shown otherwise, MID period defined as 10:00 AM - 2:00 PM. Crosswalk peaks defined based on total intersection volume for all vehicle types.

Time	North Leg		East Leg		South Leg		West Leg		INTSEC	TOTAL	
	CW	CCW	CW	CCW	CW	CCW	CW	CCW			
0:00										0	
0:15										0	
0:30										0	
0:45										0	
1:00										0	
1:15										0	
1:30										0	
1:45										0	
2:00										0	
2:15										0	
2:30										0	
2:45										0	
3:00										0	
3:15										0	
3:30										0	
3:45										0	
4:00										0	
4:15										0	
4:30										0	
4:45										0	
5:00										0	
5:15										0	
5:30										0	
5:45										0	
6:00										0	
6:15										0	
6:30	0	0	0	0	0	0	0	0	0	0	
6:45	0	0	0	0	1	1	0	0	0	2	
7:00	0	0	0	0	0	0	0	1	0	1	
7:15	0	0	1	0	4	2	2	1	0	10	
7:30	0	0	0	0	0	0	1	1	0	3	
7:45	1	0	1	0	1	0	1	0	0	5	
8:00	0	1	0	0	0	0	0	1	2	4	
8:15	0	0	1	0	0	0	1	0	0	3	
8:30										0	
8:45										0	
9:00										0	
9:15										0	
9:30										0	
9:45										0	
10:00										0	
10:15										0	
10:30										0	
10:45										0	
11:00	0	0	0	0	0	0	0	0	0	0	
11:15	1	0	1	0	0	0	1	1	0	7	
11:30	0	0	2	1	0	0	0	0	2	6	
11:45	0	0	0	0	0	0	0	0	0	0	
12:00	0	0	0	0	0	0	0	0	0	1	
12:15	0	0	0	0	0	0	0	2	0	2	
12:30	0	0	2	0	0	0	0	0	0	2	
12:45	0	0	0	0	0	0	0	1	0	1	
13:00										0	
13:15										0	
13:30										0	
13:45										0	
14:00										0	
14:15										0	
14:30										0	
14:45										0	
15:00										0	
15:15										0	
15:30										0	
15:45	0	0	1	1	0	0	1	1	1	10	
16:00										0	
16:15	1	0	0	0	0	0	0	2	0	5	
16:30	2	0	0	0	2	0	0	0	3	7	
16:45	0	0	1	0	0	2	1	1	0	7	
17:00	1	0	2	0	0	0	0	0	1	4	
17:15	0	0	0	0	4	1	0	0	2	8	
17:30	0	0	0	0	0	0	0	0	2	2	
17:45	2	0	0	0	0	2	0	0	1	5	
18:00										0	
18:15										0	
18:30										0	
18:45										0	
19:00										0	
19:15										0	
19:30										0	
19:45										0	
20:00										0	
20:15										0	
20:30										0	
20:45										0	
21:00										0	
21:15										0	
21:30										0	
21:45										0	
22:00										0	
22:15										0	
22:30										0	
22:45										0	
23:00										0	
23:15										0	
23:30										0	
23:45										0	
Total	8	1	12	2	9	4	9	3	8	3	95
AM Peak Hr:											7:00
PK Vol	1	0	2	0	5	0	3	0	4	2	19
MID Peak Hr:											12:00
PK Vol	0	0	2	0	0	0	0	0	0	3	6
PM Peak Hr:											16:30
PK Vol	3	0	3	0	4	3	2	1	2	0	25

Intersection ID: 1805142
Count Date: 11/29/2018

7TH STREET & NORTHERN AVENUE

From North (SB) From East (WB) From South (NB) From West (EB)
7TH STREET NORTHERN AVENUE 7TH STREET NORTHERN AVENUE INTSEC

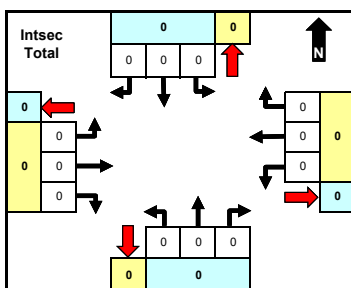
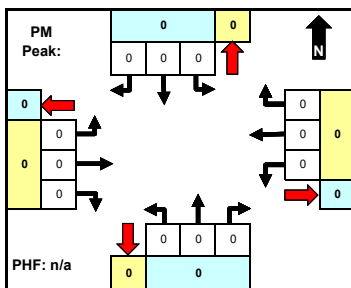
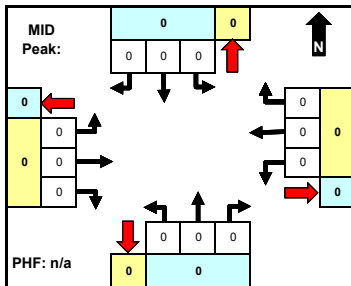
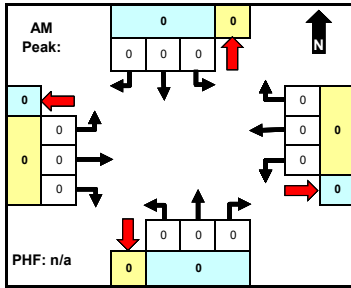

	North		East		South		West		Total
	App	Dep	App	Dep	App	Dep	App	Dep	
AM	0	0	0	0	0	0	0	0	0
MID	0	0	0	0	0	0	0	0	0
PM	0	0	0	0	0	0	0	0	0
Total	0	0	0	0	0	0	0	0	0

Comments

Unless shown otherwise, MID period defined as 10:00 AM - 2:00 PM. Peaks defined based on total intersection volume for all vehicle types.

Time	From North (SB)				From East (WB)				From South (NB)				From West (EB)				TOTAL
	LT	Thru	RT	U	LT	Thru	RT	U	LT	Thru	RT	U	LT	Thru	RT	U	
0:00																	0
0:15																	0
0:30																	0
0:45																	0
1:00																	0
1:15																	0
1:30																	0
1:45																	0
2:00																	0
2:15																	0
2:30																	0
2:45																	0
3:00																	0
3:15																	0
3:30																	0
3:45																	0
4:00																	0
4:15																	0
4:30																	0
4:45																	0
5:00																	0
5:15																	0
5:30																	0
5:45																	0
6:00																	0
6:15																	0
6:30	0	0	0	0	0	0	0	0	0	0	0	0	0	0	0	0	0
6:45	0	0	0	0	0	0	0	0	0	0	0	0	0	0	0	0	0
7:00	0	0	0	0	0	0	0	0	0	0	0	0	0	0	0	0	0
7:15	0	0	0	0	0	0	0	0	0	0	0	0	0	0	0	0	0
7:30	0	0	0	0	0	0	0	0	0	0	0	0	0	0	0	0	0
7:45	0	0	0	0	0	0	0	0	0	0	0	0	0	0	0	0	0
8:00	0	0	0	0	0	0	0	0	0	0	0	0	0	0	0	0	0
8:15	0	0	0	0	0	0	0	0	0	0	0	0	0	0	0	0	0
8:30																	0
8:45																	0
9:00																	0
9:15																	0
9:30																	0
9:45																	0
10:00																	0
10:15																	0
10:30																	0
10:45																	0
11:00	0	0	0	0	0	0	0	0	0	0	0	0	0	0	0	0	0
11:15	0	0	0	0	0	0	0	0	0	0	0	0	0	0	0	0	0
11:30	0	0	0	0	0	0	0	0	0	0	0	0	0	0	0	0	0
11:45	0	0	0	0	0	0	0	0	0	0	0	0	0	0	0	0	0
12:00	0	0	0	0	0	0	0	0	0	0	0	0	0	0	0	0	0
12:15	0	0	0	0	0	0	0	0	0	0	0	0	0	0	0	0	0
12:30	0	0	0	0	0	0	0	0	0	0	0	0	0	0	0	0	0
12:45	0	0	0	0	0	0	0	0	0	0	0	0	0	0	0	0	0
13:00																	0
13:15																	0
13:30																	0
13:45																	0
14:00																	0
14:15																	0
14:30																	0
14:45																	0
15:00																	0
15:15																	0
15:30																	0
15:45																	0
16:00	0	0	0	0	0	0	0	0	0	0	0	0	0	0	0	0	0
16:15	0	0	0	0	0	0	0	0	0	0	0	0	0	0	0	0	0
16:30	0	0	0	0	0	0	0	0	0	0	0	0	0	0	0	0	0
16:45	0	0	0	0	0	0	0	0	0	0	0	0	0	0	0	0	0
17:00	0	0	0	0	0	0	0	0	0	0	0	0	0	0	0	0	0
17:15	0	0	0	0	0	0	0	0	0	0	0	0	0	0	0	0	0
17:30	0	0	0	0	0	0	0	0	0	0	0	0	0	0	0	0	0
17:45	0	0	0	0	0	0	0	0	0	0	0	0	0	0	0	0	0
18:00																	0
18:15																	0
18:30																	0
18:45																	0
19:00																	0
19:15																	0
19:30																	0
19:45																	0
20:00																	0
20:15																	0
20:30																	0
20:45																	0
21:00																	0
21:15																	0
21:30																	0
21:45																	0
22:00																	0
22:15																	0
22:30																	0
22:45																	0
23:00																	0
23:15																	0
23:30																	0
23:45																	0
Total	0	0	0	0	0	0	0	0	0	0	0	0	0	0	0	0	0
AM Peak Hr:																	7:00
Pk Vol	0	0	0	0	0	0	0	0	0	0	0	0	0	0	0	0	0
PHF	n/a	n/a	n/a	n/a	n/a	n/a	n/a	n/a	n/a	n/a	n/a	n/a	n/a	n/a	n/a	n/a	n/a
MID Peak Hr:																	12:00
Pk Vol	0	0	0	0	0	0	0	0	0	0	0	0	0	0	0	0	0
PHF	n/a	n/a	n/a	n/a	n/a	n/a	n/a	n/a	n/a	n/a	n/a	n/a	n/a	n/a	n/a	n/a	n/a
PM Peak Hr:																	16:30
Pk Vol	0	0	0	0	0	0	0	0	0	0	0	0	0	0	0	0	0
PHF	n/a	n/a	n/a	n/a	n/a	n/a	n/a	n/a	n/a	n/a	n/a	n/a	n/a	n/a	n/a	n/a	n/a

Intersection ID: 1805153
Count Date: 11/29/2018

N 7TH ST & BUTLER ROAD

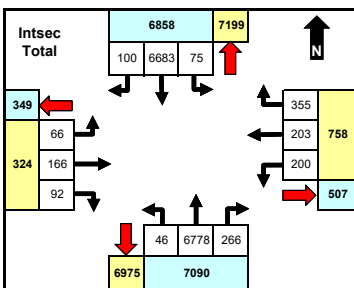
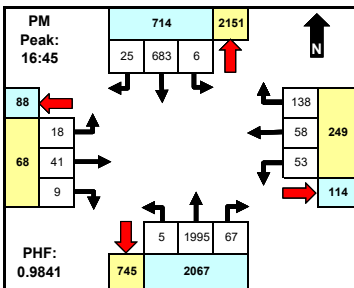
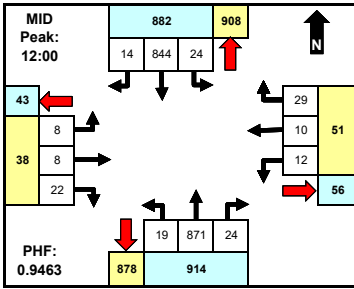
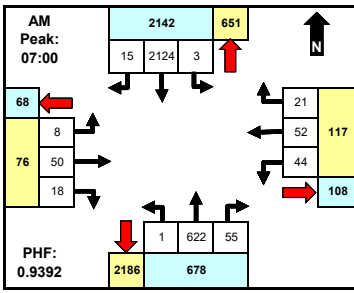

	North		East		South		West		Total
	App	Dep	App	Dep	App	Dep	App	Dep	
AM	2142	651	117	108	678	2186	76	68	3013
MID	882	908	51	56	914	878	38	43	1885
PM	714	2151	249	114	2067	745	68	88	3098
Total	6858	7199	758	507	7090	6975	324	349	15030

Comments

Unless shown otherwise, MID period defined as 10:00 AM - 2:00 PM. Peaks defined based on total intersection volume for all vehicle types.

Time	From North (SB)		From East (WB)		From South (NB)		From West (EB)		INTSEC	TOTAL							
	N 7TH ST		BUTLER ROAD		N 7TH ST		BUTLER ROAD										
	LT	Thru	RT	U	LT	Thru	RT	U									
0:00										0							
0:15										0							
0:30										0							
0:45										0							
1:00										0							
1:15										0							
1:30										0							
1:45										0							
2:00										0							
2:15										0							
2:30										0							
2:45										0							
3:00										0							
3:15										0							
3:30										0							
3:45										0							
4:00										0							
4:15										0							
4:30										0							
4:45										0							
5:00										0							
5:15										0							
5:30										0							
5:45										0							
6:00										0							
6:15										0							
6:30	0	373	0	0	7	3	4	0	0	80	8	0	1	8	4	0	488
6:45	1	483	3	0	7	8	4	0	0	92	9	0	4	3	5	0	619
7:00	0	509	1	0	15	7	4	0	0	130	14	0	1	12	4	0	697
7:15	0	601	6	0	10	26	5	0	0	132	10	0	0	9	3	0	802
7:30	1	558	6	0	12	7	5	0	0	160	13	0	2	18	7	0	789
7:45	2	456	2	0	7	12	7	0	1	200	18	0	5	11	4	0	725
8:00	2	450	2	0	16	1	8	0	1	169	10	0	0	7	7	0	673
8:15	1	335	0	0	5	5	5	0	1	187	19	0	4	4	5	0	571
8:30																	0
8:45																	0
9:00																	0
9:15																	0
9:30																	0
9:45																	0
10:00																	0
10:15																	0
10:30																	0
10:45																	0
11:00	6	185	2	0	6	1	6	0	3	195	8	0	1	3	3	0	419
11:15	11	204	1	0	5	2	15	0	1	179	9	0	3	3	5	0	438
11:30	6	210	2	0	6	2	15	0	11	200	4	0	2	1	1	0	460
11:45	10	193	4	0	5	0	5	0	0	228	2	0	1	2	4	0	454
12:00	6	207	6	0	3	2	7	0	5	229	5	0	2	2	3	0	477
12:15	5	185	1	0	4	0	12	0	7	186	7	0	2	3	11	0	423
12:30	4	218	2	0	3	3	5	0	2	232	7	0	3	1	7	0	487
12:45	9	234	5	0	2	5	5	0	5	224	5	0	1	2	1	0	498
13:00																	0
13:15																	0
13:30																	0
13:45																	0
14:00																	0
14:15																	0
14:30																	0
14:45																	0
15:00																	0
15:15																	0
15:30																	0
15:45																	0
16:00	0	138	4	0	4	10	20	0	1	431	10	0	3	10	0	0	631
16:15	1	156	11	0	6	18	36	0	0	504	17	0	6	9	4	0	768
16:30	2	147	7	0	13	19	21	0	2	524	13	0	6	7	3	0	764
16:45	2	173	3	0	8	18	36	0	1	507	20	0	5	13	1	0	787
17:00	0	187	5	0	16	14	29	0	1	473	19	0	5	14	3	0	766
17:15	0	156	12	0	13	17	38	0	1	516	9	0	2	7	3	0	774
17:30	4	167	5	0	16	9	35	0	2	499	19	0	6	7	2	0	771
17:45	2	158	10	0	11	14	28	0	1	501	11	0	1	10	2	0	749
18:00																	0
18:15																	0
18:30																	0
18:45																	0
19:00																	0
19:15																	0
19:30																	0
19:45																	0
20:00																	0
20:15																	0
20:30																	0
20:45																	0
21:00																	0
21:15																	0
21:30																	0
21:45																	0
22:00																	0
22:15																	0
22:30																	0
22:45																	0
23:00																	0
23:15																	0
23:30																	0
23:45																	0
Total	75	6683	100	0	200	203	355	0	46	6778	266	0	66	166	92	0	15030
AM Peak Hr:																	7:00
PK Vol	3	2124	15	0	44	52	21	0	1	622	65	0	8	50	18	0	3013
PHF	0.375	0.884	0.625	n/a	0.733	0.500	0.750	n/a	0.250	0.778	0.764	n/a	0.400	0.694	0.643	n/a	0.939
MID Peak Hr:																	12:00
PK Vol	24	844	14	0	12	10	29	0	19	871	24	0	8	8	22	0	1885
PHF	0.667	0.902	0.583	n/a	0.750	0.500	0.604	n/a	0.679	0.939	0.857	n/a	0.667	0.667	0.500	n/a	0.945
PM Peak Hr:																	16:45
PK Vol	6	683	25	0	63	68	138	0	5	1995	67	0	18	41	9	0	3098
PHF	0.375	0.913	0.521	n/a	0.828	0.806	0.908	n/a	0.625	0.967	0.838	n/a	0.750	0.732	0.750	n/a	0.984



Intersection ID: 1805153
Count Date: 11/29/2018

N 7TH ST & BUTLER ROAD

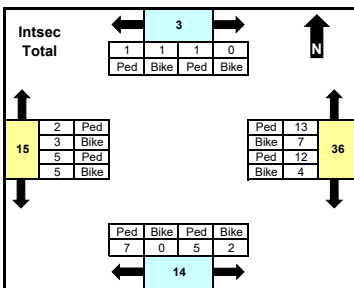
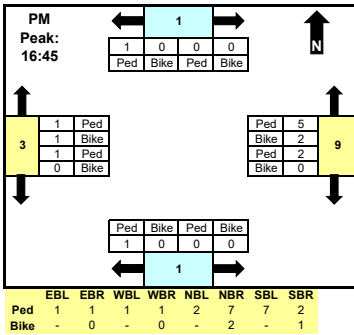
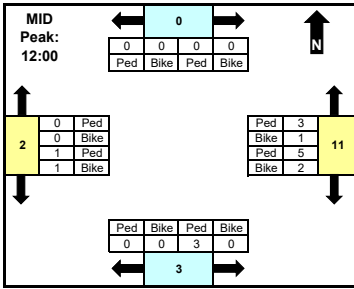
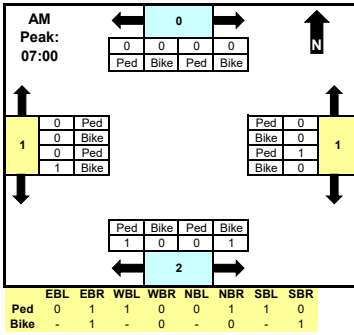

	North		East		South		West		Total
	CW	CCW	CW	CCW	CW	CCW	CW	CCW	
AM	0	0	1	0	1	1	0	1	4
MID	0	0	7	4	0	3	0	2	16
PM	0	1	2	7	1	0	2	1	14
Total	1	2	16	20	7	7	5	10	68

CW = Clockwise
CCW = Counter-clockwise

Comments
Unless shown otherwise, MID period defined as 10:00 AM - 2:00 PM. Crosswalk peaks defined based on total intersection volume for all vehicle types.

Time	North Leg		East Leg		South Leg		West Leg		INTSEC	TOTAL						
	CW	CCW	CW	CCW	CW	CCW	CW	CCW								
0:00										0						
0:15										0						
0:30										0						
0:45										0						
1:00										0						
1:15										0						
1:30										0						
1:45										0						
2:00										0						
2:15										0						
2:30										0						
2:45										0						
3:00										0						
3:15										0						
3:30										0						
3:45										0						
4:00										0						
4:15										0						
4:30										0						
4:45										0						
5:00										0						
5:15										0						
5:30										0						
5:45										0						
6:00										0						
6:15										0						
6:30	0	0	0	0	0	0	0	0	1	0						
6:45	0	0	0	0	0	0	0	0	0	1						
7:00	0	0	0	1	0	0	0	0	0	1						
7:15	0	0	0	0	0	0	0	0	0	0						
7:30	0	0	0	0	0	0	1	0	0	1						
7:45	0	0	0	0	0	0	0	0	0	0						
8:00	0	0	0	0	1	2	2	0	1	0						
8:15	0	0	0	0	0	0	1	0	0	0						
8:30										0						
8:45										0						
9:00										0						
9:15										0						
9:30										0						
9:45										0						
10:00										0						
10:15										0						
10:30										0						
10:45										0						
11:00	0	0	0	0	0	0	0	1	0	2						
11:15	0	0	0	0	0	1	1	0	0	1						
11:30	0	0	0	0	0	0	0	0	0	0						
11:45	0	0	0	1	0	0	0	0	1	0						
12:00	0	0	0	1	1	0	0	0	0	1						
12:15	0	0	0	1	0	2	1	0	0	5						
12:30	0	0	0	1	0	1	0	0	0	2						
12:45	0	0	0	2	1	0	0	0	1	6						
13:00										0						
13:15										0						
13:30										0						
13:45										0						
14:00										0						
14:15										0						
14:30										0						
14:45										0						
15:00										0						
15:15										0						
15:30										0						
15:45										0						
16:00	0	0	0	0	0	1	0	2	0	3						
16:15	0	0	0	0	0	1	0	0	0	1						
16:30	0	0	0	0	3	0	1	2	0	7						
16:45	0	0	0	0	0	3	2	0	0	6						
17:00	0	0	0	0	0	2	0	0	0	3						
17:15	0	0	1	0	1	0	0	0	0	2						
17:30	0	0	0	0	1	0	0	1	0	3						
17:45	1	0	0	0	0	0	1	0	0	3						
18:00										0						
18:15										0						
18:30										0						
18:45										0						
19:00										0						
19:15										0						
19:30										0						
19:45										0						
20:00										0						
20:15										0						
20:30										0						
20:45										0						
21:00										0						
21:15										0						
21:30										0						
21:45										0						
22:00										0						
22:15										0						
22:30										0						
22:45										0						
23:00										0						
23:15										0						
23:30										0						
23:45										0						
Total	1	0	1	1	12	4	13	7	0	5	2	2	3	5	5	68
AM Peak Hr:																7:00
PK Vol	0	0	0	0	1	0	0	0	1	0	0	1	0	0	1	4
MID Peak Hr:																12:00
PK Vol	0	0	0	0	5	2	3	1	0	0	3	0	0	1	1	16
PM Peak Hr:																16:45
PK Vol	0	0	1	0	2	0	5	2	1	0	0	0	1	1	1	14

Intersection ID: 1805153
Count Date: 11/29/2018

N 7TH ST & BUTLER ROAD

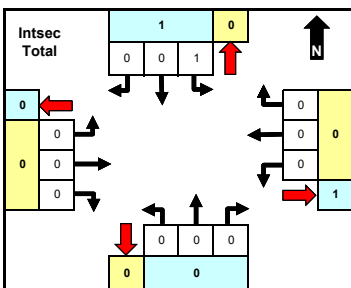
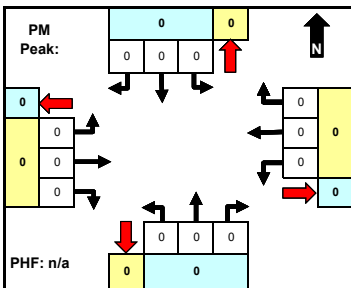
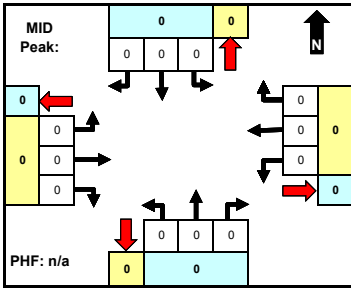
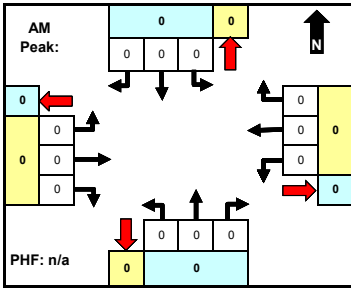

	North		East		South		West		Total
	App	Dep	App	Dep	App	Dep	App	Dep	
AM	0	0	0	0	0	0	0	0	0
MID	0	0	0	0	0	0	0	0	0
PM	0	0	0	0	0	0	0	0	0
Total	1	0	0	1	0	0	0	0	1

Comments

Unless shown otherwise, MID period defined as 10:00 AM - 2:00 PM. Peaks defined based on total intersection volume for all vehicle types.

Time	From North (SB)		From East (WB)		From South (NB)		From West (EB)		INTSEC	TOTAL
	N 7TH ST		BUTLER ROAD		N 7TH ST		BUTLER ROAD			
	LT	Thru	RT	U	LT	Thru	RT	U		
0:00										0
0:15										0
0:30										0
0:45										0
1:00										0
1:15										0
1:30										0
1:45										0
2:00										0
2:15										0
2:30										0
2:45										0
3:00										0
3:15										0
3:30										0
3:45										0
4:00										0
4:15										0
4:30										0
4:45										0
5:00										0
5:15										0
5:30										0
5:45										0
6:00										0
6:15										0
6:30	0	0	0	0	0	0	0	0	0	0
6:45	0	0	0	0	0	0	0	0	0	0
7:00	0	0	0	0	0	0	0	0	0	0
7:15	0	0	0	0	0	0	0	0	0	0
7:30	0	0	0	0	0	0	0	0	0	0
7:45	0	0	0	0	0	0	0	0	0	0
8:00	0	0	0	0	0	0	0	0	0	0
8:15	0	0	0	0	0	0	0	0	0	0
8:30										0
8:45										0
9:00										0
9:15										0
9:30										0
9:45										0
10:00										0
10:15										0
10:30										0
10:45										0
11:00	0	0	0	0	0	0	0	0	0	0
11:15	0	0	0	0	0	0	0	0	0	0
11:30	0	0	0	0	0	0	0	0	0	0
11:45	1	0	0	0	0	0	0	0	0	1
12:00	0	0	0	0	0	0	0	0	0	0
12:15	0	0	0	0	0	0	0	0	0	0
12:30	0	0	0	0	0	0	0	0	0	0
12:45	0	0	0	0	0	0	0	0	0	0
13:00										0
13:15										0
13:30										0
13:45										0
14:00										0
14:15										0
14:30										0
14:45										0
15:00										0
15:15										0
15:30										0
15:45										0
16:00	0	0	0	0	0	0	0	0	0	0
16:15	0	0	0	0	0	0	0	0	0	0
16:30	0	0	0	0	0	0	0	0	0	0
16:45	0	0	0	0	0	0	0	0	0	0
17:00	0	0	0	0	0	0	0	0	0	0
17:15	0	0	0	0	0	0	0	0	0	0
17:30	0	0	0	0	0	0	0	0	0	0
17:45	0	0	0	0	0	0	0	0	0	0
18:00										0
18:15										0
18:30										0
18:45										0
19:00										0
19:15										0
19:30										0
19:45										0
20:00										0
20:15										0
20:30										0
20:45										0
21:00										0
21:15										0
21:30										0
21:45										0
22:00										0
22:15										0
22:30										0
22:45										0
23:00										0
23:15										0
23:30										0
23:45										0
Total	1	0	0	0	0	0	0	0	0	1
AM Peak Hr:	7:00									
Pk Vol	0	0	0	0	0	0	0	0	0	0
PHF	n/a	n/a	n/a	n/a	n/a	n/a	n/a	n/a	n/a	n/a
MID Peak Hr:	12:00									
Pk Vol	0	0	0	0	0	0	0	0	0	0
PHF	n/a	n/a	n/a	n/a	n/a	n/a	n/a	n/a	n/a	n/a
PM Peak Hr:	16:45									
Pk Vol	0	0	0	0	0	0	0	0	0	0
PHF	n/a	n/a	n/a	n/a	n/a	n/a	n/a	n/a	n/a	n/a

Intersection ID: 1805154
Count Date: 11/29/2018

N 7TH ST & ALICE AVENUE

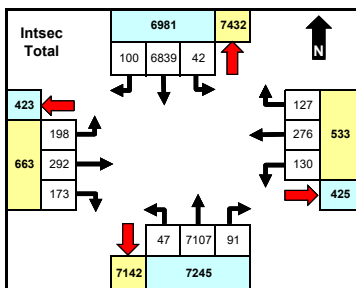
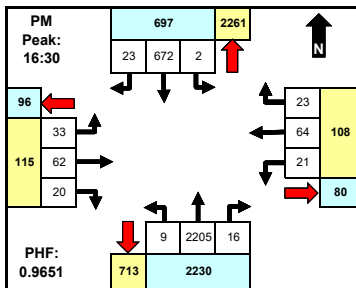
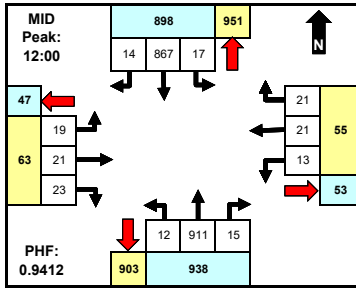
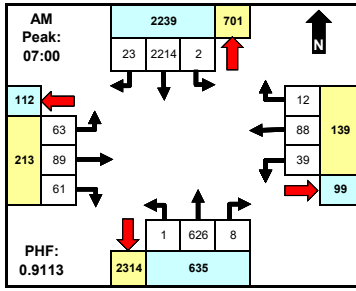

	North		East		South		West		Total
	App	Dep	App	Dep	App	Dep	App	Dep	
AM	2239	701	139	99	635	2314	213	112	3226
MID	898	951	55	53	938	903	63	47	1954
PM	697	2261	108	80	2230	713	115	96	3150
Total	6981	7432	533	425	7245	7142	663	423	15422

Comments

Unless shown otherwise, MID period defined as 10:00 AM - 2:00 PM. Peaks defined based on total intersection volume for all vehicle types.

Time	From North (SB)				From East (WB)				From South (NB)				From West (EB)				INTSEC	TOTAL
	N 7TH ST		ALICE AVENUE		N 7TH ST		ALICE AVENUE		N 7TH ST		ALICE AVENUE		N 7TH ST		ALICE AVENUE			
	LT	Thru	RT	U	LT	Thru	RT	U	LT	Thru	RT	U	LT	Thru	RT	U		
0:00																	0	
0:15																	0	
0:30																	0	
0:45																	0	
1:00																	0	
1:15																	0	
1:30																	0	
1:45																	0	
2:00																	0	
2:15																	0	
2:30																	0	
2:45																	0	
3:00																	0	
3:15																	0	
3:30																	0	
3:45																	0	
4:00																	0	
4:15																	0	
4:30																	0	
4:45																	0	
5:00																	0	
5:15																	0	
5:30																	0	
5:45																	0	
6:00																	0	
6:15																	0	
6:30	0	390	0	0	6	7	1	0	1	74	2	0	2	6	3	0	492	
6:45	0	485	6	0	3	6	2	0	0	117	2	0	2	7	9	0	639	
7:00	0	533	11	0	6	4	6	0	0	125	1	0	4	8	4	0	702	
7:15	0	616	7	0	11	25	2	0	0	135	1	0	9	22	20	0	848	
7:30	1	599	3	0	17	27	2	0	1	152	3	0	23	38	19	0	885	
7:45	1	466	2	0	5	32	2	0	0	214	3	0	27	21	18	0	791	
8:00	3	441	1	0	4	9	4	0	2	170	1	0	8	19	9	0	671	
8:15	1	325	4	0	3	10	2	0	0	197	4	0	5	7	3	0	561	
8:30																	0	
8:45																	0	
9:00																	0	
9:15																	0	
9:30																	0	
9:45																	0	
10:00																	0	
10:15																	0	
10:30																	0	
10:45																	0	
11:00	3	182	0	0	7	2	8	0	1	195	2	0	2	1	4	0	407	
11:15	6	197	4	0	5	2	5	0	1	194	3	0	3	7	8	0	435	
11:30	2	210	4	0	3	3	5	0	8	191	5	0	6	4	9	0	450	
11:45	3	208	0	0	3	3	2	0	4	218	4	0	7	3	5	0	460	
12:00	4	216	2	0	3	6	4	0	1	236	5	0	6	8	7	0	498	
12:15	3	190	4	0	2	9	6	0	8	210	1	0	5	2	5	0	445	
12:30	5	221	4	0	4	2	5	0	1	235	4	0	4	4	3	0	492	
12:45	5	240	4	0	4	4	6	0	2	230	5	0	4	7	8	0	519	
13:00																	0	
13:15																	0	
13:30																	0	
13:45																	0	
14:00																	0	
14:15																	0	
14:30																	0	
14:45																	0	
15:00																	0	
15:15																	0	
15:30																	0	
15:45																	0	
16:00	0	149	0	0	4	13	8	0	1	457	3	0	10	15	2	0	662	
16:15	1	155	9	0	8	17	13	0	4	520	5	0	18	21	5	0	776	
16:30	0	148	6	0	1	20	7	0	3	568	4	0	11	16	6	0	790	
16:45	1	179	9	0	7	14	4	0	3	565	5	0	6	17	6	0	816	
17:00	0	185	5	0	6	15	4	0	1	499	4	0	7	10	3	0	739	
17:15	1	160	3	0	7	15	8	0	2	573	3	0	9	19	5	0	805	
17:30	0	176	8	0	6	19	12	0	1	531	12	0	9	10	5	0	789	
17:45	2	168	4	0	5	12	9	0	2	501	9	0	11	20	7	0	750	
18:00																	0	
18:15																	0	
18:30																	0	
18:45																	0	
19:00																	0	
19:15																	0	
19:30																	0	
19:45																	0	
20:00																	0	
20:15																	0	
20:30																	0	
20:45																	0	
21:00																	0	
21:15																	0	
21:30																	0	
21:45																	0	
22:00																	0	
22:15																	0	
22:30																	0	
22:45																	0	
23:00																	0	
23:15																	0	
23:30																	0	
23:45																	0	
Total	42	6839	100	0	130	276	427	0	47	7107	91	0	198	292	173	0	15422	
AM Peak Hr:																	7:00	
PK Vol	2	2214	23	0	39	88	12	0	1	626	8	0	63	89	61	0	3226	
PHF	0.500	0.899	0.523	n/a	0.574	0.688	0.500	n/a	0.250	0.731	0.667	n/a	0.583	0.586	0.763	n/a	0.911	
MID Peak Hr:																	12:00	
PK Vol	17	867	14	0	13	21	21	0	12	911	15	0	19	21	23	0	1954	
PHF	0.850	0.903	0.875	n/a	0.813	0.583	0.875	n/a	0.375	0.965	0.750	n/a	0.792	0.656	0.719	n/a	0.941	
PM Peak Hr:																	16:30	
PK Vol	2	672	23	0	21	64	23	0	9	2205	16	0	33	62	20	0	3150	
PHF	0.500	0.908	0.639	n/a	0.750	0.800	0.719	n/a	0.750</									



Intersection ID: 1805154
Count Date: 11/29/2018

N 7TH ST & ALICE AVENUE

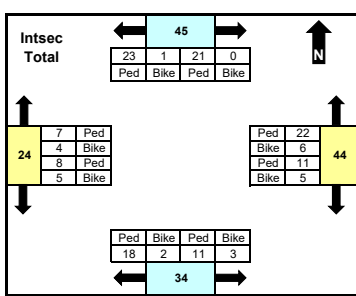
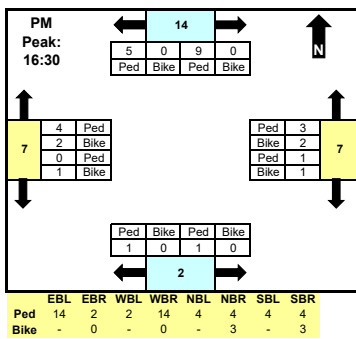
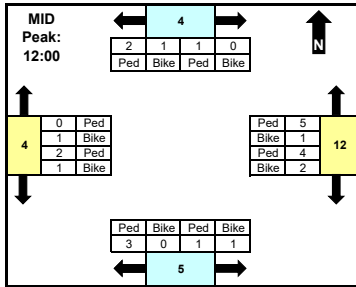
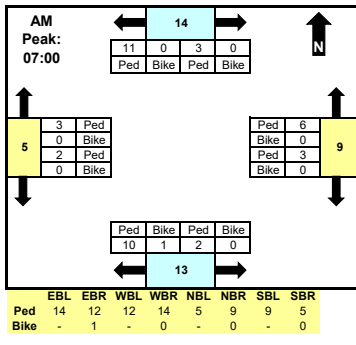

	North		East		South		West		Total
	CW	CCW	CW	CCW	CW	CCW	CW	CCW	
AM	3	11	3	6	11	2	3	2	41
MID	1	3	6	6	3	2	1	3	25
PM	9	5	2	5	1	1	6	1	30
Total	21	24	16	28	20	14	11	13	147

CW = Clockwise
CCW = Counter-clockwise

Comments
Unless shown otherwise, MID period defined as 10:00 AM - 2:00 PM. Crosswalk peaks defined based on total intersection volume for all vehicle types.

Time	North Leg		East Leg		South Leg		West Leg		INTSEC	TOTAL							
	CW	CCW	CW	CCW	CW	CCW	CW	CCW									
0:00										0							
0:15										0							
0:30										0							
0:45										0							
1:00										0							
1:15										0							
1:30										0							
1:45										0							
2:00										0							
2:15										0							
2:30										0							
2:45										0							
3:00										0							
3:15										0							
3:30										0							
3:45										0							
4:00										0							
4:15										0							
4:30										0							
4:45										0							
5:00										0							
5:15										0							
5:30										0							
5:45										0							
6:00										0							
6:15										0							
6:30	0	0	1	0	0	0	1	1	0	0	3						
6:45	0	0	0	0	0	0	0	0	0	0	2						
7:00	1	0	5	0	2	0	4	0	0	0	15						
7:15	1	0	1	0	0	0	0	0	5	1	11						
7:30	1	0	1	0	1	0	0	0	1	0	7						
7:45	0	0	4	0	0	2	0	1	0	0	8						
8:00	1	0	1	0	0	2	2	0	1	1	8						
8:15	0	0	0	0	0	0	1	1	0	0	3						
8:30											0						
8:45											0						
9:00											0						
9:15											0						
9:30											0						
9:45											0						
10:00											0						
10:15											0						
10:30											0						
10:45											0						
11:00	0	0	2	0	1	0	1	0	0	0	5						
11:15	0	0	0	0	0	0	0	0	0	1	2						
11:30	1	0	1	0	0	0	1	0	0	0	4						
11:45	0	0	0	0	0	0	0	4	0	0	6						
12:00	1	0	0	0	1	0	0	0	0	1	5						
12:15	0	0	1	0	1	0	3	0	0	0	8						
12:30	0	0	0	0	2	0	2	1	0	0	5						
12:45	0	0	1	1	1	0	0	1	1	0	7						
13:00											0						
13:15											0						
13:30											0						
13:45											0						
14:00											0						
14:15											0						
14:30											0						
14:45											0						
15:00											0						
15:15											0						
15:30											0						
15:45	0	0	0	0	0	0	1	0	0	0	1						
16:00											0						
16:15	2	0	0	0	1	0	1	0	0	0	6						
16:30	3	0	1	0	0	0	1	1	0	0	10						
16:45	5	0	3	0	0	0	1	0	0	1	12						
17:00	1	0	1	0	1	0	2	0	0	0	7						
17:15	0	0	0	0	1	0	0	0	0	0	1						
17:30	2	0	0	0	1	0	0	0	1	0	5						
17:45	2	0	0	0	0	0	1	1	0	0	6						
18:00											0						
18:15											0						
18:30											0						
18:45											0						
19:00											0						
19:15											0						
19:30											0						
19:45											0						
20:00											0						
20:15											0						
20:30											0						
20:45											0						
21:00											0						
21:15											0						
21:30											0						
21:45											0						
22:00											0						
22:15											0						
22:30											0						
22:45											0						
23:00											0						
23:15											0						
23:30											0						
23:45											0						
Total	21	0	23	1	11	5	22	6	18	2	11	3	7	4	8	5	147
AM Peak Hr:																	7:00
PK Vol	3	0	11	0	3	0	6	0	10	1	2	0	3	0	2	0	41
MID Peak Hr:																	12:00
PK Vol	1	0	2	1	4	2	5	1	3	0	1	1	0	1	2	1	25
PM Peak Hr:																	16:30
PK Vol	9	0	5	0	1	1	3	2	1	0	1	0	4	2	0	1	30

Intersection ID: 1805154
Count Date: 11/29/2018

N 7TH ST & ALICE AVENUE

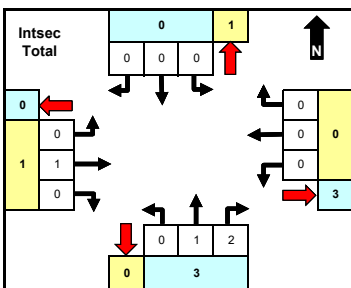
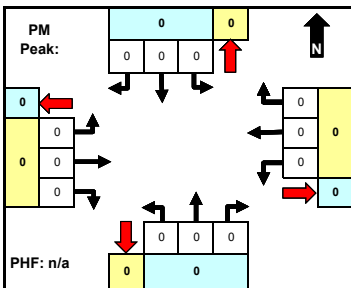
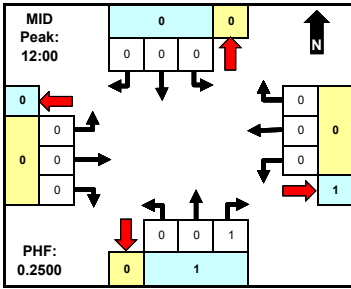
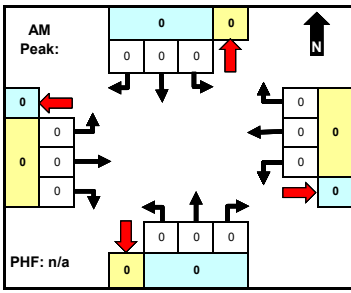

	North		East		South		West		Total
	App	Dep	App	Dep	App	Dep	App	Dep	
AM	0	0	0	0	0	0	0	0	0
MID	0	0	0	1	1	0	0	0	1
PM	0	0	0	0	0	0	0	0	0
Total	0	1	0	3	3	0	1	0	4

Comments

Unless shown otherwise, MID period defined as 10:00 AM - 2:00 PM. Peaks defined based on total intersection volume for all vehicle types.

Time	From North (SB)				From East (WB)				From South (NB)				From West (EB)				INTSEC	TOTAL
	N 7TH ST		ALICE AVENUE		N 7TH ST		ALICE AVENUE		N 7TH ST		ALICE AVENUE		N 7TH ST		ALICE AVENUE			
	LT	Thru	RT	U	LT	Thru	RT	U	LT	Thru	RT	U	LT	Thru	RT	U		
0:00																	0	
0:15																	0	
0:30																	0	
0:45																	0	
1:00																	0	
1:15																	0	
1:30																	0	
1:45																	0	
2:00																	0	
2:15																	0	
2:30																	0	
2:45																	0	
3:00																	0	
3:15																	0	
3:30																	0	
3:45																	0	
4:00																	0	
4:15																	0	
4:30																	0	
4:45																	0	
5:00																	0	
5:15																	0	
5:30																	0	
5:45																	0	
6:00																	0	
6:15																	0	
6:30	0	0	0	0	0	0	0	0	0	0	0	0	0	0	0	0	0	
6:45	0	0	0	0	0	0	0	0	0	0	0	0	0	0	0	0	0	
7:00	0	0	0	0	0	0	0	0	0	0	0	0	0	0	0	0	0	
7:15	0	0	0	0	0	0	0	0	0	0	0	0	0	0	0	0	0	
7:30	0	0	0	0	0	0	0	0	0	0	0	0	0	0	0	0	0	
7:45	0	0	0	0	0	0	0	0	0	0	0	0	0	0	0	0	0	
8:00	0	0	0	0	0	0	0	0	0	0	0	0	0	0	0	0	0	
8:15	0	0	0	0	0	0	0	0	0	0	0	0	0	0	1	0	1	
8:30																	0	
8:45																	0	
9:00																	0	
9:15																	0	
9:30																	0	
9:45																	0	
10:00																	0	
10:15																	0	
10:30																	0	
10:45																	0	
11:00	0	0	0	0	0	0	0	0	0	0	0	0	0	0	0	0	0	
11:15	0	0	0	0	0	0	0	0	0	0	0	0	0	0	0	0	1	
11:30	0	0	0	0	0	0	0	0	0	0	0	0	0	0	0	0	0	
11:45	0	0	0	0	0	0	0	0	0	0	0	0	0	0	0	0	0	
12:00	0	0	0	0	0	0	0	0	0	0	0	0	0	0	0	0	1	
12:15	0	0	0	0	0	0	0	0	0	0	0	0	0	0	0	0	0	
12:30	0	0	0	0	0	0	0	0	0	0	0	0	0	0	0	0	0	
12:45	0	0	0	0	0	0	0	0	0	0	0	0	0	0	0	0	0	
13:00																	0	
13:15																	0	
13:30																	0	
13:45																	0	
14:00																	0	
14:15																	0	
14:30																	0	
14:45																	0	
15:00																	0	
15:15																	0	
15:30																	0	
15:45																	0	
16:00	0	0	0	0	0	0	0	0	0	1	0	0	0	0	0	0	1	
16:15	0	0	0	0	0	0	0	0	0	0	0	0	0	0	0	0	0	
16:30	0	0	0	0	0	0	0	0	0	0	0	0	0	0	0	0	0	
16:45	0	0	0	0	0	0	0	0	0	0	0	0	0	0	0	0	0	
17:00	0	0	0	0	0	0	0	0	0	0	0	0	0	0	0	0	0	
17:15	0	0	0	0	0	0	0	0	0	0	0	0	0	0	0	0	0	
17:30	0	0	0	0	0	0	0	0	0	0	0	0	0	0	0	0	0	
17:45	0	0	0	0	0	0	0	0	0	0	0	0	0	0	0	0	0	
18:00	0	0	0	0	0	0	0	0	0	0	0	0	0	0	0	0	0	
18:15																	0	
18:30																	0	
18:45																	0	
19:00																	0	
19:15																	0	
19:30																	0	
19:45																	0	
20:00																	0	
20:15																	0	
20:30																	0	
20:45																	0	
21:00																	0	
21:15																	0	
21:30																	0	
21:45																	0	
22:00																	0	
22:15																	0	
22:30																	0	
22:45																	0	
23:00																	0	
23:15																	0	
23:30																	0	
23:45																	0	
Total	0	0	0	0	0	0	0	0	0	1	2	0	0	1	0	0	4	
AM Peak Hr:																	7:00	
Pk Vol	0	0	0	0	0	0	0	0	0	0	0	0	0	0	0	0	0	
PHF	n/a	n/a	n/a	n/a	n/a	n/a	n/a	n/a	n/a	n/a	n/a	n/a	n/a	n/a	n/a	n/a	n/a	
MID Peak Hr:																	12:00	
Pk Vol	0	0	0	0	0	0	0	0	0	0	1	0	0	0	0	0	1	
PHF	n/a	n/a	n/a	n/a	n/a	n/a	n/a	n/a	n/a	n/a	0.250	n/a	n/a	n/a	n/a	n/a	0.250	
PM Peak Hr:																	16:30	
Pk Vol	0	0	0	0	0	0	0	0	0	0	0	0	0	0	0	0	0	
PHF	n/a	n/a	n/a	n/a	n/a	n/a	n/a	n/a	n/a	n/a	n/a	n/a	n/a	n/a	n/a	n/a	n/a	