

Appendix E

7th Avenue Existing Traffic Counts

Intersection ID: 1805124
Count Date: 11/27/2018

N 7TH AVE & W MCDOWELL RD

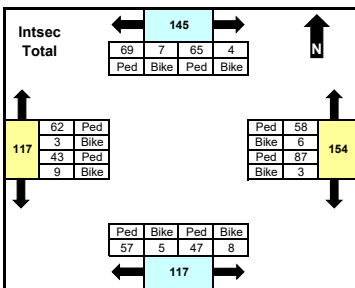
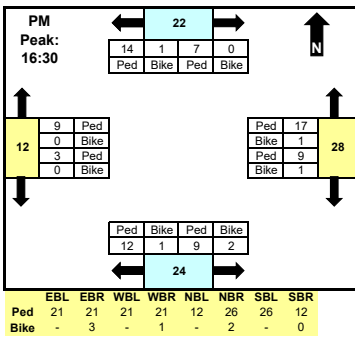
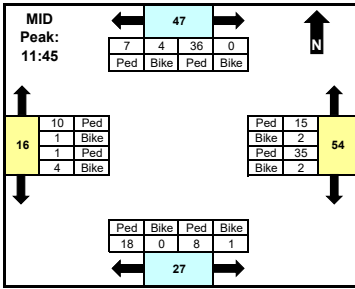
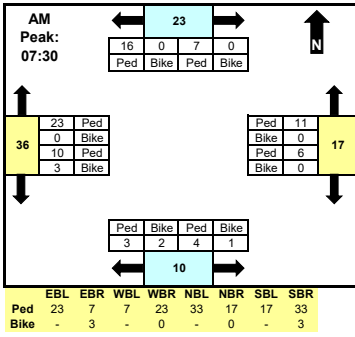

	North		East		South		West		Total
	CW	CCW	CW	CCW	CW	CCW	CW	CCW	
AM	7	16	6	11	5	5	23	13	86
MID	36	11	37	17	18	9	11	5	144
PM	7	15	10	18	13	11	9	3	86
Total	69	76	90	64	62	55	65	52	533

CW = Clockwise
CCW = Counter-clockwise

Comments

Unless shown otherwise, MID period defined as 10:00 AM - 2:00 PM. Crosswalk peaks defined based on total intersection volume for all vehicle types.

Time	North Leg		East Leg		South Leg		West Leg		INTSEC	TOTAL							
	CW	CCW	CW	CCW	CW	CCW	CW	CCW									
0:00										0							
0:15										0							
0:30										0							
0:45										0							
1:00										0							
1:15										0							
1:30										0							
1:45										0							
2:00										0							
2:15										0							
2:30										0							
2:45										0							
3:00										0							
3:15										0							
3:30										0							
3:45										0							
4:00										0							
4:15										0							
4:30										0							
4:45										0							
5:00										0							
5:15										0							
5:30										0							
5:45										0							
6:00										0							
6:15										0							
6:30	1	0	0	0	1	0	0	0	1	0							
6:45	1	0	0	0	1	0	0	0	2	0							
7:00	0	0	4	0	2	0	1	0	1	0							
7:15	0	1	2	0	1	0	0	1	2	0							
7:30	1	0	5	0	0	2	0	1	4	0							
7:45	2	0	0	0	2	0	0	1	2	0							
8:00	1	0	9	0	3	0	6	0	2	0							
8:15	3	0	2	0	1	0	3	0	0	1							
8:30										0							
8:45										0							
9:00										0							
9:15										0							
9:30										0							
9:45										0							
10:00										0							
10:15										0							
10:30										0							
10:45										0							
11:00	3	1	3	0	2	0	2	0	0	12							
11:15	2	0	9	0	2	0	2	0	1	0							
11:30	1	0	1	0	4	0	0	0	2	1							
11:45	10	0	1	1	2	1	0	0	2	0							
12:00	19	0	1	0	15	0	7	1	1	0							
12:15	6	0	3	3	7	0	3	1	9	0							
12:30	1	0	2	0	11	1	5	0	6	0							
12:45	2	0	3	0	10	0	3	0	4	0							
13:00										0							
13:15										0							
13:30										0							
13:45										0							
14:00										0							
14:15										0							
14:30										0							
14:45										0							
15:00										0							
15:15										0							
15:30										0							
15:45	1	2	3	0	6	0	0	0	3	0							
16:00	0	0	2	0	3	0	6	0	3	0							
16:15	1	0	3	1	1	0	5	0	4	0							
16:30	2	0	4	1	1	4	0	1	0	4							
16:45	2	0	5	0	1	0	3	0	2	0							
17:00	2	0	2	0	6	0	5	1	5	1							
17:15	2	0	2	2	4	0	1	0	1	0							
17:30	2	0	2	2	4	0	1	0	2	1							
17:45	2	0	3	0	1	0	0	0	4	1							
18:00										0							
18:15										0							
18:30										0							
18:45										0							
19:00										0							
19:15										0							
19:30										0							
19:45										0							
20:00										0							
20:15										0							
20:30										0							
20:45										0							
21:00										0							
21:15										0							
21:30										0							
21:45										0							
22:00										0							
22:15										0							
22:30										0							
22:45										0							
23:00										0							
23:15										0							
23:30										0							
23:45										0							
Total	65	4	69	7	87	3	58	6	57	5	47	8	62	3	43	9	533
AM Peak Hr:																	7:30
PK Vol	7	0	16	0	6	0	11	0	3	2	4	1	23	0	10	3	86
MID Peak Hr:																	11:45
PK Vol	36	0	7	4	35	2	15	2	18	0	8	1	10	1	1	4	144
PM Peak Hr:																	16:30
PK Vol	7	0	14	1	9	1	17	1	12	1	9	2	9	0	3	0	85

Intersection ID: 1805124
Count Date: 11/27/2018

N 7TH AVE & W MCDOWELL RD

From North (SB) From East (WB) From South (NB) From West (EB)
N 7TH AVE W MCDOWELL RD N 7TH AVE W MCDOWELL RD INTSEC

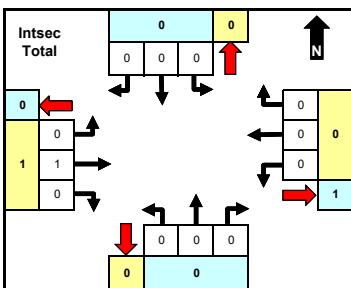
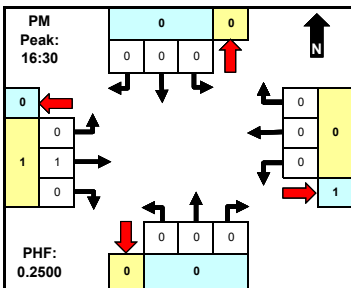
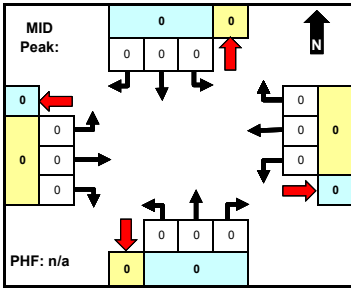
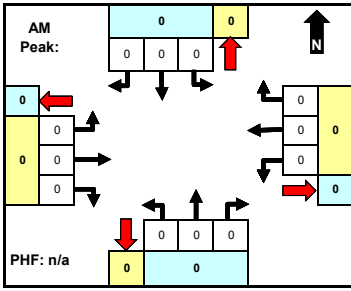

	North		East		South		West		Total
	App	Dep	App	Dep	App	Dep	App	Dep	
AM	0	0	0	0	0	0	0	0	0
MID	0	0	0	0	0	0	0	0	0
PM	0	0	0	1	0	0	1	0	1
Total	0	0	0	1	0	0	1	0	1

Comments

Unless shown otherwise, MID period defined as 10:00 AM - 2:00 PM. Peaks defined based on total intersection volume for all vehicle types.

Time	LT	Thru	RT	U	LT	Thru	RT	U	LT	Thru	RT	U	LT	Thru	RT	U	TOTAL
0:00																	0
0:15																	0
0:30																	0
0:45																	0
1:00																	0
1:15																	0
1:30																	0
1:45																	0
2:00																	0
2:15																	0
2:30																	0
2:45																	0
3:00																	0
3:15																	0
3:30																	0
3:45																	0
4:00																	0
4:15																	0
4:30																	0
4:45																	0
5:00																	0
5:15																	0
5:30																	0
5:45																	0
6:00																	0
6:15																	0
6:30	0	0	0	0	0	0	0	0	0	0	0	0	0	0	0	0	0
6:45	0	0	0	0	0	0	0	0	0	0	0	0	0	0	0	0	0
7:00	0	0	0	0	0	0	0	0	0	0	0	0	0	0	0	0	0
7:15	0	0	0	0	0	0	0	0	0	0	0	0	0	0	0	0	0
7:30	0	0	0	0	0	0	0	0	0	0	0	0	0	0	0	0	0
7:45	0	0	0	0	0	0	0	0	0	0	0	0	0	0	0	0	0
8:00	0	0	0	0	0	0	0	0	0	0	0	0	0	0	0	0	0
8:15	0	0	0	0	0	0	0	0	0	0	0	0	0	0	0	0	0
8:30																	0
8:45																	0
9:00																	0
9:15																	0
9:30																	0
9:45																	0
10:00																	0
10:15																	0
10:30																	0
10:45																	0
11:00	0	0	0	0	0	0	0	0	0	0	0	0	0	0	0	0	0
11:15	0	0	0	0	0	0	0	0	0	0	0	0	0	0	0	0	0
11:30	0	0	0	0	0	0	0	0	0	0	0	0	0	0	0	0	0
11:45	0	0	0	0	0	0	0	0	0	0	0	0	0	0	0	0	0
12:00	0	0	0	0	0	0	0	0	0	0	0	0	0	0	0	0	0
12:15	0	0	0	0	0	0	0	0	0	0	0	0	0	0	0	0	0
12:30	0	0	0	0	0	0	0	0	0	0	0	0	0	0	0	0	0
12:45	0	0	0	0	0	0	0	0	0	0	0	0	0	0	0	0	0
13:00																	0
13:15																	0
13:30																	0
13:45																	0
14:00																	0
14:15																	0
14:30																	0
14:45																	0
15:00																	0
15:15																	0
15:30																	0
15:45																	0
16:00	0	0	0	0	0	0	0	0	0	0	0	0	0	0	0	0	0
16:15	0	0	0	0	0	0	0	0	0	0	0	0	0	0	0	0	0
16:30	0	0	0	0	0	0	0	0	0	0	0	0	0	0	0	0	0
16:45	0	0	0	0	0	0	0	0	0	0	0	0	0	0	1	0	1
17:00	0	0	0	0	0	0	0	0	0	0	0	0	0	0	0	0	0
17:15	0	0	0	0	0	0	0	0	0	0	0	0	0	0	0	0	0
17:30	0	0	0	0	0	0	0	0	0	0	0	0	0	0	0	0	0
17:45	0	0	0	0	0	0	0	0	0	0	0	0	0	0	0	0	0
18:00																	0
18:15																	0
18:30																	0
18:45																	0
19:00																	0
19:15																	0
19:30																	0
19:45																	0
20:00																	0
20:15																	0
20:30																	0
20:45																	0
21:00																	0
21:15																	0
21:30																	0
21:45																	0
22:00																	0
22:15																	0
22:30																	0
22:45																	0
23:00																	0
23:15																	0
23:30																	0
23:45																	0
Total	0	0	0	0	0	0	0	0	0	0	0	0	0	0	1	0	1
AM Peak Hr:																	7:30
Pk Vol	0	0	0	0	0	0	0	0	0	0	0	0	0	0	0	0	0
PHF	n/a	n/a	n/a	n/a	n/a	n/a	n/a	n/a	n/a	n/a	n/a	n/a	n/a	n/a	n/a	n/a	n/a
MID Peak Hr:																	11:45
Pk Vol	0	0	0	0	0	0	0	0	0	0	0	0	0	0	0	0	0
PHF	n/a	n/a	n/a	n/a	n/a	n/a	n/a	n/a	n/a	n/a	n/a	n/a	n/a	n/a	n/a	n/a	n/a
PM Peak Hr:																	16:30
Pk Vol	0	0	0	0	0	0	0	0	0	0	0	0	0	1	0	0	1
PHF	n/a	n/a	n/a	n/a	n/a	n/a	n/a	n/a	n/a	n/a	n/a	n/a	n/a	0.250	n/a	n/a	0.250

Intersection ID: 1805123
Count Date: 11/27/2018

N 7TH AVE & W ENCANTO BLVD

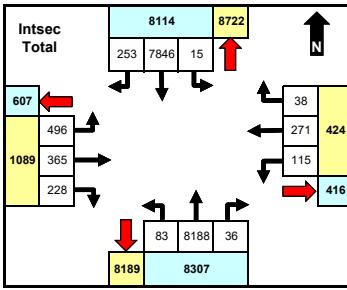
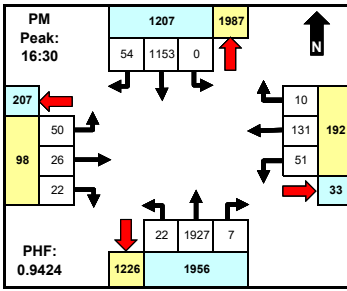
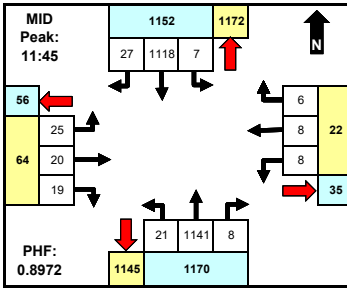
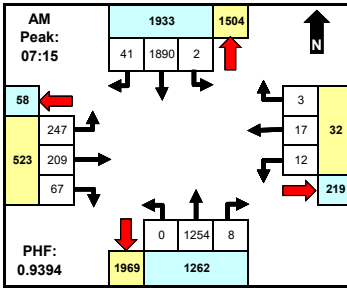

	North		East		South		West		
	App	Dep	App	Dep	App	Dep	App	Dep	Total
AM	1933	1504	32	219	1262	1969	523	58	3750
MID	1152	1172	22	35	1170	1145	64	56	2408
PM	1207	1987	192	33	1956	1226	98	207	3453
Total	8114	8722	424	416	8307	8189	1089	607	###

Comments
Unless shown otherwise, MID period defined as 10:00 AM - 2:00 PM. Peaks defined based on total intersection volume for all vehicle types.

Time	From North (SB)				From East (WB)				From South (NB)				From West (EB)				INTSEC	TOTAL
	LT	Thru	RT	U	LT	Thru	RT	U	LT	Thru	RT	U	LT	Thru	RT	U		
0:00																	0	
0:15																	0	
0:30																	0	
0:45																	0	
1:00																	0	
1:15																	0	
1:30																	0	
1:45																	0	
2:00																	0	
2:15																	0	
2:30																	0	
2:45																	0	
3:00																	0	
3:15																	0	
3:30																	0	
3:45																	0	
4:00																	0	
4:15																	0	
4:30																	0	
4:45																	0	
5:00																	0	
5:15																	0	
5:30																	0	
5:45																	0	
6:00																	0	
6:15																	0	
6:30	0	347	1	0	3	0	0	0	1	221	0	0	7	4	10	0	594	
6:45	0	427	7	0	3	0	0	0	0	267	1	0	16	13	29	0	763	
7:00	1	407	7	0	1	0	1	0	0	248	0	0	25	26	34	0	750	
7:15	1	531	7	0	3	2	1	0	0	285	0	0	37	48	27	0	941	
7:30	1	489	15	0	3	3	2	0	0	316	3	0	72	70	16	0	990	
7:45	0	462	10	0	2	6	0	0	0	383	2	0	71	54	8	0	938	
8:00	1	408	9	0	4	6	0	0	0	270	3	0	67	37	16	0	821	
8:15	1	463	8	0	1	5	1	0	0	293	0	0	43	34	10	0	859	
8:30																	0	
8:45																	0	
9:00																	0	
9:15																	0	
9:30																	0	
9:45																	0	
10:00																	0	
10:15																	0	
10:30																	0	
10:45																	0	
11:00	0	232	9	0	5	0	4	0	1	263	0	0	9	3	4	0	530	
11:15	0	250	11	0	2	1	1	0	4	318	1	0	8	4	6	0	606	
11:30	0	224	7	0	1	1	4	0	0	263	5	0	6	3	5	0	519	
11:45	1	241	8	0	6	0	2	0	7	303	2	0	5	7	6	0	588	
12:00	2	261	4	0	0	1	0	0	7	273	1	0	8	3	7	0	567	
12:15	1	357	5	0	2	2	4	0	1	285	1	0	6	3	4	0	671	
12:30	3	259	10	0	0	5	0	0	6	280	4	0	6	7	2	0	582	
12:45	3	275	7	0	1	1	0	0	3	248	3	0	6	2	4	0	553	
13:00																	0	
13:15																	0	
13:30																	0	
13:45																	0	
14:00																	0	
14:15																	0	
14:30																	0	
14:45																	0	
15:00																	0	
15:15																	0	
15:30																	0	
15:45																	0	
16:00	0	286	8	0	7	29	1	0	6	375	1	0	15	5	4	0	737	
16:15	1	308	11	0	4	27	2	0	10	502	0	0	19	6	4	0	894	
16:30	0	267	12	0	10	30	2	0	4	485	1	0	12	5	5	0	833	
16:45	0	278	11	0	9	22	2	0	2	480	1	0	9	5	7	0	826	
17:00	0	324	9	0	13	32	4	0	12	455	3	0	10	9	7	0	878	
17:15	0	284	22	0	19	47	2	0	4	507	2	0	19	7	3	0	916	
17:30	0	230	29	0	13	36	2	0	7	447	1	0	14	5	7	0	727	
17:45	0	236	26	0	3	15	3	0	8	421	1	0	6	5	3	0	721	
18:00																	0	
18:15																	0	
18:30																	0	
18:45																	0	
19:00																	0	
19:15																	0	
19:30																	0	
19:45																	0	
20:00																	0	
20:15																	0	
20:30																	0	
20:45																	0	
21:00																	0	
21:15																	0	
21:30																	0	
21:45																	0	
22:00																	0	
22:15																	0	
22:30																	0	
22:45																	0	
23:00																	0	
23:15																	0	
23:30																	0	
23:45																	0	
Total	15	7846	253	0	115	271	38	0	83	8188	36	0	496	365	228	0	17934	
AM Peak Hr:																	7:15	
Pk Vol	2	1890	41	0	12	17	3	0	0	1254	8	0	247	209	67	0	3750	
PHF	0.500	0.890	0.683	n/a	0.750	0.708	0.375	n/a	n/a	0.819	0.667	n/a	0.858	0.746	0.620	n/a	0.939	
MID Peak Hr:																	11:45	
Pk Vol	7	1118	27	0	8	8	6	0	21	1141	8	0	25	26	19	0	2408	
PHF	0.583	0.783	0.675	n/a	0.333	0.400	0.375	n/a	0.750	0.941	0.500	n/a	0.781	0.714	0.679	n/a	0.897	
PM Peak Hr:																	16:30	
Pk Vol	0	1163	54	0	51	131	10	0	22	1927	7	0	50	26	22	0	3453	
PHF	n/a	0.890	0.614	n/a	0.671	0.697	0.625	n/a	0.458	0.950	0.583	n/a	0.658	0.722	0.786	n/a	0.942	



Intersection ID: 1805123
Count Date: 11/27/2018

N 7TH AVE & W ENCANTO BLVD

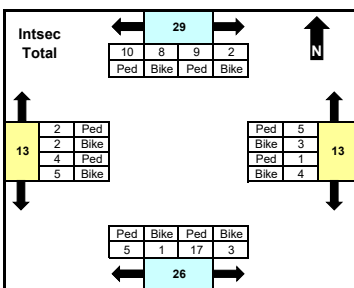
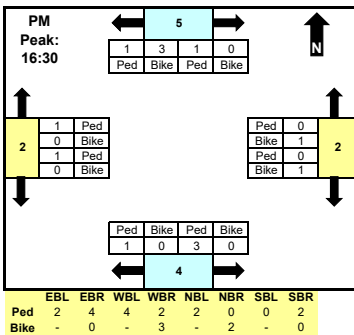
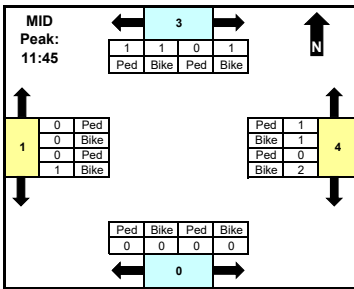
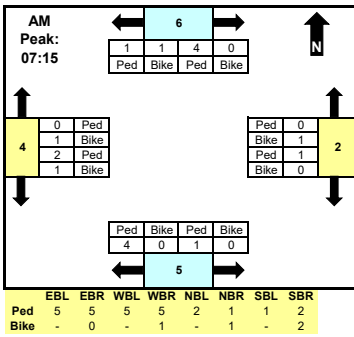

	North		East		South		West		Total
	CW	CCW	CW	CCW	CW	CCW	CW	CCW	
AM	4	2	1	1	4	1	1	3	17
MID	1	2	2	2	0	0	0	1	8
PM	1	4	1	1	1	3	1	1	13
Total	11	18	5	8	6	20	4	9	81

CW = Clockwise
CCW = Counter-clockwise

Comments

Unless shown otherwise, MID period defined as 10:00 AM - 2:00 PM. Crosswalk peaks defined based on total intersection volume for all vehicle types.

Time	North Leg		East Leg		South Leg		West Leg		INTSEC	TOTAL							
	CW	CCW	CW	CCW	CW	CCW	CW	CCW									
0:00										0							
0:15										0							
0:30										0							
0:45										0							
1:00										0							
1:15										0							
1:30										0							
1:45										0							
2:00										0							
2:15										0							
2:30										0							
2:45										0							
3:00										0							
3:15										0							
3:30										0							
3:45										0							
4:00										0							
4:15										0							
4:30										0							
4:45										0							
5:00										0							
5:15										0							
5:30										0							
5:45										0							
6:00										0							
6:15										0							
6:30	0	0	1	0	0	0	1	0	0	0							
6:45	0	0	0	0	0	0	1	0	0	0							
7:00	1	0	0	0	0	0	0	0	0	0							
7:15	0	0	0	0	0	0	1	4	0	1							
7:30	4	0	1	0	0	0	0	0	0	1							
7:45	0	0	0	1	0	0	0	0	0	1							
8:00	0	0	0	1	0	0	0	0	0	0							
8:15	0	0	1	0	0	0	0	0	0	0							
8:30										0							
8:45										0							
9:00										0							
9:15										0							
9:30										0							
9:45										0							
10:00										0							
10:15										0							
10:30										0							
10:45										0							
11:00	0	0	0	0	0	0	0	0	0	1							
11:15	0	0	0	1	0	0	1	0	0	0							
11:30	0	0	0	0	0	0	0	0	0	0							
11:45	0	1	0	0	0	1	0	0	0	0							
12:00	0	0	1	0	0	0	1	1	0	0							
12:15	0	0	0	1	0	0	0	0	0	1							
12:30	0	0	0	0	0	1	0	0	0	0							
12:45	1	0	0	0	0	0	0	0	0	0							
13:00										0							
13:15										0							
13:30										0							
13:45										0							
14:00										0							
14:15										0							
14:30										0							
14:45										0							
15:00										0							
15:15										0							
15:30										0							
15:45	0	0	0	0	0	0	0	0	0	0							
16:00	2	1	1	0	0	0	1	1	0	0							
16:15	0	0	0	1	0	0	0	0	0	0							
16:30	0	0	0	1	0	0	0	0	0	0							
16:45	0	0	1	0	0	1	0	0	0	0							
17:00	1	0	0	1	0	0	0	1	0	0							
17:15	0	0	0	1	0	0	1	0	1	0							
17:30	0	0	2	2	0	1	0	0	1	2							
17:45	0	0	2	0	0	0	1	1	0	0							
18:00										0							
18:15										0							
18:30										0							
18:45										0							
19:00										0							
19:15										0							
19:30										0							
19:45										0							
20:00										0							
20:15										0							
20:30										0							
20:45										0							
21:00										0							
21:15										0							
21:30										0							
21:45										0							
22:00										0							
22:15										0							
22:30										0							
22:45										0							
23:00										0							
23:15										0							
23:30										0							
23:45										0							
Total	9	2	10	8	1	4	5	3	5	1	17	3	2	2	4	5	81
AM Peak Hr:																	7:15
PK Vol	4	0	1	1	1	0	0	1	4	0	1	0	0	1	2	1	17
MID Peak Hr:																	11:45
PK Vol	0	1	1	1	0	2	1	1	0	0	0	0	0	0	0	1	8
PM Peak Hr:																	16:30
PK Vol	1	0	1	3	0	1	0	1	1	0	3	0	1	0	1	0	13

Intersection ID: 1805123
Count Date: 11/27/2018

N 7TH AVE & W ENCANTO BLVD

From North (SB) From East (WB) From South (NB) From West (EB)
N 7TH AVE W ENCANTO BLVD N 7TH AVE W ENCANTO BLVD INTSEC

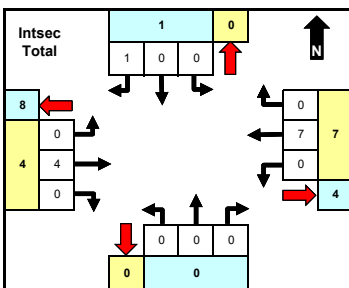
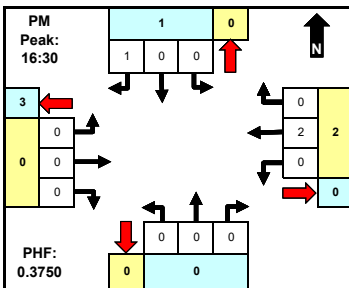
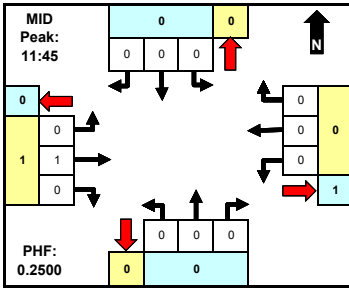
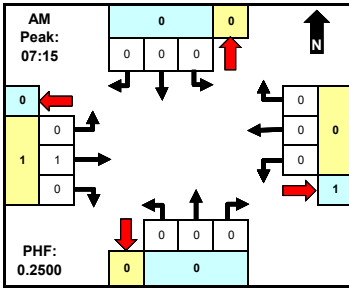

	North		East		South		West		Total
	App	Dep	App	Dep	App	Dep	App	Dep	
AM	0	0	0	1	0	0	1	0	1
MID	0	0	0	1	0	0	1	0	1
PM	1	0	2	0	0	0	3	3	3
Total	1	0	2	2	0	0	5	3	12

Comments

Unless shown otherwise, MID period defined as 10:00 AM - 2:00 PM. Peaks defined based on total intersection volume for all vehicle types.

Time	From North (SB)				From East (WB)				From South (NB)				From West (EB)				TOTAL
	LT	Thru	RT	U	LT	Thru	RT	U	LT	Thru	RT	U	LT	Thru	RT	U	
0:00																	0
0:15																	0
0:30																	0
0:45																	0
1:00																	0
1:15																	0
1:30																	0
1:45																	0
2:00																	0
2:15																	0
2:30																	0
2:45																	0
3:00																	0
3:15																	0
3:30																	0
3:45																	0
4:00																	0
4:15																	0
4:30																	0
4:45																	0
5:00																	0
5:15																	0
5:30																	0
5:45																	0
6:00																	0
6:15																	0
6:30	0	0	0	0	0	0	0	0	0	0	0	0	0	0	0	0	
6:45	0	0	0	0	0	0	0	0	0	0	0	0	0	2	0	0	2
7:00	0	0	0	0	0	0	0	0	0	0	0	0	0	0	0	0	0
7:15	0	0	0	0	0	0	0	0	0	0	0	0	0	0	0	0	0
7:30	0	0	0	0	0	0	0	0	0	0	0	0	0	0	0	0	0
7:45	0	0	0	0	0	0	0	0	0	0	0	0	0	0	1	0	1
8:00	0	0	0	0	0	0	0	0	0	0	0	0	0	0	0	0	0
8:15	0	0	0	0	0	0	0	0	0	0	0	0	0	0	0	0	0
8:30																	0
8:45																	0
9:00																	0
9:15																	0
9:30																	0
9:45																	0
10:00																	0
10:15																	0
10:30																	0
10:45																	0
11:00	0	0	0	0	0	0	0	0	0	0	0	0	0	0	0	0	0
11:15	0	0	0	0	0	0	0	0	0	0	0	0	0	0	0	0	0
11:30	0	0	0	0	0	0	0	0	0	0	0	0	0	0	0	0	0
11:45	0	0	0	0	0	0	0	0	0	0	0	0	0	0	0	0	0
12:00	0	0	0	0	0	0	0	0	0	0	0	0	0	1	0	0	1
12:15	0	0	0	0	0	0	0	0	0	0	0	0	0	0	0	0	0
12:30	0	0	0	0	0	0	0	0	0	0	0	0	0	0	0	0	0
12:45	0	0	0	0	0	0	0	0	0	0	0	0	0	0	0	0	0
13:00																	0
13:15																	0
13:30																	0
13:45																	0
14:00																	0
14:15																	0
14:30																	0
14:45																	0
15:00																	0
15:15																	0
15:30																	0
15:45																	0
16:00	0	0	0	0	0	1	0	0	0	0	0	0	0	0	0	0	1
16:15	0	0	0	0	0	0	0	0	0	0	0	0	0	0	0	0	0
16:30	0	0	0	1	0	0	1	0	0	0	0	0	0	0	0	0	2
16:45	0	0	0	0	0	0	0	0	0	0	0	0	0	0	0	0	0
17:00	0	0	0	0	0	0	0	0	0	0	0	0	0	0	0	0	0
17:15	0	0	0	0	0	0	1	0	0	0	0	0	0	0	0	0	1
17:30	0	0	0	0	0	0	4	0	0	0	0	0	0	0	0	0	4
17:45	0	0	0	0	0	0	0	0	0	0	0	0	0	0	0	0	0
18:00																	0
18:15																	0
18:30																	0
18:45																	0
19:00																	0
19:15																	0
19:30																	0
19:45																	0
20:00																	0
20:15																	0
20:30																	0
20:45																	0
21:00																	0
21:15																	0
21:30																	0
21:45																	0
22:00																	0
22:15																	0
22:30																	0
22:45																	0
23:00																	0
23:15																	0
23:30																	0
23:45																	0
Total	0	0	1	0	0	7	0	0	0	0	0	0	4	0	0	0	12
AM Peak Hr:																	7:15
Pk Vol	0	0	0	0	0	0	0	0	0	0	0	0	1	0	0	0	1
PHF	n/a	n/a	n/a	n/a	n/a	n/a	n/a	n/a	n/a	n/a	n/a	n/a	0.250	n/a	n/a	n/a	0.250
MID Peak Hr:																	11:45
Pk Vol	0	0	0	0	0	0	0	0	0	0	0	0	1	0	0	0	1
PHF	n/a	n/a	n/a	n/a	n/a	n/a	n/a	n/a	n/a	n/a	n/a	n/a	0.250	n/a	n/a	n/a	0.250
PM Peak Hr:																	16:30
Pk Vol	0	0	1	0	0	2	0	0	0	0	0	0	0	0	0	0	3
PHF	n/a	n/a	0.250	n/a	n/a	0.500	n/a	n/a	n/a	n/a	n/a	n/a	n/a	n/a	n/a	n/a	0.375

Intersection ID: 1805122
Count Date: 11/27/2018

N 7TH AVE & W THOMAS RD

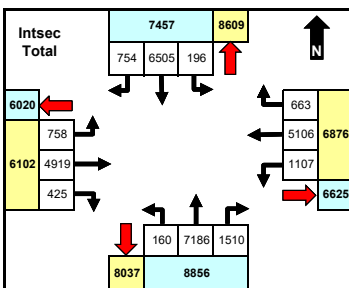
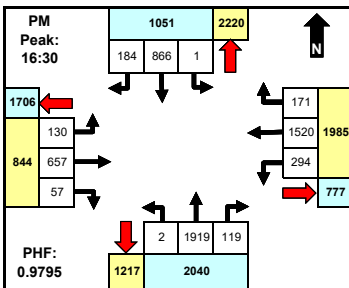
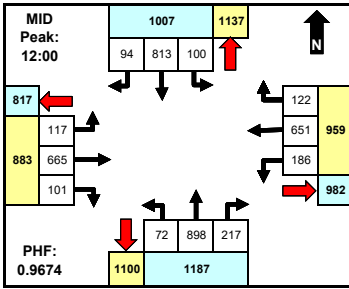
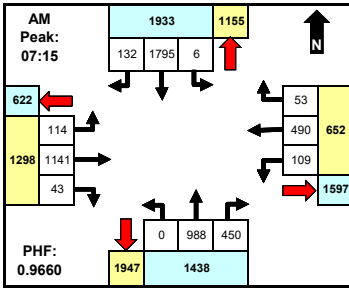

	North		East		South		West		Total
	App	Dep	App	Dep	App	Dep	App	Dep	
AM	1933	1155	652	1597	1438	1947	1298	622	5321
MID	1007	1137	959	982	1187	1100	883	817	4036
PM	1051	2220	1985	777	2040	1217	844	1706	5920
Total	7457	8609	6876	6625	8856	8037	6102	6020	##

Comments
Unless shown otherwise, MID period defined as 10:00 AM - 2:00 PM. Peaks defined based on total intersection volume for all vehicle types.

Time	From North (SB) N 7TH AVE				From East (WB) W THOMAS RD				From South (NB) N 7TH AVE				From West (EB) W THOMAS RD				INTSEC	TOTAL	
	LT	Thru	RT	U	LT	Thru	RT	U	LT	Thru	RT	U	LT	Thru	RT	U			
	0:00																		
0:15																		0	
0:30																		0	
0:45																		0	
1:00																		0	
1:15																		0	
1:30																		0	
1:45																		0	
2:00																		0	
2:15																		0	
2:30																		0	
2:45																		0	
3:00																		0	
3:15																		0	
3:30																		0	
3:45																		0	
4:00																		0	
4:15																		0	
4:30																		0	
4:45																		0	
5:00																		0	
5:15																		0	
5:30																		0	
5:45																		0	
6:00																		0	
6:15																		0	
6:30	0	308	17	0	15	65	8	0	0	167	71	0	24	302	26	0	1003		
6:45	0	372	31	0	16	85	5	0	0	191	70	0	59	306	25	0	1160		
7:00	0	421	25	0	15	73	18	0	0	194	86	0	34	281	10	0	1157		
7:15	2	462	30	0	25	122	13	0	0	215	100	0	30	292	15	0	1306		
7:30	0	490	37	0	31	115	14	0	0	259	119	0	29	274	10	0	1377		
7:45	1	411	28	0	26	134	15	0	0	291	116	0	32	305	10	0	1389		
8:00	3	432	37	0	27	119	11	0	0	224	115	0	23	270	8	0	1269		
8:15	1	397	34	1	12	122	18	0	0	223	102	0	30	283	30	0	1253		
8:30																		0	
8:45																		0	
9:00																		0	
9:15																		0	
9:30																		0	
9:45																		0	
10:00																		0	
10:15																		0	
10:30																		0	
10:45																		0	
11:00	23	172	16	0	53	157	17	0	19	200	67	0	28	146	17	0	915		
11:15	19	190	20	0	48	170	23	0	23	240	62	0	29	141	28	0	993		
11:30	31	162	31	0	48	170	24	0	20	188	70	0	35	139	23	0	941		
11:45	12	178	23	0	52	166	37	0	19	239	59	0	23	158	23	0	989		
12:00	26	202	25	0	47	146	23	0	20	231	54	0	31	156	26	0	986		
12:15	19	193	26	0	44	181	29	0	13	238	65	0	20	168	17	0	1013		
12:30	32	190	21	0	57	182	31	0	24	217	57	0	34	168	30	0	1043		
12:45	24	228	22	0	38	142	39	0	15	212	41	0	32	173	28	0	994		
13:00																		0	
13:15																		0	
13:30																		0	
13:45																		0	
14:00																		0	
14:15																		0	
14:30																		0	
14:45																		0	
15:00																		0	
15:15																		0	
15:30																		0	
15:45																		0	
16:00	2	236	48	0	69	362	52	0	2	404	35	0	32	174	9	0	1425		
16:15	0	211	35	0	78	340	35	0	0	476	34	0	37	171	17	0	1434		
16:30	0	210	41	0	68	423	40	0	0	454	33	0	21	177	9	0	1476		
16:45	1	204	38	0	69	362	41	0	1	495	31	0	37	160	13	0	1452		
17:00	0	233	43	0	84	366	48	0	0	473	23	0	39	150	22	0	1481		
17:15	0	219	62	0	73	369	42	0	1	497	32	0	33	170	13	0	1511		
17:30	0	191	36	1	57	423	35	0	1	473	30	0	35	179	10	0	1471		
17:45	1	193	28	0	55	312	45	0	2	386	38	0	31	176	6	0	1273		
18:00																		0	
18:15																		0	
18:30																		0	
18:45																		0	
19:00																		0	
19:15																		0	
19:30																		0	
19:45																		0	
20:00																		0	
20:15																		0	
20:30																		0	
20:45																		0	
21:00																		0	
21:15																		0	
21:30																		0	
21:45																		0	
22:00																		0	
22:15																		0	
22:30																		0	
22:45																		0	
23:00																		0	
23:15																		0	
23:30																		0	
23:45																		0	
Total	196	6505	754	2	1107	5106	663	0	160	7186	1510	0	758	4919	425	0	29291		
AM Peak Hr:																		7:15	
Pk Vol	6	1795	132	0	109	490	53	0	0	988	450	0	114	1141	43	0	5321		
PHF	0.500	0.916	0.892	n/a	0.879	0.914	0.883	n/a	n/a	0.849	0.945	n/a	0.891	0.935					

Intersection ID: 1805122
Count Date: 11/27/2018

N 7TH AVE & W THOMAS RD

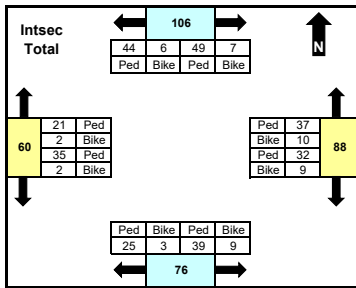
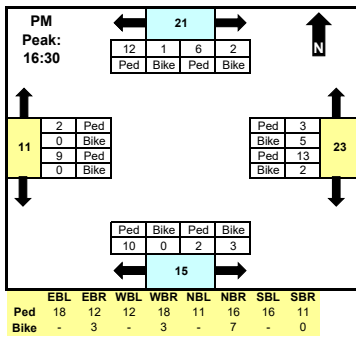
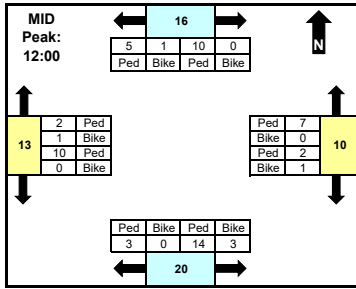
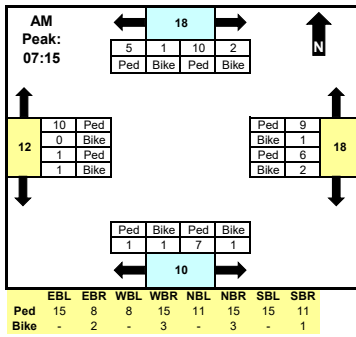

	North		East		South		West		Total
	CW	CCW	CW	CCW	CW	CCW	CW	CCW	
AM	12	6	8	10	2	8	10	2	58
MID	10	6	3	7	3	17	3	10	59
PM	8	13	15	8	10	5	2	9	70
Total	56	50	41	47	28	48	23	37	330

CW = Clockwise
CCW = Counter-clockwise

Comments

Unless shown otherwise, MID period defined as 10:00 AM - 2:00 PM. Crosswalk peaks defined based on total intersection volume for all vehicle types.

Time	North Leg		East Leg		South Leg		West Leg		INTSEC	TOTAL							
	CW	CCW	CW	CCW	CW	CCW	CW	CCW									
0:00										0							
0:15										0							
0:30										0							
0:45										0							
1:00										0							
1:15										0							
1:30										0							
1:45										0							
2:00										0							
2:15										0							
2:30										0							
2:45										0							
3:00										0							
3:15										0							
3:30										0							
3:45										0							
4:00										0							
4:15										0							
4:30										0							
4:45										0							
5:00										0							
5:15										0							
5:30										0							
5:45										0							
6:00										0							
6:15										0							
6:30	1	0	0	0	1	0	1	0	0	0							
6:45	1	0	2	0	1	0	1	0	0	0							
7:00	1	0	2	0	1	0	1	0	0	0							
7:15	4	1	0	1	1	0	2	0	0	0							
7:30	2	1	1	0	2	2	1	0	0	0							
7:45	2	0	3	0	3	0	1	0	1	0							
8:00	2	0	1	0	2	0	0	1	2	0							
8:15	0	0	4	1	1	0	3	0	2	0							
8:30										0							
8:45										0							
9:00										0							
9:15										0							
9:30										0							
9:45										0							
10:00										0							
10:15										0							
10:30										0							
10:45										0							
11:00	0	0	3	0	2	0	0	0	2	0							
11:15	3	0	1	0	2	0	2	0	1	0							
11:30	4	0	5	2	1	0	2	2	1	0							
11:45	5	1	2	0	0	1	3	1	0	0							
12:00	3	0	1	1	1	0	0	2	0	0							
12:15	3	0	1	0	1	0	5	0	1	0							
12:30	4	0	1	0	1	0	0	3	0	0							
12:45	0	0	2	0	0	2	0	0	0	0							
13:00										0							
13:15										0							
13:30										0							
13:45										0							
14:00										0							
14:15										0							
14:30										0							
14:45										0							
15:00										0							
15:15										0							
15:30										0							
15:45										0							
16:00	4	2	0	0	1	2	2	0	0	0							
16:15	2	0	1	0	1	0	2	1	0	0							
16:30	2	1	0	1	3	0	1	3	2	0							
16:45	1	0	3	0	1	1	1	0	0	0							
17:00	1	0	3	0	5	1	0	0	5	0							
17:15	2	1	6	0	4	0	1	2	3	0							
17:30	2	0	1	0	0	1	1	0	1	0							
17:45	0	0	1	0	0	0	0	1	0	0							
18:00										0							
18:15										0							
18:30										0							
18:45										0							
19:00										0							
19:15										0							
19:30										0							
19:45										0							
20:00										0							
20:15										0							
20:30										0							
20:45										0							
21:00										0							
21:15										0							
21:30										0							
21:45										0							
22:00										0							
22:15										0							
22:30										0							
22:45										0							
23:00										0							
23:15										0							
23:30										0							
23:45										0							
Total	49	7	44	6	32	9	37	10	25	3	39	9	21	2	35	2	330
AM Peak Hr:																	7:15
PK Vol	10	2	5	1	6	2	9	1	1	1	7	1	10	0	1	1	58
MID Peak Hr:																	12:00
PK Vol	10	0	5	1	2	1	7	0	3	0	14	3	2	1	10	0	59
PM Peak Hr:																	16:30
PK Vol	6	2	12	1	13	2	3	5	10	0	2	3	2	0	9	0	70

Intersection ID: 1805122
Count Date: 11/27/2018

N 7TH AVE & W THOMAS RD

From North (SB) From East (WB) From South (NB) From West (EB) INTSEC
N 7TH AVE W THOMAS RD N 7TH AVE W THOMAS RD

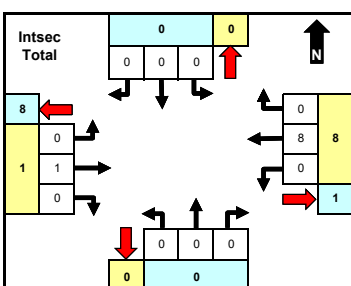
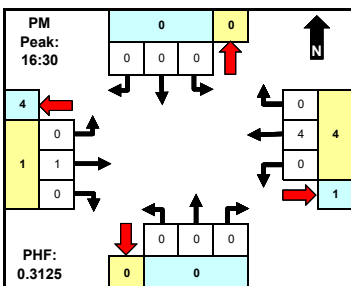
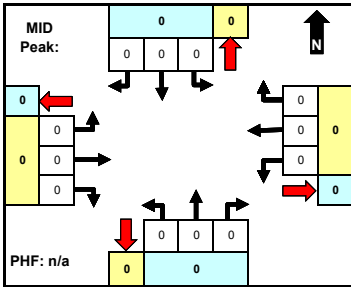
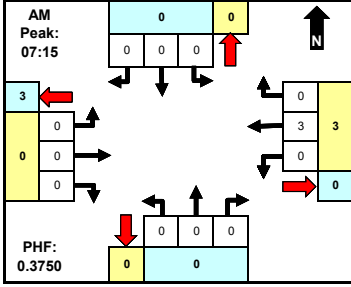

	North		East		South		West		Total
	App	Dep	App	Dep	App	Dep	App	Dep	
AM	0	0	3	0	0	0	0	0	3
MID	0	0	0	0	0	0	0	0	0
PM	0	0	4	1	0	0	1	1	6
Total	0	0	7	1	0	0	1	1	9

Comments
Unless shown otherwise, MID period defined as 10:00 AM - 2:00 PM. Peaks defined based on total intersection volume for all vehicle types.

Time	From North (SB)				From East (WB)				From South (NB)				From West (EB)				TOTAL
	LT	Thru	RT	U	LT	Thru	RT	U	LT	Thru	RT	U	LT	Thru	RT	U	
0:00																	0
0:15																	0
0:30																	0
0:45																	0
1:00																	0
1:15																	0
1:30																	0
1:45																	0
2:00																	0
2:15																	0
2:30																	0
2:45																	0
3:00																	0
3:15																	0
3:30																	0
3:45																	0
4:00																	0
4:15																	0
4:30																	0
4:45																	0
5:00																	0
5:15																	0
5:30																	0
5:45																	0
6:00																	0
6:15																	0
6:30	0	0	0	0	0	0	0	0	0	0	0	0	0	0	0	0	0
6:45	0	0	0	0	0	0	0	0	0	0	0	0	0	0	0	0	0
7:00	0	0	0	0	0	0	0	0	0	0	0	0	0	0	0	0	0
7:15	0	0	0	0	0	0	0	0	0	0	0	0	0	0	0	0	0
7:30	0	0	0	0	0	0	0	0	0	0	0	0	0	0	0	0	0
7:45	0	0	0	0	0	0	0	0	0	0	0	0	0	0	0	0	0
8:00	0	0	0	0	0	0	0	0	0	0	0	0	0	0	0	0	0
8:15	0	0	0	0	0	0	0	0	0	0	0	0	0	0	0	0	0
8:30																	0
8:45																	0
9:00																	0
9:15																	0
9:30																	0
9:45																	0
10:00																	0
10:15																	0
10:30																	0
10:45																	0
11:00	0	0	0	0	0	0	0	0	0	0	0	0	0	0	0	0	0
11:15	0	0	0	0	0	0	0	0	0	0	0	0	0	0	0	0	0
11:30	0	0	0	0	0	0	0	0	0	0	0	0	0	0	0	0	0
11:45	0	0	0	0	0	0	0	0	0	0	0	0	0	0	0	0	0
12:00	0	0	0	0	0	0	0	0	0	0	0	0	0	0	0	0	0
12:15	0	0	0	0	0	0	0	0	0	0	0	0	0	0	0	0	0
12:30	0	0	0	0	0	0	0	0	0	0	0	0	0	0	0	0	0
12:45	0	0	0	0	0	0	0	0	0	0	0	0	0	0	0	0	0
13:00																	0
13:15																	0
13:30																	0
13:45																	0
14:00																	0
14:15																	0
14:30																	0
14:45																	0
15:00																	0
15:15																	0
15:30																	0
15:45																	0
16:00	0	0	0	0	0	0	0	0	0	0	0	0	0	0	0	0	0
16:15	0	0	0	0	0	0	0	0	0	0	0	0	0	0	0	0	0
16:30	0	0	0	0	0	0	0	0	0	0	0	0	0	0	0	0	0
16:45	0	0	0	0	0	0	0	0	0	0	0	0	0	0	0	0	0
17:00	0	0	0	0	0	0	0	0	0	0	0	0	0	0	0	0	0
17:15	0	0	0	0	0	0	0	0	0	0	0	0	0	0	0	0	0
17:30	0	0	0	0	0	0	0	0	0	0	0	0	0	0	0	0	0
17:45	0	0	0	0	0	0	0	0	0	0	0	0	0	0	0	0	0
18:00																	0
18:15																	0
18:30																	0
18:45																	0
19:00																	0
19:15																	0
19:30																	0
19:45																	0
20:00																	0
20:15																	0
20:30																	0
20:45																	0
21:00																	0
21:15																	0
21:30																	0
21:45																	0
22:00																	0
22:15																	0
22:30																	0
22:45																	0
23:00																	0
23:15																	0
23:30																	0
23:45																	0
Total	0	0	0	0	0	0	0	0	0	0	0	0	0	0	0	0	9
AM Peak Hr:																	7:15
Pk Vol	0	0	0	0	0	0	3	0	0	0	0	0	0	0	0	0	3
PHF	n/a	n/a	n/a	n/a	n/a	n/a	0.375	n/a	n/a	n/a	n/a	n/a	n/a	n/a	n/a	n/a	0.375
MID Peak Hr:																	12:00
Pk Vol	0	0	0	0	0	0	0	0	0	0	0	0	0	0	0	0	0
PHF	n/a	n/a	n/a	n/a	n/a	n/a	n/a	n/a	n/a	n/a	n/a	n/a	n/a	n/a	n/a	n/a	n/a
PM Peak Hr:																	16:30
Pk Vol	0	0	0	0	0	0	4	0	0	0	0	0	0	0	0	0	4
PHF	n/a	n/a	n/a	n/a	n/a	n/a	0.250	n/a	n/a	n/a	n/a	n/a	n/a	n/a	n/a	n/a	0.313

Intersection ID: 1805409
Count Date: 11/27/2018

N 7TH AVE & W EARLL DR

From North (SB) From East (WB) From South (NB) From West (EB)
N 7TH AVE W EARLL DR N 7TH AVE W EARLL DR INTSEC

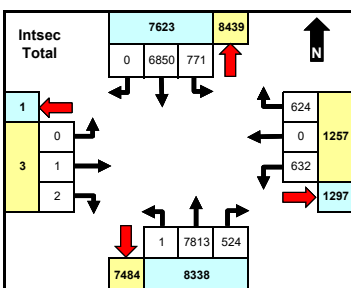
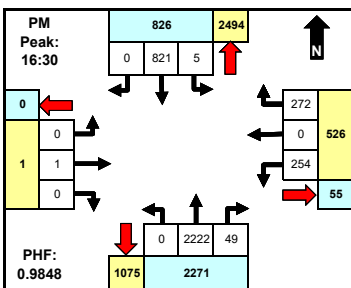
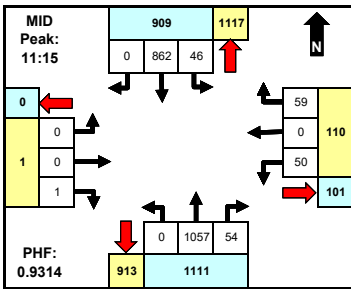
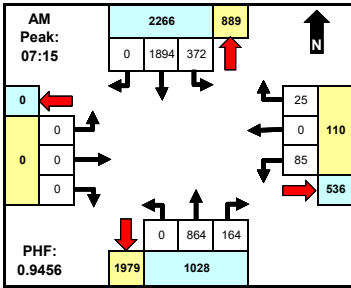

	North		East		South		West		Total
	App	Dep	App	Dep	App	Dep	App	Dep	
AM	2266	889	110	536	1028	1979	0	0	3404
MID	909	1117	110	101	1111	913	1	0	2131
PM	826	2494	526	55	2271	1075	1	0	3624
Total	7623	8439	1257	1297	8338	7484	3	1	###

Comments

Unless shown otherwise, MID period defined as 10:00 AM - 2:00 PM. Peaks defined based on total intersection volume for all vehicle types.

Time	LT	Thru	RT	U	LT	Thru	RT	U	LT	Thru	RT	U	LT	Thru	RT	U	TOTAL
0:00																	0
0:15																	0
0:30																	0
0:45																	0
1:00																	0
1:15																	0
1:30																	0
1:45																	0
2:00																	0
2:15																	0
2:30																	0
2:45																	0
3:00																	0
3:15																	0
3:30																	0
3:45																	0
4:00																	0
4:15																	0
4:30																	0
4:45																	0
5:00																	0
5:15																	0
5:30																	0
5:45																	0
6:00																	0
6:15																	0
6:30	69	308	0	0	6	0	5	0	0	95	29	0	0	0	0	0	512
6:45	74	409	0	0	14	0	4	0	1	166	50	0	0	0	1	0	719
7:00	70	451	0	1	12	0	7	0	0	193	37	0	0	0	0	0	771
7:15	72	510	0	0	15	0	4	0	0	191	35	0	0	0	0	0	827
7:30	98	496	0	0	29	0	7	0	0	234	36	0	0	0	0	0	900
7:45	124	440	0	0	23	0	7	0	0	259	45	0	0	0	0	0	838
8:00	78	448	0	0	18	0	7	0	0	180	48	0	0	0	0	0	779
8:15	89	440	0	0	13	0	8	0	0	202	41	0	0	0	0	0	793
8:30																	0
8:45																	0
9:00																	0
9:15																	0
9:30																	0
9:45																	0
10:00																	0
10:15																	0
10:30																	0
10:45																	0
11:00	8	208	0	0	10	0	14	0	0	221	13	0	0	0	0	0	474
11:15	13	228	0	0	8	0	16	0	0	263	11	0	0	0	0	0	539
11:30	5	198	0	0	11	0	14	0	0	234	11	0	0	0	0	0	473
11:45	13	194	0	0	19	0	10	1	0	291	19	0	0	0	0	0	547
12:00	15	242	0	1	12	0	19	0	0	269	13	0	0	0	1	0	572
12:15	8	218	0	0	9	0	12	0	0	259	24	0	0	0	0	0	530
12:30	12	142	0	0	16	0	13	0	0	256	15	0	0	0	0	0	454
12:45	13	249	0	0	11	0	16	0	0	264	12	0	0	0	0	0	565
13:00																	0
13:15																	0
13:30																	0
13:45																	0
14:00																	0
14:15																	0
14:30																	0
14:45																	0
15:00																	0
15:15																	0
15:30																	0
15:45																	0
16:00	3	239	0	0	49	0	49	0	0	478	11	0	0	0	0	0	829
16:15	1	218	0	0	41	0	62	0	0	551	10	0	0	0	0	0	883
16:30	2	214	0	0	77	0	60	0	0	513	9	0	0	0	0	0	875
16:45	2	190	0	0	42	0	65	0	0	595	15	0	0	1	0	0	910
17:00	1	214	0	0	72	0	77	0	0	541	14	0	0	0	0	0	919
17:15	0	203	0	0	63	0	70	0	0	573	11	0	0	0	0	0	920
17:30	0	194	0	0	43	0	42	0	0	529	7	0	0	0	0	0	815
17:45	1	197	0	0	19	0	36	0	0	456	8	0	0	0	0	0	717
18:00																	0
18:15																	0
18:30																	0
18:45																	0
19:00																	0
19:15																	0
19:30																	0
19:45																	0
20:00																	0
20:15																	0
20:30																	0
20:45																	0
21:00																	0
21:15																	0
21:30																	0
21:45																	0
22:00																	0
22:15																	0
22:30																	0
22:45																	0
23:00																	0
23:15																	0
23:30																	0
23:45																	0
Total	771	6850	0	2	632	0	624	1	1	7813	524	0	0	1	2	0	17221
AM Peak Hr:																	7:15
Pk Vol	372	1894	0	0	85	0	25	0	0	864	164	0	0	0	0	0	3404
PHF	0.750	0.928	n/a	n/a	0.733	n/a	0.893	n/a	n/a	0.834	0.854	n/a	n/a	n/a	n/a	n/a	0.946
MID Peak Hr:																	11:15
Pk Vol	46	862	0	1	50	0	59	1	0	1057	54	0	0	1	0	0	2131
PHF	0.767	0.890	n/a	0.250	0.658	n/a	0.776	0.250	n/a	0.908	0.711	n/a	n/a	n/a	0.250	n/a	0.931
PM Peak Hr:																	16:30
Pk Vol	826	2494	526	55	2271	1075	1	0	0	2222	49	0	0	1	0	0	3624
PHF	0.625	0.959	n/a	n/a	0.825	n/a	0.883	n/a	n/a	0.934	0.817	n/a	n/a	0.250	n/a	n/a	0.985



Intersection ID: 1805409
Count Date: 11/27/2018

N 7TH AVE & W EARLL DR

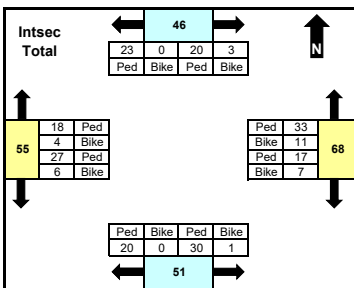
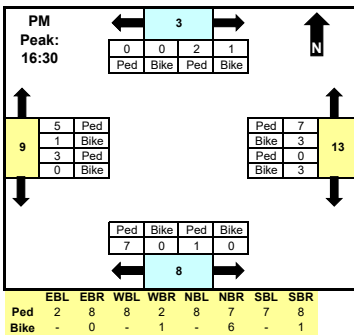
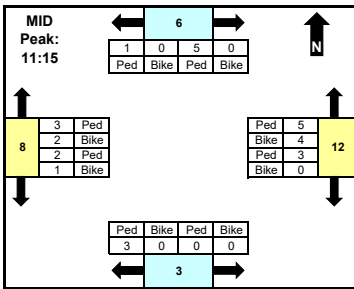
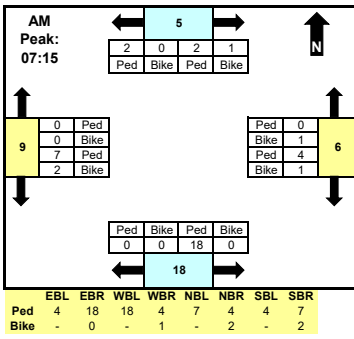

	North		East		South		West		Total
	CW	CCW	CW	CCW	CW	CCW	CW	CCW	
AM	3	2	5	1	0	18	0	9	38
MID	5	1	3	9	3	0	5	3	29
PM	3	0	3	10	7	1	6	3	33
Total	23	23	24	44	20	31	22	33	220

CW = Clockwise
CCW = Counter-clockwise

Comments

Unless shown otherwise, MID period defined as 10:00 AM - 2:00 PM. Crosswalk peaks defined based on total intersection volume for all vehicle types.

Time	North Leg		East Leg		South Leg		West Leg		INTSEC	TOTAL							
	CW	CCW	CW	CCW	CW	CCW	CW	CCW									
0:00										0							
0:15										0							
0:30										0							
0:45										0							
1:00										0							
1:15										0							
1:30										0							
1:45										0							
2:00										0							
2:15										0							
2:30										0							
2:45										0							
3:00										0							
3:15										0							
3:30										0							
3:45										0							
4:00										0							
4:15										0							
4:30										0							
4:45										0							
5:00										0							
5:15										0							
5:30										0							
5:45										0							
6:00										0							
6:15										0							
6:30	1	0	0	0	0	0	0	4	0	1	0	2	0	8			
6:45	0	0	0	0	0	0	1	0	0	2	0	0	0	1	0	4	
7:00	5	0	0	0	6	0	0	0	3	0	0	0	0	1	0	15	
7:15	1	0	0	0	2	0	0	0	8	0	0	0	0	3	1	15	
7:30	1	0	0	0	2	1	0	1	0	2	0	0	0	2	0	9	
7:45	0	1	2	0	0	0	0	0	2	0	0	0	0	0	1	6	
8:00	0	0	0	0	0	0	0	0	6	0	0	0	0	2	0	8	
8:15	0	0	0	0	0	0	0	0	0	0	0	0	0	1	0	3	
8:30																0	
8:45																0	
9:00																0	
9:15																0	
9:30																0	
9:45																0	
10:00																0	
10:15																0	
10:30																0	
10:45																0	
11:00	0	0	0	0	2	0	0	0	2	0	0	1	0	0	1	3	
11:15	1	0	0	0	1	0	0	0	1	0	0	0	1	0	1	6	
11:30	1	0	1	0	0	0	3	3	2	0	0	0	1	1	0	12	
11:45	1	0	0	0	0	0	2	1	0	0	0	0	1	0	0	5	
12:00	2	0	0	0	2	0	0	0	0	0	0	0	1	1	0	6	
12:15	0	0	1	0	1	1	4	1	0	0	0	0	0	2	0	10	
12:30	1	0	1	0	0	1	0	0	2	0	0	0	0	0	0	5	
12:45	0	0	0	0	0	0	0	0	0	0	0	0	0	0	0	0	
13:00																0	
13:15																0	
13:30																0	
13:45																0	
14:00																0	
14:15																0	
14:30																0	
14:45																0	
15:00																0	
15:15																0	
15:30																0	
15:45																0	
16:00	1	0	12	0	0	0	12	0	3	0	0	0	3	0	2	33	
16:15	1	0	2	0	0	0	1	2	3	0	0	0	4	0	3	16	
16:30	1	0	0	0	0	0	3	2	3	0	1	0	2	0	1	13	
16:45	0	1	0	0	0	2	3	0	1	0	0	0	1	0	0	8	
17:00	0	0	0	0	0	1	0	0	2	0	0	0	0	1	2	6	
17:15	1	0	0	0	0	0	1	1	1	0	0	0	2	0	0	6	
17:30	0	0	1	0	1	1	2	0	0	0	0	0	1	1	0	7	
17:45	2	1	3	0	0	0	1	0	0	0	0	2	0	1	0	10	
18:00																0	
18:15																0	
18:30																0	
18:45																0	
19:00																0	
19:15																0	
19:30																0	
19:45																0	
20:00																0	
20:15																0	
20:30																0	
20:45																0	
21:00																0	
21:15																0	
21:30																0	
21:45																0	
22:00																0	
22:15																0	
22:30																0	
22:45																0	
23:00																0	
23:15																0	
23:30																0	
23:45																0	
Total	20	3	23	0	17	7	33	11	20	0	30	1	18	4	27	6	220
AM Peak Hr:																	7:15
PK Vol	2	1	2	0	4	1	0	1	0	0	18	0	0	0	7	2	38
MID Peak Hr:																	11:15
PK Vol	5	0	1	0	3	0	5	4	3	0	0	0	3	2	2	1	29
PM Peak Hr:																	16:30
PK Vol	2	1	0	0	0	3	7	3	7	0	1	0	5	1	3	0	33

Intersection ID: 1805409
Count Date: 11/27/2018

N 7TH AVE & W EARLL DR

From North (SB) From East (WB) From South (NB) From West (EB)
N 7TH AVE W EARLL DR N 7TH AVE W EARLL DR INTSEC

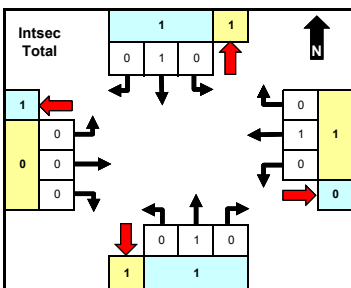
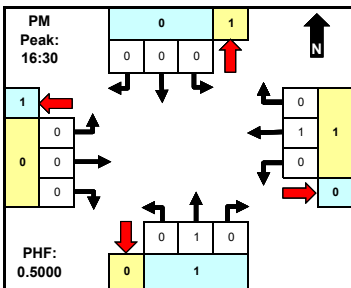
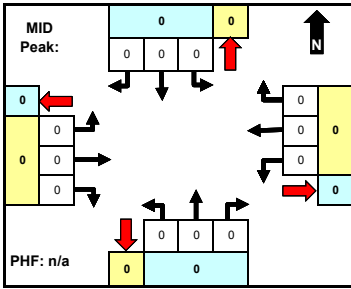
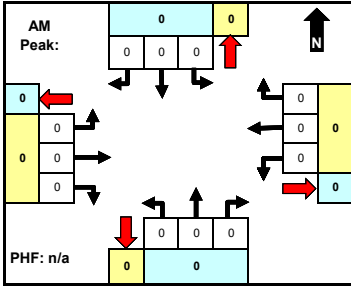

	North		East		South		West		Total
	App	Dep	App	Dep	App	Dep	App	Dep	
AM	0	0	0	0	0	0	0	0	0
MID	0	0	0	0	0	0	0	0	0
PM	0	1	1	0	1	0	0	1	2
Total	1	1	1	0	1	1	0	1	3

Comments

Unless shown otherwise, MID period defined as 10:00 AM - 2:00 PM. Peaks defined based on total intersection volume for all vehicle types.

Time	From North (SB)				From East (WB)				From South (NB)				From West (EB)				INTSEC
	LT	Thru	RT	U	LT	Thru	RT	U	LT	Thru	RT	U	LT	Thru	RT	U	
0:00																	0
0:15																	0
0:30																	0
0:45																	0
1:00																	0
1:15																	0
1:30																	0
1:45																	0
2:00																	0
2:15																	0
2:30																	0
2:45																	0
3:00																	0
3:15																	0
3:30																	0
3:45																	0
4:00																	0
4:15																	0
4:30																	0
4:45																	0
5:00																	0
5:15																	0
5:30																	0
5:45																	0
6:00																	0
6:15																	0
6:30	0	0	0	0	0	0	0	0	0	0	0	0	0	0	0	0	
6:45	0	0	0	0	0	0	0	0	0	0	0	0	0	0	0	0	
7:00	0	0	0	0	0	0	0	0	0	0	0	0	0	0	0	0	
7:15	0	0	0	0	0	0	0	0	0	0	0	0	0	0	0	0	
7:30	0	0	0	0	0	0	0	0	0	0	0	0	0	0	0	0	
7:45	0	0	0	0	0	0	0	0	0	0	0	0	0	0	0	0	
8:00	0	0	0	0	0	0	0	0	0	0	0	0	0	0	0	0	
8:15	0	0	0	0	0	0	0	0	0	0	0	0	0	0	0	0	
8:30																	0
8:45																	0
9:00																	0
9:15																	0
9:30																	0
9:45																	0
10:00																	0
10:15																	0
10:30																	0
10:45																	0
11:00	0	0	0	0	0	0	0	0	0	0	0	0	0	0	0	0	
11:15	0	0	0	0	0	0	0	0	0	0	0	0	0	0	0	0	
11:30	0	0	0	0	0	0	0	0	0	0	0	0	0	0	0	0	
11:45	0	0	0	0	0	0	0	0	0	0	0	0	0	0	0	0	
12:00	0	0	0	0	0	0	0	0	0	0	0	0	0	0	0	0	
12:15	0	0	0	0	0	0	0	0	0	0	0	0	0	0	0	0	
12:30	0	0	0	0	0	0	0	0	0	0	0	0	0	0	0	0	
12:45	0	0	0	0	0	0	0	0	0	0	0	0	0	0	0	0	
13:00																	0
13:15																	0
13:30																	0
13:45																	0
14:00																	0
14:15																	0
14:30																	0
14:45																	0
15:00																	0
15:15																	0
15:30																	0
15:45																	0
16:00	0	1	0	0	0	0	0	0	0	0	0	0	0	0	0	1	
16:15	0	0	0	0	0	0	0	0	0	0	0	0	0	0	0	0	
16:30	0	0	0	0	0	1	0	0	0	0	0	0	0	0	0	1	
16:45	0	0	0	0	0	0	0	0	0	0	0	0	0	0	0	0	
17:00	0	0	0	0	0	0	0	0	0	0	0	0	0	0	0	0	
17:15	0	0	0	0	0	0	0	0	0	1	0	0	0	0	0	1	
17:30	0	0	0	0	0	0	0	0	0	0	0	0	0	0	0	0	
17:45	0	0	0	0	0	0	0	0	0	0	0	0	0	0	0	0	
18:00																	0
18:15																	0
18:30																	0
18:45																	0
19:00																	0
19:15																	0
19:30																	0
19:45																	0
20:00																	0
20:15																	0
20:30																	0
20:45																	0
21:00																	0
21:15																	0
21:30																	0
21:45																	0
22:00																	0
22:15																	0
22:30																	0
22:45																	0
23:00																	0
23:15																	0
23:30																	0
23:45																	0
Total	0	1	0	0	0	0	1	0	0	0	1	0	0	0	0	0	3
AM Peak Hr:	7:15																
Pk Vol	0	0	0	0	0	0	0	0	0	0	0	0	0	0	0	0	0
PHF	n/a	n/a	n/a	n/a	n/a	n/a	n/a	n/a	n/a	n/a	n/a	n/a	n/a	n/a	n/a	n/a	n/a
MID Peak Hr:	11:15																
Pk Vol	0	0	0	0	0	0	0	0	0	0	0	0	0	0	0	0	0
PHF	n/a	n/a	n/a	n/a	n/a	n/a	n/a	n/a	n/a	n/a	n/a	n/a	n/a	n/a	n/a	n/a	n/a
PM Peak Hr:	16:30																
Pk Vol	0	0	0	0	0	1	0	0	0	1	0	0	0	0	0	0	2
PHF	n/a	n/a	n/a	n/a	n/a	0.250	n/a	n/a	n/a	0.250	n/a	n/a	n/a	n/a	n/a	n/a	0.500

Intersection ID: 1805120
Count Date: 11/27/2018

N 7TH AVE & W OSBORN RD

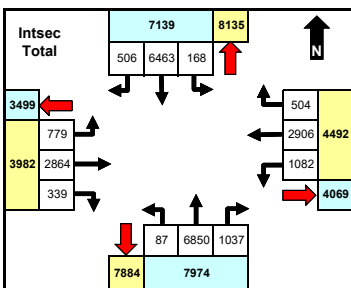
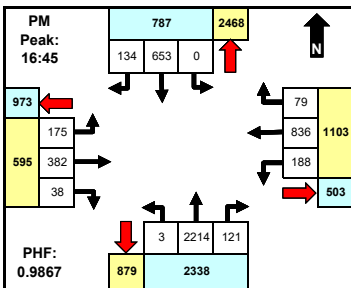
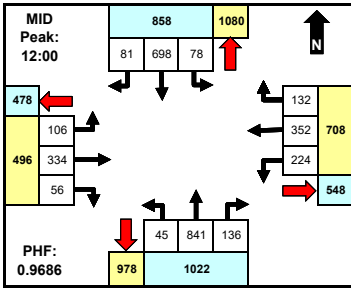
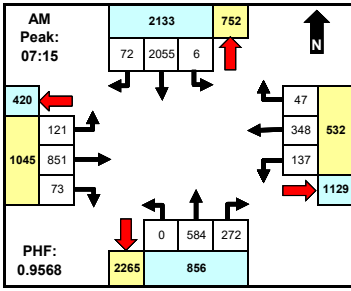

	North		East		South		West		Total
	App	Dep	App	Dep	App	Dep	App	Dep	
AM	2133	752	532	1129	856	2265	1045	420	4566
MID	858	1080	708	548	1022	978	496	478	3084
PM	787	2468	1103	503	2338	879	595	973	4823
Total	7139	8135	4492	4069	7974	7884	3982	3499	###

Comments

Unless shown otherwise, MID period defined as 10:00 AM - 2:00 PM. Peaks defined based on total intersection volume for all vehicle types.

Time	From North (SB)				From East (WB)				From South (NB)				From West (EB)				INTSEC	TOTAL
	N 7TH AVE	W OSBORN RD	N 7TH AVE	W OSBORN RD	N 7TH AVE	W OSBORN RD	N 7TH AVE	W OSBORN RD	N 7TH AVE	W OSBORN RD	N 7TH AVE	W OSBORN RD	N 7TH AVE	W OSBORN RD				
0:00																	0	
0:15																	0	
0:30																	0	
0:45																	0	
1:00																	0	
1:15																	0	
1:30																	0	
1:45																	0	
2:00																	0	
2:15																	0	
2:30																	0	
2:45																	0	
3:00																	0	
3:15																	0	
3:30																	0	
3:45																	0	
4:00																	0	
4:15																	0	
4:30																	0	
4:45																	0	
5:00																	0	
5:15																	0	
5:30																	0	
5:45																	0	
6:00																	0	
6:15																	0	
6:30	1	339	13	0	23	39	3	0	0	64	34	0	11	124	20	0	671	
6:45	1	475	13	0	20	38	4	0	0	113	46	0	15	159	21	0	905	
7:00	0	473	18	0	34	59	9	0	0	118	52	0	23	171	25	0	982	
7:15	2	517	20	0	41	84	7	0	0	126	54	0	32	202	24	0	1109	
7:30	1	514	24	0	41	93	12	0	0	155	65	0	24	220	12	0	1161	
7:45	1	515	14	0	18	84	12	0	0	171	86	0	34	236	22	0	1193	
8:00	2	509	14	0	37	87	16	0	0	132	67	0	31	193	15	0	1103	
8:15	2	485	17	0	41	83	11	0	0	127	68	0	27	215	17	0	1093	
8:30																	0	
8:45																	0	
9:00																	0	
9:15																	0	
9:30																	0	
9:45																	0	
10:00																	0	
10:15																	0	
10:30																	0	
10:45																	0	
11:00	20	163	15	0	45	90	44	0	0	178	43	0	16	60	13	0	687	
11:15	14	165	13	0	50	67	19	0	7	226	43	0	44	73	15	0	736	
11:30	19	143	11	0	50	78	39	0	8	185	42	0	40	60	17	0	692	
11:45	25	155	16	0	55	83	36	0	12	223	41	0	30	84	12	0	772	
12:00	24	179	15	1	56	85	37	0	12	225	28	0	25	67	13	0	767	
12:15	20	164	18	0	60	91	32	0	9	200	34	0	20	79	12	0	739	
12:30	14	182	31	0	55	85	35	0	8	212	32	0	24	90	14	0	782	
12:45	20	173	17	0	53	91	28	0	16	204	42	0	37	98	17	0	796	
13:00																	0	
13:15																	0	
13:30																	0	
13:45																	0	
14:00																	0	
14:15																	0	
14:30																	0	
14:45																	0	
15:00																	0	
15:15																	0	
15:30																	0	
15:45																	0	
16:00	0	185	25	0	58	201	20	0	4	498	39	0	33	90	11	0	1164	
16:15	0	165	25	0	53	195	19	0	1	547	41	0	46	84	6	0	1182	
16:30	0	164	24	0	43	235	14	0	2	492	33	0	48	98	8	0	1161	
16:45	0	170	31	0	40	198	24	0	1	565	37	0	44	105	7	0	1222	
17:00	0	167	36	0	55	194	18	0	1	570	25	0	50	86	8	0	1210	
17:15	0	161	39	0	43	242	19	0	1	528	27	0	46	102	8	0	1216	
17:30	0	155	28	0	50	202	18	0	0	551	32	0	35	89	15	0	1175	
17:45	2	145	29	1	61	202	28	0	5	440	26	0	44	79	7	0	1069	
18:00																	0	
18:15																	0	
18:30																	0	
18:45																	0	
19:00																	0	
19:15																	0	
19:30																	0	
19:45																	0	
20:00																	0	
20:15																	0	
20:30																	0	
20:45																	0	
21:00																	0	
21:15																	0	
21:30																	0	
21:45																	0	
22:00																	0	
22:15																	0	
22:30																	0	
22:45																	0	
23:00																	0	
23:15																	0	
23:30																	0	
23:45																	0	
Total	168	6463	506	2	1082	2906	504	0	87	6850	1037	0	779	2864	339	0	23587	
AM Peak Hr:																	7:15	
Pk Vol	6	2055	72	0	137	348	47	0	0	584	272	0	121	851	73	0	4566	
PHF	0.750	0.994	0.750	n/a	0.835	0.935	0.734	n/a	n/a	0.854	0.791	n/a	0.890	0.901	0.760	n/a	0.957	
MID Peak Hr:																	12:00	
Pk Vol	78	698	81	1	224	352	132	0	45	841	136	0	106	334	56	0	3084	
PHF	0.613	0.959	0.653	0.250	0.933	0.967	0.892	n/a	0.703	0.934	0.810	n/a	0.716	0.852	0.824	n/a	0.969	
PM Peak Hr:																	16:45	
Pk Vol	0	663	134	0	188	836	79	0	3	2214	121	0	175	382	38	0	4823	
PHF	n/a	0.960	0.859	n/a	0.855	0.864	0.823	n/a	0.750									

Intersection ID: 1805120
Count Date: 11/27/2018

N 7TH AVE & W OSBORN RD

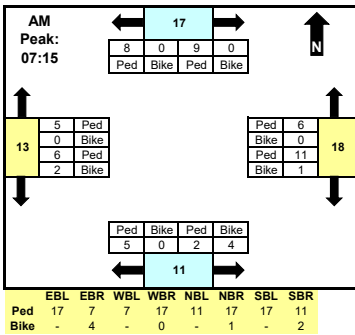

Intersection ID: 1805120
Count Date: 11/27/2018

N 7TH AVE & W OSBORN RD

From North (SB) From East (WB) From South (NB) From West (EB) INTSEC
N 7TH AVE W OSBORN RD N 7TH AVE W OSBORN RD

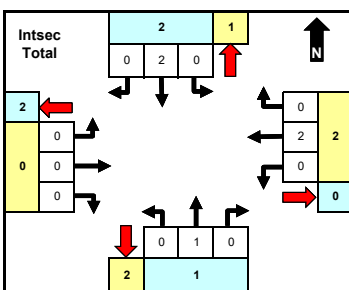
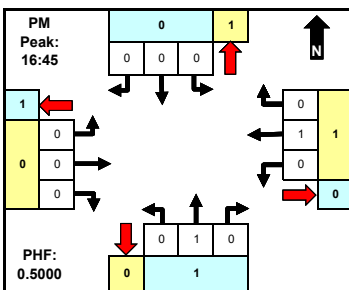
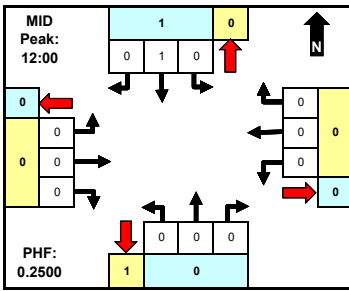
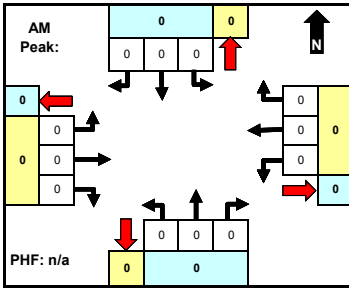

	North		East		South		West		Total
	App	Dep	App	Dep	App	Dep	App	Dep	
AM	0	0	0	0	0	0	0	0	0
MID	1	0	0	0	0	1	0	0	1
PM	0	1	1	0	1	0	0	1	2
Total	2	1	2	0	1	2	0	2	5

Comments

Unless shown otherwise, MID period defined as 10:00 AM - 2:00 PM. Peaks defined based on total intersection volume for all vehicle types.

Time	From North (SB)				From East (WB)				From South (NB)				From West (EB)				INTSEC
	LT	Thru	RT	U	LT	Thru	RT	U	LT	Thru	RT	U	LT	Thru	RT	U	
0:00																	0
0:15																	0
0:30																	0
0:45																	0
1:00																	0
1:15																	0
1:30																	0
1:45																	0
2:00																	0
2:15																	0
2:30																	0
2:45																	0
3:00																	0
3:15																	0
3:30																	0
3:45																	0
4:00																	0
4:15																	0
4:30																	0
4:45																	0
5:00																	0
5:15																	0
5:30																	0
5:45																	0
6:00																	0
6:15																	0
6:30	0	0	0	0	0	0	0	0	0	0	0	0	0	0	0	0	
6:45	0	0	0	0	0	0	0	0	0	0	0	0	0	0	0	0	
7:00	0	0	0	0	0	0	0	0	0	0	0	0	0	0	0	0	
7:15	0	0	0	0	0	0	0	0	0	0	0	0	0	0	0	0	
7:30	0	0	0	0	0	0	0	0	0	0	0	0	0	0	0	0	
7:45	0	0	0	0	0	0	0	0	0	0	0	0	0	0	0	0	
8:00	0	0	0	0	0	0	0	0	0	0	0	0	0	0	0	0	
8:15	0	0	0	0	0	0	0	0	0	0	0	0	0	0	0	0	
8:30																	0
8:45																	0
9:00																	0
9:15																	0
9:30																	0
9:45																	0
10:00																	0
10:15																	0
10:30																	0
10:45																	0
11:00	0	0	0	0	0	0	0	0	0	0	0	0	0	0	0	0	
11:15	0	0	0	0	0	0	0	0	0	0	0	0	0	0	0	0	
11:30	0	0	0	0	0	0	0	0	0	0	0	0	0	0	0	0	
11:45	0	0	0	0	0	0	0	0	0	0	0	0	0	0	0	0	
12:00	0	0	0	0	0	0	0	0	0	0	0	0	0	0	0	0	
12:15	0	1	0	0	0	0	0	0	0	0	0	0	0	0	0	1	
12:30	0	0	0	0	0	0	0	0	0	0	0	0	0	0	0	0	
12:45	0	0	0	0	0	0	0	0	0	0	0	0	0	0	0	0	
13:00																	0
13:15																	0
13:30																	0
13:45																	0
14:00																	0
14:15																	0
14:30																	0
14:45																	0
15:00																	0
15:15																	0
15:30																	0
15:45																	1
16:00	0	1	0	0	0	0	0	0	0	0	0	0	0	0	0	1	
16:15	0	0	0	0	0	1	0	0	0	0	0	0	0	0	0	1	
16:30	0	0	0	0	0	0	0	0	0	0	0	0	0	0	0	0	
16:45	0	0	0	0	0	0	0	0	0	0	0	0	0	0	0	0	
17:00	0	0	0	0	0	0	0	0	0	0	0	0	0	0	0	0	
17:15	0	0	0	0	0	1	0	0	0	0	0	0	0	0	0	1	
17:30	0	0	0	0	0	0	0	0	0	1	0	0	0	0	0	1	
17:45	0	0	0	0	0	0	0	0	0	0	0	0	0	0	0	0	
18:00																	0
18:15																	0
18:30																	0
18:45																	0
19:00																	0
19:15																	0
19:30																	0
19:45																	0
20:00																	0
20:15																	0
20:30																	0
20:45																	0
21:00																	0
21:15																	0
21:30																	0
21:45																	0
22:00																	0
22:15																	0
22:30																	0
22:45																	0
23:00																	0
23:15																	0
23:30																	0
23:45																	0
Total	0	2	0	0	0	2	0	0	0	1	0	0	0	0	0	5	
AM Peak Hr:																	7:15
Pk Vol	0	0	0	0	0	0	0	0	0	0	0	0	0	0	0	0	
PHF	n/a	n/a	n/a	n/a	n/a	n/a	n/a	n/a	n/a	n/a	n/a	n/a	n/a	n/a	n/a	n/a	
MID Peak Hr:																	12:00
Pk Vol	0	1	0	0	0	0	0	0	0	0	0	0	0	0	0	1	
PHF	n/a	0.250	n/a	n/a	n/a	n/a	n/a	n/a	n/a	n/a	n/a	n/a	n/a	n/a	n/a	0.250	
PM Peak Hr:																	16:45
Pk Vol	0	0	0	0	0	1	0	0	0	1	0	0	0	0	0	2	
PHF	n/a	n/a	n/a	n/a	n/a	0.250	n/a	n/a	n/a	0.250	n/a	n/a	n/a	n/a	n/a	0.500	

Intersection ID: 1805119
Count Date: 11/27/2018

N 7TH AVE & W INDIAN SCHOOL RD

From North (SB) From East (WB) From South (NB) From West (EB)
N 7TH AVE W INDIAN SCHOOL RD N 7TH AVE W INDIAN SCHOOL RD INTSEC

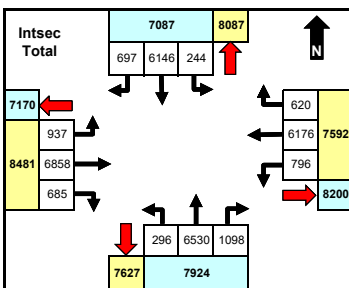
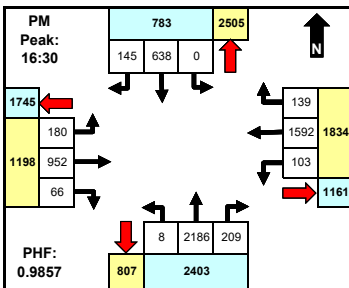
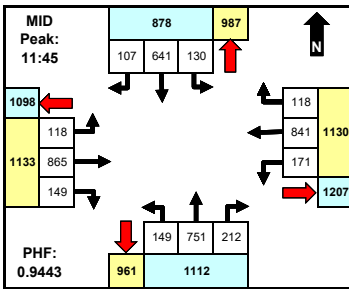
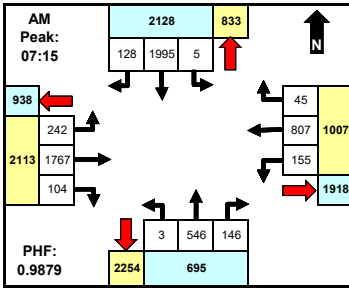

	North		East		South		West		Total
	App	Dep	App	Dep	App	Dep	App	Dep	
AM	2128	833	1007	1918	695	2254	2113	938	5943
MID	878	987	1130	1207	1112	961	1133	1098	4253
PM	783	2505	1834	1161	2403	807	1198	1745	6218
Total	7087	8087	7592	8200	7924	7627	8481	7170	###

Time	LT	Thru	RT	U	LT	Thru	RT	U	LT	Thru	RT	U	LT	Thru	RT	U	TOTAL
0:00																	0
0:15																	0
0:30																	0
0:45																	0
1:00																	0
1:15																	0
1:30																	0
1:45																	0
2:00																	0
2:15																	0
2:30																	0
2:45																	0
3:00																	0
3:15																	0
3:30																	0
3:45																	0
4:00																	0
4:15																	0
4:30																	0
4:45																	0
5:00																	0
5:15																	0
5:30																	0
5:45																	0
6:00																	0
6:15																	0
6:30	2	359	16	0	20	115	4	0	0	56	20	0	18	383	32	0	1025
6:45	2	364	19	0	30	136	10	0	0	85	25	0	41	436	47	0	1195
7:00	1	507	20	0	34	123	12	0	0	121	36	0	42	408	43	0	1347
7:15	0	490	21	0	29	218	10	0	0	119	35	0	66	489	27	0	1504
7:30	3	518	40	0	39	194	8	0	1	151	33	0	65	421	28	0	1501
7:45	0	459	33	0	45	211	7	0	1	152	38	0	76	456	25	0	1503
8:00	2	528	34	0	42	184	20	0	1	124	40	0	35	401	24	0	1435
8:15	5	433	26	0	37	178	9	0	0	115	39	0	32	352	33	0	1259
8:30																	0
8:45																	0
9:00																	0
9:15																	0
9:30																	0
9:45																	0
10:00																	0
10:15																	0
10:30																	0
10:45																	0
11:00	27	138	13	0	34	197	33	0	25	154	50	0	16	186	37	0	910
11:15	19	139	15	0	34	210	35	0	30	208	53	0	30	216	35	0	1024
11:30	22	140	19	0	35	228	34	0	31	187	45	0	29	201	27	0	998
11:45	28	137	25	0	36	198	28	0	43	192	44	0	31	244	42	0	1048
12:00	34	178	23	0	40	230	31	0	40	171	63	0	30	184	37	1	1062
12:15	31	149	29	0	45	194	35	0	36	174	45	0	26	225	28	0	1017
12:30	37	177	30	0	50	219	24	0	30	214	60	0	31	212	42	0	1126
12:45	25	162	21	0	32	209	27	0	26	170	75	0	31	188	34	0	1000
13:00																	0
13:15																	0
13:30																	0
13:45																	0
14:00																	0
14:15																	0
14:30																	0
14:45																	0
15:00																	0
15:15																	0
15:30																	0
15:45																	0
16:00	1	183	41	0	22	348	33	0	8	487	46	0	32	228	22	0	1451
16:15	1	143	52	0	22	436	41	0	1	496	43	0	40	244	25	0	1544
16:30	0	170	43	0	18	387	25	0	0	560	56	0	46	220	16	0	1541
16:45	0	141	24	0	21	422	32	0	3	540	47	0	51	252	21	0	1554
17:00	0	175	43	0	30	384	31	0	5	553	62	0	37	212	14	0	1546
17:15	0	152	35	0	34	399	51	0	0	533	44	0	46	268	15	0	1577
17:30	1	173	40	0	30	365	45	0	5	545	48	0	40	223	16	0	1531
17:45	3	131	35	0	37	391	35	0	10	423	51	0	46	209	15	0	1366
18:00																	0
18:15																	0
18:30																	0
18:45																	0
19:00																	0
19:15																	0
19:30																	0
19:45																	0
20:00																	0
20:15																	0
20:30																	0
20:45																	0
21:00																	0
21:15																	0
21:30																	0
21:45																	0
22:00																	0
22:15																	0
22:30																	0
22:45																	0
23:00																	0
23:15																	0
23:30																	0
23:45																	0
Total	244	6146	697	0	796	6176	620	0	296	6530	1098	0	937	6858	685	1	31084

Comments

Unless shown otherwise, MID period defined as 10:00 AM - 2:00 PM. Peaks defined based on total intersection volume for all vehicle types.

AM Peak Hr:	7:15																
Pk Vol	5	1995	128	0	155	807	45	0	3	546	146	0	242	1767	104	0	5943
PHF	0.417	0.945	0.800	n/a	0.861	0.925	0.563	n/a	0.750	0.898	0.913	n/a	0.796	0.903	0.929	n/a	0.988
MID Peak Hr:	11:45																
Pk Vol	130	641	107	0	171	841	118	0	149	751	212	0	118	865	149	1	4253
PHF	0.878	0.900	0.892	n/a	0.855	0.914	0.843	n/a	0.866	0.877	0.841	n/a	0.952	0.886	0.887	0.250	0.844
PM Peak Hr:	16:30																
Pk Vol	0	638	145	0	103	1592	139	0	8	2186	209	0	180	952	66	0	6218
PHF	n/a	0.911	0.843	n/a	0.757	0.943	0.681	n/a									

Intersection ID: 1805119
Count Date: 11/27/2018

N 7TH AVE & W INDIAN SCHOOL RD

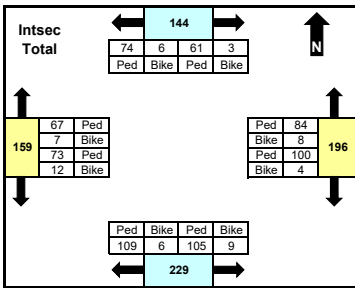
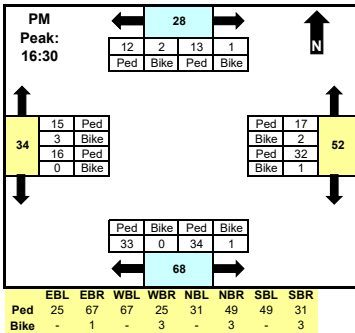
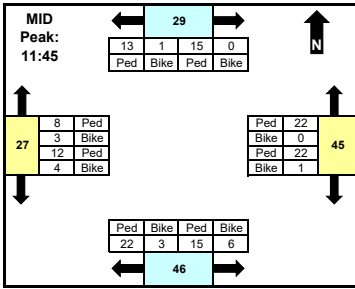
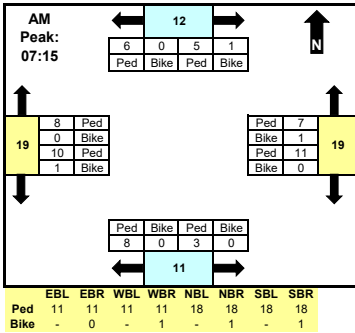

	North		East		South		West		Total
	CW	CCW	CW	CCW	CW	CCW	CW	CCW	
AM	6	6	11	8	8	3	8	11	61
MID	15	14	23	22	25	21	11	16	147
PM	14	14	33	19	33	35	18	16	182
Total	64	80	104	92	115	114	74	85	728

CW = Clockwise
CCW = Counter-clockwise

Comments

Unless shown otherwise, MID period defined as 10:00 AM - 2:00 PM. Crosswalk peaks defined based on total intersection volume for all vehicle types.

Time	North Leg		East Leg		South Leg		West Leg		INTSEC	TOTAL								
	CW	CCW	CW	CCW	CW	CCW	CW	CCW										
0:00										0								
0:15										0								
0:30										0								
0:45										0								
1:00										0								
1:15										0								
1:30										0								
1:45										0								
2:00										0								
2:15										0								
2:30										0								
2:45										0								
3:00										0								
3:15										0								
3:30										0								
3:45										0								
4:00										0								
4:15										0								
4:30										0								
4:45										0								
5:00										0								
5:15										0								
5:30										0								
5:45										0								
6:00										0								
6:15										0								
6:30	3	1	0	0	0	0	3	0	2	0	0	0	0	0	0	11		
6:45	2	0	7	0	1	0	0	0	1	0	2	0	0	0	0	1	0	14
7:00	1	0	1	0	4	0	3	0	0	1	0	2	0	3	0	6	1	22
7:15	1	1	2	0	1	0	1	0	2	0	1	0	3	0	2	0	2	14
7:30	3	0	0	0	3	0	0	0	0	0	0	0	2	0	1	0	9	
7:45	0	0	3	0	0	0	2	1	2	0	2	0	2	0	6	1	18	
8:00	1	0	1	0	7	0	4	0	4	0	0	0	1	0	1	0	18	
8:15	4	0	3	0	8	0	3	2	4	0	0	0	4	0	2	1	31	
8:30																	0	0
8:45																	0	0
9:00																	0	0
9:15																	0	0
9:30																	0	0
9:45																	0	0
10:00																	0	0
10:15																	0	0
10:30																	0	0
10:45																	0	0
11:00	0	0	1	1	1	0	4	0	5	0	3	0	1	0	1	0	17	
11:15	1	0	7	1	1	0	2	1	5	1	4	0	2	0	4	1	30	
11:30	5	0	8	0	0	0	6	0	2	0	6	0	4	1	4	0	36	
11:45	7	0	4	0	5	0	4	0	7	1	7	1	3	1	2	0	42	
12:00	1	0	2	0	5	0	7	0	4	1	4	2	1	2	1	4	34	
12:15	4	0	3	1	7	1	6	0	7	1	0	2	3	0	6	0	41	
12:30	3	0	4	0	5	0	5	0	4	0	4	1	1	0	3	0	30	
12:45	3	0	4	1	6	0	6	0	4	0	12	1	2	0	4	0	43	
13:00																	0	0
13:15																	0	0
13:30																	0	0
13:45																	0	0
14:00																	0	0
14:15																	0	0
14:30																	0	0
14:45																	0	0
15:00																	0	0
15:15																	0	0
15:30																	0	0
15:45																	0	0
16:00	3	0	2	0	5	0	2	0	3	1	4	0	6	0	7	2	35	
16:15	4	0	7	0	4	0	2	1	9	0	11	0	6	0	4	1	49	
16:30	5	0	1	2	12	1	6	1	6	0	5	1	3	0	5	0	48	
16:45	3	0	2	0	2	0	3	0	4	0	10	0	3	2	0	0	29	
17:00	3	0	5	0	10	0	4	0	16	0	7	0	7	0	5	0	57	
17:15	2	1	4	0	8	0	4	1	7	0	12	0	2	1	6	0	48	
17:30	0	0	0	0	2	0	3	1	5	0	6	0	3	0	0	1	21	
17:45	2	0	3	0	3	2	4	0	5	1	3	1	3	0	2	0	29	
18:00																	0	0
18:15																	0	0
18:30																	0	0
18:45																	0	0
19:00																	0	0
19:15																	0	0
19:30																	0	0
19:45																	0	0
20:00																	0	0
20:15																	0	0
20:30																	0	0
20:45																	0	0
21:00																	0	0
21:15																	0	0
21:30																	0	0
21:45																	0	0
22:00																	0	0
22:15																	0	0
22:30																	0	0
22:45																	0	0
23:00																	0	0
23:15																	0	0
23:30																	0	0
23:45																	0	0
Total	61	3	74	6	100	4	84	8	109	6	105	9	67	7	73	12	728	
AM Peak Hr:																	7:15	
PK Vol	5	1	6	0	11	0	7	1										

Intersection ID: 1805119
Count Date: 11/27/2018

N 7TH AVE & W INDIAN SCHOOL RD

From North (SB) From East (WB) From South (NB) From West (EB)
N 7TH AVE W INDIAN SCHOOL RD N 7TH AVE W INDIAN SCHOOL RD INTSEC

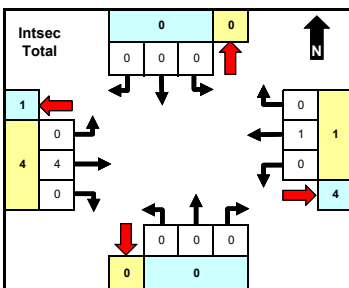
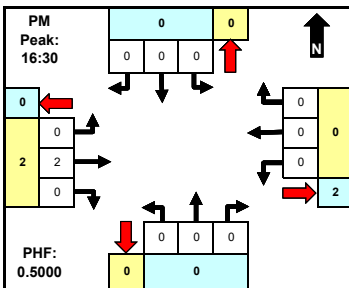
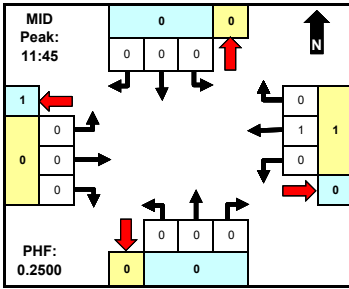
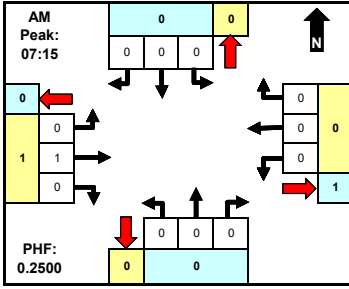

	North		East		South		West		Total
	App	Dep	App	Dep	App	Dep	App	Dep	
AM	0	0	0	1	0	0	1	0	1
MID	0	0	1	0	0	0	0	1	1
PM	0	0	0	2	0	0	2	0	2
Total	0	0	1	4	0	0	4	1	5

Comments

Unless shown otherwise, MID period defined as 10:00 AM - 2:00 PM. Peaks defined based on total intersection volume for all vehicle types.

Time	LT	Thru	RT	U	LT	Thru	RT	U	LT	Thru	RT	U	LT	Thru	RT	U	TOTAL
0:00																	0
0:15																	0
0:30																	0
0:45																	0
1:00																	0
1:15																	0
1:30																	0
1:45																	0
2:00																	0
2:15																	0
2:30																	0
2:45																	0
3:00																	0
3:15																	0
3:30																	0
3:45																	0
4:00																	0
4:15																	0
4:30																	0
4:45																	0
5:00																	0
5:15																	0
5:30																	0
5:45																	0
6:00																	0
6:15																	0
6:30	0	0	0	0	0	0	0	0	0	0	0	0	0	0	0	0	0
6:45	0	0	0	0	0	0	0	0	0	0	0	0	0	0	0	0	0
7:00	0	0	0	0	0	0	0	0	0	0	0	0	0	0	0	0	0
7:15	0	0	0	0	0	0	0	0	0	0	0	0	0	0	0	0	0
7:30	0	0	0	0	0	0	0	0	0	0	0	0	0	0	0	0	0
7:45	0	0	0	0	0	0	0	0	0	0	0	0	0	0	0	0	0
8:00	0	0	0	0	0	0	0	0	0	0	0	0	0	0	0	0	0
8:15	0	0	0	0	0	0	0	0	0	0	0	0	0	0	0	0	0
8:30																	0
8:45																	0
9:00																	0
9:15																	0
9:30																	0
9:45																	0
10:00																	0
10:15																	0
10:30																	0
10:45																	0
11:00	0	0	0	0	0	0	0	0	0	0	0	0	0	0	0	0	0
11:15	0	0	0	0	0	0	0	0	0	0	0	0	0	0	0	0	0
11:30	0	0	0	0	0	0	0	0	0	0	0	0	0	0	0	0	0
11:45	0	0	0	0	0	0	0	0	0	0	0	0	0	0	0	0	0
12:00	0	0	0	0	0	0	0	0	0	0	0	0	0	0	0	0	0
12:15	0	0	0	0	0	0	0	0	0	0	0	0	0	0	0	0	0
12:30	0	0	0	0	0	0	1	0	0	0	0	0	0	0	0	0	1
12:45	0	0	0	0	0	0	0	0	0	0	0	0	0	0	0	0	0
13:00																	0
13:15																	0
13:30																	0
13:45																	0
14:00																	0
14:15																	0
14:30																	0
14:45																	0
15:00																	0
15:15																	0
15:30																	0
15:45																	0
16:00	0	0	0	0	0	0	0	0	0	0	0	0	0	0	0	0	0
16:15	0	0	0	0	0	0	0	0	0	0	0	0	0	0	0	0	0
16:30	0	0	0	0	0	0	0	0	0	0	0	0	0	0	0	0	0
16:45	0	0	0	0	0	0	0	0	0	0	0	0	0	0	0	0	0
17:00	0	0	0	0	0	0	0	0	0	0	0	0	0	0	0	0	0
17:15	0	0	0	0	0	0	0	0	0	0	0	0	0	0	0	0	0
17:30	0	0	0	0	0	0	0	0	0	0	0	0	0	0	0	0	0
17:45	0	0	0	0	0	0	0	0	0	0	0	0	0	0	0	0	0
18:00	0	0	0	0	0	0	0	0	0	0	0	0	0	0	0	0	0
18:15																	0
18:30																	0
18:45																	0
19:00																	0
19:15																	0
19:30																	0
19:45																	0
20:00																	0
20:15																	0
20:30																	0
20:45																	0
21:00																	0
21:15																	0
21:30																	0
21:45																	0
22:00																	0
22:15																	0
22:30																	0
22:45																	0
23:00																	0
23:15																	0
23:30																	0
23:45																	0
Total	0	0	0	0	0	0	1	0	0	0	0	0	0	0	4	0	5
AM Peak Hr:																	7:15
Pk Vol	0	0	0	0	0	0	0	0	0	0	0	0	0	0	1	0	1
PHF	n/a	n/a	n/a	n/a	n/a	n/a	n/a	n/a	n/a	n/a	n/a	n/a	n/a	n/a	0.250	n/a	0.250
MID Peak Hr:																	11:45
Pk Vol	0	0	0	0	1	0	0	0	0	0	0	0	0	0	0	0	1
PHF	n/a	n/a	n/a	n/a	0.250	n/a	n/a	n/a	n/a	n/a	n/a	n/a	n/a	n/a	n/a	n/a	0.250
PM Peak Hr:																	16:30
Pk Vol	0	0	0	0	0	0	0	0	0	0	0	0	0	0	2	0	2
PHF	n/a	n/a	n/a	n/a	n/a	n/a	n/a	n/a	n/a	n/a	n/a	n/a	n/a	n/a	0.500	n/a	0.500

Intersection ID: 1805118
Count Date: 11/27/2018

N 7TH AVE & W CAMPBELL AVE

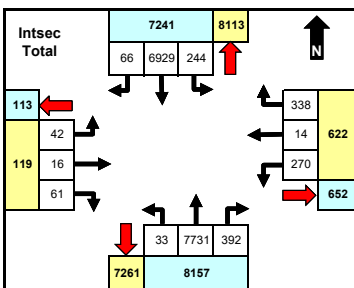
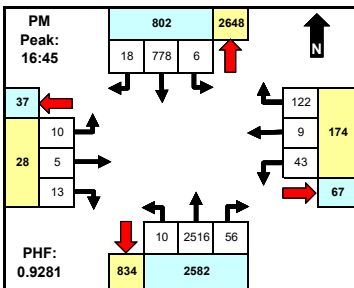
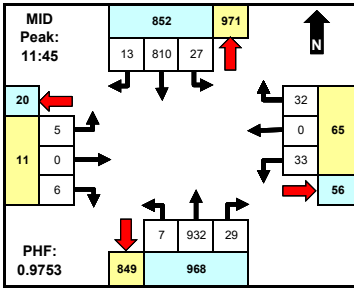
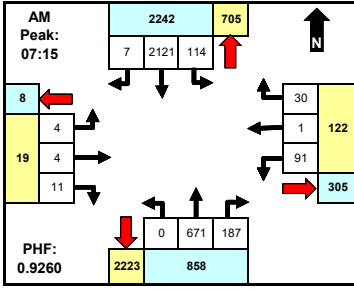

	North		East		South		West		Total
	App	Dep	App	Dep	App	Dep	App	Dep	
AM	2242	705	122	305	858	2223	19	8	3241
MID	852	971	65	56	968	849	11	20	1896
PM	802	2648	174	67	2582	834	28	37	3886
Total	7241	8113	622	652	8157	7261	119	113	16139

Comments

Unless shown otherwise, MID period defined as 10:00 AM - 2:00 PM. Peaks defined based on total intersection volume for all vehicle types.

Time	From North (SB)				From East (WB)				From South (NB)				From West (EB)				INTSEC	TOTAL
	LT	Thru	RT	U	LT	Thru	RT	U	LT	Thru	RT	U	LT	Thru	RT	U		
0:00																	0	
0:15																	0	
0:30																	0	
0:45																	0	
1:00																	0	
1:15																	0	
1:30																	0	
1:45																	0	
2:00																	0	
2:15																	0	
2:30																	0	
2:45																	0	
3:00																	0	
3:15																	0	
3:30																	0	
3:45																	0	
4:00																	0	
4:15																	0	
4:30																	0	
4:45																	0	
5:00																	0	
5:15																	0	
5:30																	0	
5:45																	0	
6:00																	0	
6:15																	0	
6:30	12	335	1	0	3	1	4	0	1	71	6	0	1	1	4	0	440	
6:45	10	406	1	0	3	1	3	0	1	117	23	0	2	0	2	0	569	
7:00	12	506	1	0	16	0	6	0	0	140	23	0	2	1	3	0	710	
7:15	20	541	0	0	13	0	2	0	0	165	50	0	0	0	1	0	792	
7:30	35	502	0	0	25	1	8	0	0	165	54	0	2	1	3	0	796	
7:45	37	550	1	0	26	0	15	0	0	180	60	0	0	1	5	0	875	
8:00	22	528	6	0	27	0	5	0	0	161	23	0	2	2	2	0	778	
8:15	36	507	3	0	10	0	8	0	1	169	6	0	1	0	2	0	743	
8:30																	0	
8:45																	0	
9:00																	0	
9:15																	0	
9:30																	0	
9:45																	0	
10:00																	0	
10:15																	0	
10:30																	0	
10:45																	0	
11:00	3	172	1	0	4	0	9	0	1	216	1	0	3	0	1	0	411	
11:15	5	152	1	0	2	0	8	0	3	234	3	1	2	1	1	0	413	
11:30	3	184	1	0	5	0	9	0	2	234	3	0	2	0	5	0	448	
11:45	6	177	3	0	10	0	11	0	0	256	7	0	0	0	2	0	472	
12:00	7	209	4	0	6	0	6	0	2	214	8	0	1	0	2	0	459	
12:15	7	218	3	1	5	0	9	0	3	225	4	0	3	0	1	0	479	
12:30	7	206	3	1	12	0	6	0	2	237	10	0	1	0	1	0	486	
12:45	10	183	0	0	7	0	7	0	2	204	11	0	3	1	3	0	431	
13:00																	0	
13:15																	0	
13:30																	0	
13:45																	0	
14:00																	0	
14:15																	0	
14:30																	0	
14:45																	0	
15:00																	0	
15:15																	0	
15:30																	0	
15:45																	0	
16:00	2	218	5	0	11	1	25	0	1	545	13	0	1	0	1	0	823	
16:15	0	178	5	0	13	0	20	0	2	598	11	0	0	1	2	0	830	
16:30	0	184	4	0	20	1	36	0	0	552	10	0	5	1	2	0	815	
16:45	0	182	3	0	7	2	29	0	3	671	15	0	2	0	2	0	916	
17:00	4	201	3	0	10	2	27	0	4	552	13	0	2	2	1	0	821	
17:15	2	199	9	0	14	4	34	0	1	683	11	0	4	2	3	0	966	
17:30	0	196	3	0	12	1	32	0	2	610	17	0	2	1	7	0	883	
17:45	4	195	5	0	9	0	19	0	2	532	10	0	1	1	5	0	763	
18:00																	0	
18:15																	0	
18:30																	0	
18:45																	0	
19:00																	0	
19:15																	0	
19:30																	0	
19:45																	0	
20:00																	0	
20:15																	0	
20:30																	0	
20:45																	0	
21:00																	0	
21:15																	0	
21:30																	0	
21:45																	0	
22:00																	0	
22:15																	0	
22:30																	0	
22:45																	0	
23:00																	0	
23:15																	0	
23:30																	0	
23:45																	0	
Total	244	6929	66	2	270	14	338	0	33	7731	392	1	42	16	61	0	16139	
AM Peak Hr:																	7:15	
PK Vol	114	2121	7	0	91	1	30	0	0	671	187	0	4	4	11	0	3241	
PHF	0.770	0.964	0.292	n/a	0.843	0.250	0.500	n/a	n/a	0.932	0.779	n/a	0.500	0.500	0.550	n/a	0.926	
MID Peak Hr:																	11:45	
PK Vol	27	816	13	2	33	0	32	0	7	932	29	0	5	0	6	0	1896	
PHF	0.964	0.929	0.813	0.500	0.688	n/a	0.727	n/a	0.583	0.910	0.725	n/a	0.417	n/a	0.750	n/a	0.975	
PM Peak Hr:																	16:45	
PK Vol	6	778	18	0	43	9	122	0	10	2616	66	0	10	5	13	0	3886	
PHF	0.375	0.968	0.500	n/a	0.768	0.563	0.897	n/a	0.625	0.921	0.824	n/a	0.625	0.625	0.464	n/a	0.928	



Intersection ID: 1805118
Count Date: 11/27/2018

N 7TH AVE & W CAMPBELL AVE

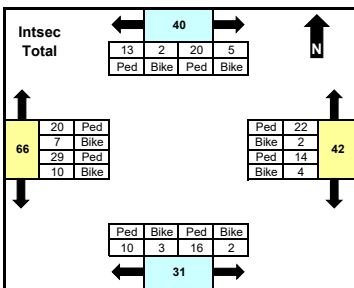
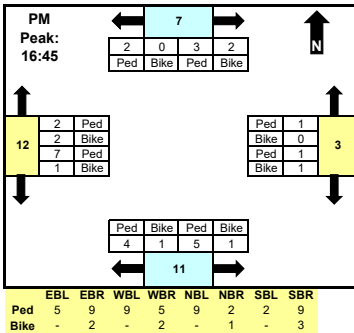
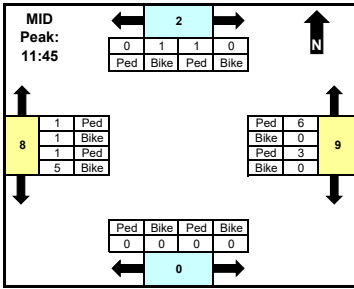
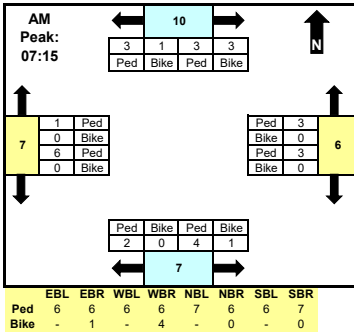

	North		East		South		West		Total
	CW	CCW	CW	CCW	CW	CCW	CW	CCW	
AM	6	4	3	3	2	5	1	6	30
MID	1	1	3	6	0	0	2	6	19
PM	5	2	2	1	5	6	4	8	33
Total	25	15	18	24	13	18	27	39	179

CW = Clockwise
CCW = Counter-clockwise

Comments

Unless shown otherwise, MID period defined as 10:00 AM - 2:00 PM. Crosswalk peaks defined based on total intersection volume for all vehicle types.

Time	North Leg		East Leg		South Leg		West Leg		INTSEC	TOTAL							
	CW	CCW	CW	CCW	CW	CCW	CW	CCW									
0:00										0							
0:15										0							
0:30										0							
0:45										0							
1:00										0							
1:15										0							
1:30										0							
1:45										0							
2:00										0							
2:15										0							
2:30										0							
2:45										0							
3:00										0							
3:15										0							
3:30										0							
3:45										0							
4:00										0							
4:15										0							
4:30										0							
4:45										0							
5:00										0							
5:15										0							
5:30										0							
5:45										0							
6:00										0							
6:15										0							
6:30	0	0	0	0	0	0	0	1	0	2							
6:45	1	0	1	0	0	0	1	0	0	3							
7:00	3	0	0	0	0	1	0	0	0	8							
7:15	0	1	0	0	0	0	1	0	0	2							
7:30	1	0	1	0	1	0	0	2	1	8							
7:45	0	1	0	1	0	0	0	1	0	7							
8:00	2	1	2	1	1	0	3	0	1	13							
8:15	0	0	0	0	1	0	1	0	0	5							
8:30										0							
8:45										0							
9:00										0							
9:15										0							
9:30										0							
9:45										0							
10:00										0							
10:15										0							
10:30										0							
10:45										0							
11:00	0	0	2	0	0	0	0	1	0	7							
11:15	0	0	0	0	0	0	0	0	2	3							
11:30	0	0	0	0	0	0	0	0	2	4							
11:45	1	0	0	0	1	0	0	0	1	5							
12:00	0	0	0	1	0	2	0	0	0	5							
12:15	0	0	0	1	0	1	0	0	0	4							
12:30	0	0	0	1	0	3	0	0	0	5							
12:45	0	0	0	2	1	1	0	0	0	8							
13:00										0							
13:15										0							
13:30										0							
13:45										0							
14:00										0							
14:15										0							
14:30										0							
14:45										0							
15:00										0							
15:15										0							
15:30										0							
15:45										0							
16:00	3	0	0	0	1	3	0	0	3	14							
16:15	4	0	0	0	2	1	0	0	3	15							
16:30	1	0	1	0	1	1	1	1	1	12							
16:45	1	0	0	1	1	0	3	0	0	11							
17:00	1	0	1	0	0	0	0	1	1	8							
17:15	1	0	1	0	0	0	0	0	2	8							
17:30	0	2	0	0	0	1	0	2	0	6							
17:45	1	0	4	0	1	5	0	2	1	16							
18:00										0							
18:15										0							
18:30										0							
18:45										0							
19:00										0							
19:15										0							
19:30										0							
19:45										0							
20:00										0							
20:15										0							
20:30										0							
20:45										0							
21:00										0							
21:15										0							
21:30										0							
21:45										0							
22:00										0							
22:15										0							
22:30										0							
22:45										0							
23:00										0							
23:15										0							
23:30										0							
23:45										0							
Total	20	5	13	2	14	4	22	2	10	3	16	2	20	7	29	10	179
AM Peak Hr:																	7:15
PK Vol	3	3	3	1	3	0	3	0	2	0	4	1	1	0	6	0	30
MID Peak Hr:																	11:45
PK Vol	1	0	0	1	3	0	6	0	0	0	0	0	1	1	1	5	19
PM Peak Hr:																	16:45
PK Vol	3	2	2	0	1	1	1	0	4	1	5	1	2	2	7	1	33

Intersection ID: 1805118
Count Date: 11/27/2018

N 7TH AVE & W CAMPBELL AVE

From North (SB) From East (WB) From South (NB) From West (EB)
N 7TH AVE W CAMPBELL AVE N 7TH AVE W CAMPBELL AVE INTSEC

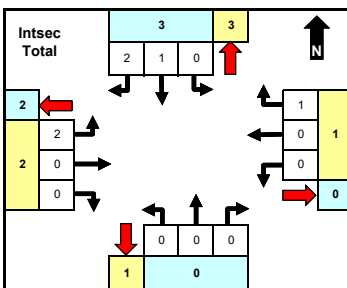
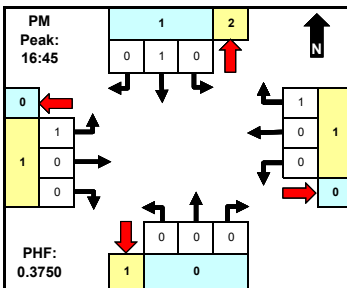
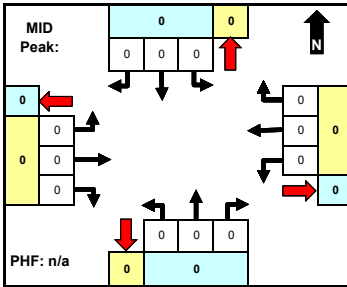
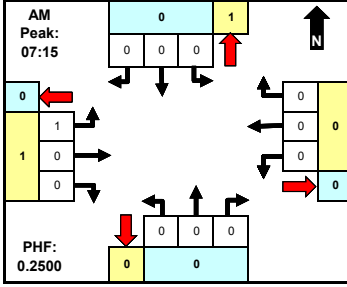

	North		East		South		West		Total
	App	Dep	App	Dep	App	Dep	App	Dep	
AM	0	1	0	0	0	0	1	0	1
MID	0	0	0	0	0	0	0	0	0
PM	1	2	1	0	0	1	1	0	3
Total	1	3	1	0	0	1	2	0	6

Comments

Unless shown otherwise, MID period defined as 10:00 AM - 2:00 PM. Peaks defined based on total intersection volume for all vehicle types.

Time	From North (SB)				From East (WB)				From South (NB)				From West (EB)				TOTAL
	LT	Thru	RT	U	LT	Thru	RT	U	LT	Thru	RT	U	LT	Thru	RT	U	
0:00																	0
0:15																	0
0:30																	0
0:45																	0
1:00																	0
1:15																	0
1:30																	0
1:45																	0
2:00																	0
2:15																	0
2:30																	0
2:45																	0
3:00																	0
3:15																	0
3:30																	0
3:45																	0
4:00																	0
4:15																	0
4:30																	0
4:45																	0
5:00																	0
5:15																	0
5:30																	0
5:45																	0
6:00																	0
6:15																	0
6:30	0	0	0	0	0	0	0	0	0	0	0	0	0	0	0	0	0
6:45	0	0	0	0	0	0	0	0	0	0	0	0	0	0	0	0	0
7:00	0	0	0	0	0	0	0	0	0	0	0	0	0	0	0	0	0
7:15	0	0	0	0	0	0	0	0	0	0	0	0	0	0	0	0	0
7:30	0	0	0	0	0	0	0	0	0	0	0	0	0	0	0	0	0
7:45	0	0	0	0	0	0	0	0	0	0	0	0	0	0	0	0	0
8:00	0	0	0	0	0	0	0	0	0	0	0	0	0	0	0	0	0
8:15	0	0	0	0	0	0	0	0	0	0	0	0	0	0	0	0	0
8:30																	0
8:45																	0
9:00																	0
9:15																	0
9:30																	0
9:45																	0
10:00																	0
10:15																	0
10:30																	0
10:45																	0
11:00	0	0	0	0	0	0	0	0	0	0	0	0	0	0	0	0	0
11:15	0	0	0	0	0	0	0	0	0	0	0	0	0	0	0	0	0
11:30	0	0	0	0	0	0	0	0	0	0	0	0	0	0	0	0	0
11:45	0	0	0	0	0	0	0	0	0	0	0	0	0	0	0	0	0
12:00	0	0	0	0	0	0	0	0	0	0	0	0	0	0	0	0	0
12:15	0	0	0	0	0	0	0	0	0	0	0	0	0	0	0	0	0
12:30	0	0	0	0	0	0	0	0	0	0	0	0	0	0	0	0	0
12:45	0	0	1	0	0	0	0	0	0	0	0	0	0	0	0	0	1
13:00																	0
13:15																	0
13:30																	0
13:45																	0
14:00																	0
14:15																	0
14:30																	0
14:45																	0
15:00																	0
15:15																	0
15:30																	0
15:45																	0
16:00	0	0	1	0	0	0	0	0	0	0	0	0	0	0	0	0	1
16:15	0	0	0	0	0	0	0	0	0	0	0	0	0	0	0	0	0
16:30	0	0	0	0	0	0	0	0	0	0	0	0	0	0	0	0	0
16:45	0	0	0	0	0	0	1	0	0	0	0	0	0	0	0	0	1
17:00	0	0	0	0	0	0	0	0	0	0	0	0	0	0	0	0	0
17:15	0	0	0	0	0	0	0	0	0	0	0	0	0	0	0	0	0
17:30	0	1	0	0	0	0	0	0	0	0	0	0	1	0	0	0	2
17:45	0	0	0	0	0	0	0	0	0	0	0	0	0	0	0	0	0
18:00																	0
18:15																	0
18:30																	0
18:45																	0
19:00																	0
19:15																	0
19:30																	0
19:45																	0
20:00																	0
20:15																	0
20:30																	0
20:45																	0
21:00																	0
21:15																	0
21:30																	0
21:45																	0
22:00																	0
22:15																	0
22:30																	0
22:45																	0
23:00																	0
23:15																	0
23:30																	0
23:45																	0
Total	0	1	2	0	0	0	0	1	0	0	0	0	0	2	0	0	6
AM Peak Hr:																	7:15
Pk Vol	0	0	0	0	0	0	0	0	0	0	0	0	0	0	0	1	0
PHF	n/a	n/a	n/a	n/a	n/a	n/a	n/a	n/a	n/a	n/a	n/a	n/a	n/a	n/a	n/a	0.250	n/a
MID Peak Hr:																	11:45
Pk Vol	0	0	0	0	0	0	0	0	0	0	0	0	0	0	0	0	0
PHF	n/a	n/a	n/a	n/a	n/a	n/a	n/a	n/a	n/a	n/a	n/a	n/a	n/a	n/a	n/a	n/a	n/a
PM Peak Hr:																	16:45
Pk Vol	0	1	0	0	0	0	0	1	0	0	0	0	0	1	0	0	3
PHF	n/a	0.250	n/a	n/a	n/a	n/a	n/a	0.250	n/a	n/a	n/a	n/a	n/a	0.250	n/a	n/a	0.375

Intersection ID: 1805117
Count Date: 11/29/2018

7TH AVE & W CAMELBACK RD

From North (SB) From East (WB) From South (NB) From West (EB) INTSEC
7TH AVE W CAMELBACK RD 7TH AVE W CAMELBACK RD

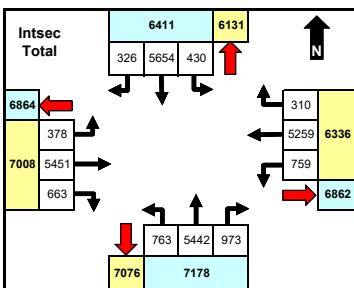
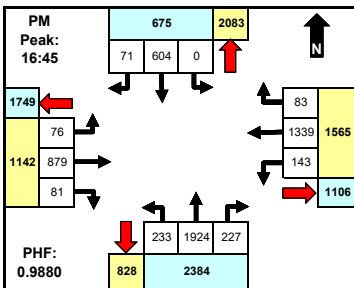
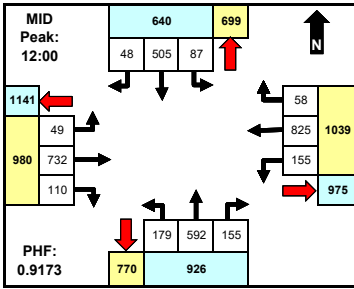
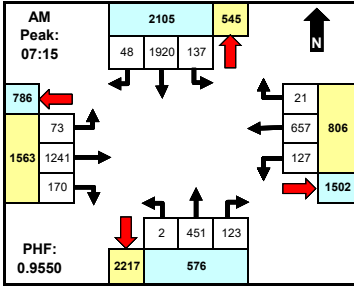

	North		East		South		West		Total
	App	Dep	App	Dep	App	Dep	App	Dep	
AM	2105	545	806	1502	576	2217	1563	786	5050
MID	640	699	1039	975	926	770	980	1141	3885
PM	675	2083	1565	1106	2384	828	1142	1749	5766
Total	6411	6131	6336	6862	7178	7076	7008	6864	26933

Time	From North (SB)				From East (WB)				From South (NB)				From West (EB)				INTSEC
	LT	Thru	RT	U	LT	Thru	RT	U	LT	Thru	RT	U	LT	Thru	RT	U	TOTAL
0:00																	0
0:15																	0
0:30																	0
0:45																	0
1:00																	0
1:15																	0
1:30																	0
1:45																	0
2:00																	0
2:15																	0
2:30																	0
2:45																	0
3:00																	0
3:15																	0
3:30																	0
3:45																	0
4:00																	0
4:15																	0
4:30																	0
4:45																	0
5:00																	0
5:15																	0
5:30																	0
5:45																	0
6:00																	0
6:15																	0
6:30	33	307	13	0	9	94	5	0	0	50	18	0	8	229	21	17	804
6:45	35	401	11	0	17	73	5	0	0	54	22	0	9	287	32	8	954
7:00	33	391	15	0	22	120	3	0	0	83	25	0	10	305	31	19	1057
7:15	44	473	15	0	22	154	4	0	2	106	31	0	12	313	32	12	1220
7:30	35	497	13	0	35	151	7	0	0	123	39	0	18	348	38	18	1322
7:45	33	479	5	0	29	140	7	0	0	110	24	0	25	310	54	26	1242
8:00	25	471	15	0	41	212	3	1	0	112	29	0	18	270	46	23	1266
8:15	17	437	6	0	39	150	5	0	1	115	22	0	22	226	39	28	1107
8:30																	0
8:45																	0
9:00																	0
9:15																	0
9:30																	0
9:45																	0
10:00																	0
10:15																	0
10:30																	0
10:45																	0
11:00	17	122	12	0	26	186	10	1	35	124	34	0	9	179	29	17	801
11:15	13	102	8	0	27	166	7	0	31	134	43	0	16	197	21	26	791
11:30	20	111	20	0	25	174	13	0	41	107	47	0	12	212	26	14	823
11:45	27	127	7	0	30	182	20	2	29	140	46	0	15	200	26	15	866
12:00	19	97	17	0	35	203	15	0	41	149	34	0	8	196	23	20	857
12:15	17	106	11	0	39	189	14	1	35	124	37	0	13	192	32	26	836
12:30	27	153	7	0	44	241	17	0	56	169	40	0	11	169	27	16	977
12:45	24	149	13	0	37	192	12	0	47	150	44	0	17	175	28	27	915
13:00																	0
13:15																	0
13:30																	0
13:45																	0
14:00																	0
14:15																	0
14:30																	0
14:45																	0
15:00																	0
15:15																	0
15:30																	0
15:45																	0
16:00	4	136	13	0	31	340	20	1	59	356	45	0	23	173	17	27	1245
16:15	1	154	22	0	37	369	19	0	54	466	62	0	15	180	16	15	1410
16:30	3	149	14	0	33	268	21	1	60	420	60	0	22	212	23	22	1308
16:45	0	134	9	0	31	350	20	0	41	468	65	0	13	268	15	33	1447
17:00	0	153	22	0	36	345	24	0	58	490	67	0	22	175	18	28	1438
17:15	0	157	22	0	42	338	17	0	61	505	46	0	20	215	16	20	1459
17:30	0	160	18	0	34	306	22	0	73	461	49	0	21	221	32	25	1422
17:45	3	188	18	1	38	316	20	1	39	426	44	0	19	198	21	34	1366
18:00																	0
18:15																	0
18:30																	0
18:45																	0
19:00																	0
19:15																	0
19:30																	0
19:45																	0
20:00																	0
20:15																	0
20:30																	0
20:45																	0
21:00																	0
21:15																	0
21:30																	0
21:45																	0
22:00																	0
22:15																	0
22:30																	0
22:45																	0
23:00																	0
23:15																	0
23:30																	0
23:45																	0
Total	430	5654	326	1	759	5259	310	8	763	5442	973	0	378	5451	663	516	26933

Comments

Unless shown otherwise, MID period defined as 10:00 AM - 2:00 PM. Peaks defined based on total intersection volume for all vehicle types.

AM Peak Hr: 7:15																	
PK Vol	137	1920	48	0	127	657	21	1	2	451	123	0	73	1241	170	79	5050
PHF	0.778	0.966	0.800	n/a	0.774	0.775	0.750	0.250	0.250	0.917	0.788	n/a	0.730	0.892	0.787	0.760	0.955
MID Peak Hr: 12:00																	
PK Vol	87	505	48	0	155	825	58	1	179	592	155	0	49	732	110	89	3585
PHF	0.806	0.825	0.705	n/a	0.881	0.856	0.853	0.250	0.799	0.876	0.881	n/a	0.721	0.934	0.859	0.824	0.917
PM Peak Hr: 16:45																	
PK Vol	0	604	71	0	143	1339	83	0	233	1924	227	0	76	879	81	106	5765
PH																	

Intersection ID: 1805117
Count Date: 11/29/2018

7TH AVE & W CAMELBACK RD

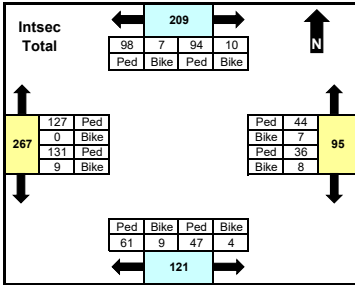
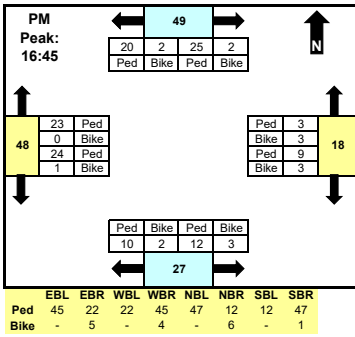
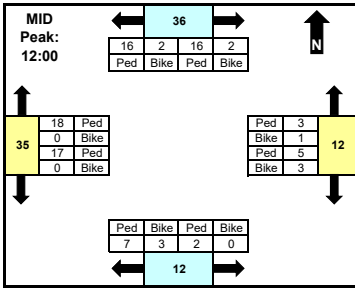
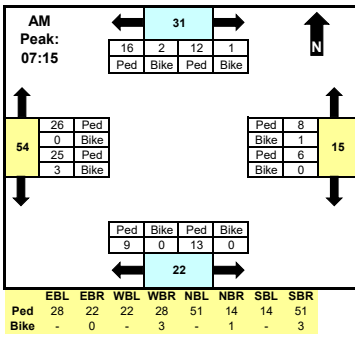

	North		East		South		West		Total
	CW	CCW	CW	CCW	CW	CCW	CW	CCW	
AM	13	18	6	9	9	13	26	28	122
MID	18	18	8	4	10	2	18	17	95
PM	27	22	12	6	12	15	23	25	142
Total	104	105	44	51	70	51	127	140	692

CW = Clockwise
CCW = Counter-clockwise

Comments
Unless shown otherwise, MID period defined as 10:00 AM - 2:00 PM. Crosswalk peaks defined based on total intersection volume for all vehicle types.

Time	North Leg		East Leg		South Leg		West Leg		INTSEC	TOTAL							
	CW	CCW	CW	CCW	CW	CCW	CW	CCW									
0:00										0							
0:15										0							
0:30										0							
0:45										0							
1:00										0							
1:15										0							
1:30										0							
1:45										0							
2:00										0							
2:15										0							
2:30										0							
2:45										0							
3:00										0							
3:15										0							
3:30										0							
3:45										0							
4:00										0							
4:15										0							
4:30										0							
4:45										0							
5:00										0							
5:15										0							
5:30										0							
5:45										0							
6:00										0							
6:15										0							
6:30	3	1	0	0	0	0	2	0	1	0	2	2					
6:45	3	0	6	0	0	0	0	1	0	1	0	2	0	5	0	17	
7:00	4	0	3	0	2	0	4	1	1	0	1	0	4	0	4	0	24
7:15	1	0	6	0	1	0	2	0	0	4	0	3	0	8	0	25	
7:30	2	0	4	1	1	0	1	0	4	0	3	0	8	0	6	0	30
7:45	5	1	6	0	1	0	2	1	1	0	2	0	5	0	4	2	30
8:00	4	0	0	1	3	0	3	0	4	0	4	0	10	0	7	1	37
8:15	1	1	4	0	1	0	7	0	5	1	0	0	3	0	7	1	31
8:30																	0
8:45																	0
9:00																	0
9:15																	0
9:30																	0
9:45																	0
10:00																	0
10:15																	0
10:30																	0
10:45																	0
11:00	4	0	4	0	1	0	2	0	4	0	0	0	3	0	4	0	22
11:15	3	0	7	0	1	0	2	0	7	2	0	0	8	0	6	0	36
11:30	6	0	1	0	2	0	1	0	4	1	3	0	7	0	5	0	30
11:45	3	1	4	0	1	0	0	0	0	0	1	0	1	0	2	0	13
12:00	8	1	7	1	1	1	1	1	6	2	0	0	6	0	4	0	39
12:15	2	1	1	1	0	0	2	0	0	1	1	0	5	0	5	0	19
12:30	2	0	1	0	2	1	0	0	0	0	0	0	1	0	5	0	12
12:45	4	0	7	0	2	1	0	0	1	0	1	0	6	0	3	0	25
13:00																	0
13:15																	0
13:30																	0
13:45																	0
14:00																	0
14:15																	0
14:30																	0
14:45																	0
15:00																	0
15:15																	0
15:30																	0
15:45																	0
16:00	3	0	5	0	0	0	0	0	2	0	3	1	10	0	11	0	35
16:15	4	1	3	1	2	0	2	0	0	0	4	0	4	0	6	1	28
16:30	5	1	5	0	1	1	3	1	6	0	4	0	9	0	9	1	46
16:45	5	0	5	1	2	0	0	0	1	0	2	1	6	0	7	0	30
17:00	9	0	10	1	2	1	3	0	5	0	2	0	5	0	7	0	45
17:15	6	2	3	0	4	1	0	3	2	2	6	2	8	0	6	1	46
17:30	5	0	2	0	1	1	0	0	2	0	2	0	4	0	4	0	21
17:45	2	0	4	0	5	1	7	0	4	0	1	0	5	0	4	0	33
18:00																	0
18:15																	0
18:30																	0
18:45																	0
19:00																	0
19:15																	0
19:30																	0
19:45																	0
20:00																	0
20:15																	0
20:30																	0
20:45																	0
21:00																	0
21:15																	0
21:30																	0
21:45																	0
22:00																	0
22:15																	0
22:30																	0
22:45																	0
23:00																	0
23:15																	0
23:30																	0
23:45																	0
Total	94	10	98	7	36	8	44	7	61	9	47	4	127	0	131	9	692
AM Peak Hr:																	7:15
PK Vol	12	1	16	2	6	0	8	1	9	0	13	0	26	0	25	3	122
MID Peak Hr:																	12:00
PK Vol	16	2	16	2	5	3	3	1	7	3	2	0	18	0	17	0	95
PM Peak Hr:																	16:45
PK Vol	25	2	20	2	9	3	3	3	10	2	12	3	23	0	24	1	142

Intersection ID: 1805117
Count Date: 11/29/2018

7TH AVE & W CAMELBACK RD

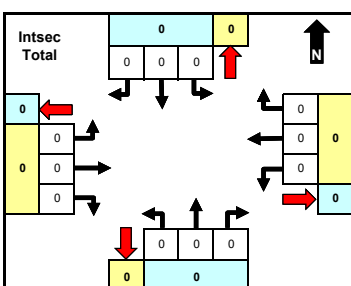
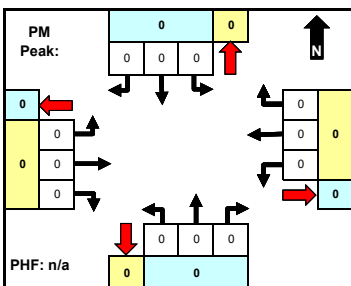
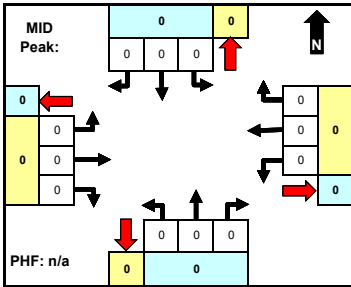
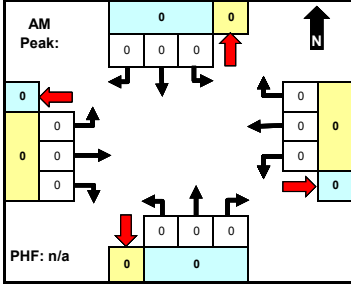

	North		East		South		West		Total
	App	Dep	App	Dep	App	Dep	App	Dep	
AM	0	0	0	0	0	0	0	0	0
MID	0	0	0	0	0	0	0	0	0
PM	0	0	0	0	0	0	0	0	0
Total	0	0	0	0	0	0	0	0	0

Comments
Unless shown otherwise, MID period defined as 10:00 AM - 2:00 PM. Peaks defined based on total intersection volume for all vehicle types.

Time	From North (SB)				From East (WB)				From South (NB)				From West (EB)				INTSEC	TOTAL
	7TH AVE				W CAMELBACK RD				7TH AVE				W CAMELBACK RD					
	LT	Thru	RT	U	LT	Thru	RT	U	LT	Thru	RT	U	LT	Thru	RT	U		
0:00																	0	
0:15																	0	
0:30																	0	
0:45																	0	
1:00																	0	
1:15																	0	
1:30																	0	
1:45																	0	
2:00																	0	
2:15																	0	
2:30																	0	
2:45																	0	
3:00																	0	
3:15																	0	
3:30																	0	
3:45																	0	
4:00																	0	
4:15																	0	
4:30																	0	
4:45																	0	
5:00																	0	
5:15																	0	
5:30																	0	
5:45																	0	
6:00																	0	
6:15																	0	
6:30	0	0	0	0	0	0	0	0	0	0	0	0	0	0	0	0	0	
6:45	0	0	0	0	0	0	0	0	0	0	0	0	0	0	0	0	0	
7:00	0	0	0	0	0	0	0	0	0	0	0	0	0	0	0	0	0	
7:15	0	0	0	0	0	0	0	0	0	0	0	0	0	0	0	0	0	
7:30	0	0	0	0	0	0	0	0	0	0	0	0	0	0	0	0	0	
7:45	0	0	0	0	0	0	0	0	0	0	0	0	0	0	0	0	0	
8:00	0	0	0	0	0	0	0	0	0	0	0	0	0	0	0	0	0	
8:15	0	0	0	0	0	0	0	0	0	0	0	0	0	0	0	0	0	
8:30																	0	
8:45																	0	
9:00																	0	
9:15																	0	
9:30																	0	
9:45																	0	
10:00																	0	
10:15																	0	
10:30																	0	
10:45																	0	
11:00	0	0	0	0	0	0	0	0	0	0	0	0	0	0	0	0	0	
11:15	0	0	0	0	0	0	0	0	0	0	0	0	0	0	0	0	0	
11:30	0	0	0	0	0	0	0	0	0	0	0	0	0	0	0	0	0	
11:45	0	0	0	0	0	0	0	0	0	0	0	0	0	0	0	0	0	
12:00	0	0	0	0	0	0	0	0	0	0	0	0	0	0	0	0	0	
12:15	0	0	0	0	0	0	0	0	0	0	0	0	0	0	0	0	0	
12:30	0	0	0	0	0	0	0	0	0	0	0	0	0	0	0	0	0	
12:45	0	0	0	0	0	0	0	0	0	0	0	0	0	0	0	0	0	
13:00																	0	
13:15																	0	
13:30																	0	
13:45																	0	
14:00																	0	
14:15																	0	
14:30																	0	
14:45																	0	
15:00																	0	
15:15																	0	
15:30																	0	
15:45																	0	
16:00	0	0	0	0	0	0	0	0	0	0	0	0	0	0	0	0	0	
16:15	0	0	0	0	0	0	0	0	0	0	0	0	0	0	0	0	0	
16:30	0	0	0	0	0	0	0	0	0	0	0	0	0	0	0	0	0	
16:45	0	0	0	0	0	0	0	0	0	0	0	0	0	0	0	0	0	
17:00	0	0	0	0	0	0	0	0	0	0	0	0	0	0	0	0	0	
17:15	0	0	0	0	0	0	0	0	0	0	0	0	0	0	0	0	0	
17:30	0	0	0	0	0	0	0	0	0	0	0	0	0	0	0	0	0	
17:45	0	0	0	0	0	0	0	0	0	0	0	0	0	0	0	0	0	
18:00																	0	
18:15																	0	
18:30																	0	
18:45																	0	
19:00																	0	
19:15																	0	
19:30																	0	
19:45																	0	
20:00																	0	
20:15																	0	
20:30																	0	
20:45																	0	
21:00																	0	
21:15																	0	
21:30																	0	
21:45																	0	
22:00																	0	
22:15																	0	
22:30																	0	
22:45																	0	
23:00																	0	
23:15																	0	
23:30																	0	
23:45																	0	
Total	0	0	0	0	0	0	0	0	0	0	0	0	0	0	0	0	0	
AM Peak Hr:																	7:15	
Pk Vol	0	0	0	0	0	0	0	0	0	0	0	0	0	0	0	0	0	
PHF	n/a	n/a	n/a	n/a	n/a	n/a	n/a	n/a	n/a	n/a	n/a	n/a	n/a	n/a	n/a	n/a	n/a	
MID Peak Hr:																	12:00	
Pk Vol	0	0	0	0	0	0	0	0	0	0	0	0	0	0	0	0	0	
PHF	n/a	n/a	n/a	n/a	n/a	n/a	n/a	n/a	n/a	n/a	n/a	n/a	n/a	n/a	n/a	n/a	n/a	
PM Peak Hr:																	16:45	
Pk Vol	0	0	0	0	0	0	0	0	0	0	0	0	0	0	0	0	0	
PHF	n/a	n/a	n/a	n/a	n/a	n/a	n/a	n/a	n/a	n/a	n/a	n/a	n/a	n/a	n/a	n/a	n/a	

Intersection ID: 1805116
Count Date: 11/27/2018

N 7TH AVE & W MISSOURI AVE

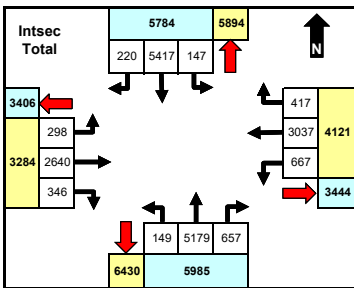
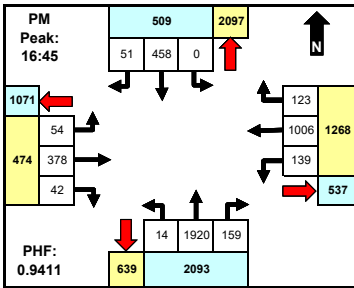
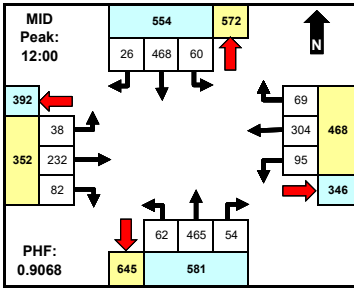
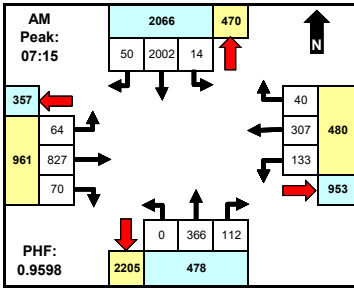

	North		East		South		West		Total
	App	Dep	App	Dep	App	Dep	App	Dep	
AM	2066	470	480	953	478	2205	961	357	3985
MID	554	572	468	346	581	645	352	392	1955
PM	509	2097	1268	537	2093	639	474	1071	4344
Total	5784	5894	4121	3444	5985	6430	3284	3406	19174

Comments

Unless shown otherwise, MID period defined as 10:00 AM - 2:00 PM. Peaks defined based on total intersection volume for all vehicle types.

Time	From North (SB)				From East (WB)				From South (NB)				From West (EB)				INTSEC	TOTAL
	N 7TH AVE	W MISSOURI AVE	N 7TH AVE	W MISSOURI AVE	N 7TH AVE	W MISSOURI AVE	N 7TH AVE	W MISSOURI AVE	N 7TH AVE	W MISSOURI AVE	N 7TH AVE	W MISSOURI AVE	N 7TH AVE	W MISSOURI AVE				
0:00																	0	
0:15																	0	
0:30																	0	
0:45																	0	
1:00																	0	
1:15																	0	
1:30																	0	
1:45																	0	
2:00																	0	
2:15																	0	
2:30																	0	
2:45																	0	
3:00																	0	
3:15																	0	
3:30																	0	
3:45																	0	
4:00																	0	
4:15																	0	
4:30																	0	
4:45																	0	
5:00																	0	
5:15																	0	
5:30																	0	
5:45																	0	
6:00																	0	
6:15																	0	
6:30	2	332	5	0	16	19	3	0	0	38	17	0	10	106	9	0	557	
6:45	4	373	3	0	17	46	6	0	0	55	19	0	14	184	9	0	730	
7:00	3	496	9	0	27	48	5	0	0	68	27	0	11	179	14	0	887	
7:15	3	480	9	0	29	70	3	0	0	65	31	0	14	260	13	0	977	
7:30	7	527	14	0	33	63	11	0	0	103	31	0	14	219	16	0	1038	
7:45	2	480	12	0	32	89	13	0	0	96	21	0	16	208	22	0	991	
8:00	2	515	15	0	39	85	13	0	0	102	29	0	20	140	19	0	979	
8:15	2	403	12	0	38	86	15	0	0	101	65	0	13	178	21	0	934	
8:30																	0	
8:45																	0	
9:00																	0	
9:15																	0	
9:30																	0	
9:45																	0	
10:00																	0	
10:15																	0	
10:30																	0	
10:45																	0	
11:00	14	113	10	0	25	66	13	0	18	128	21	0	13	51	18	0	490	
11:15	16	98	7	0	23	62	10	0	7	113	16	0	7	55	17	0	431	
11:30	16	89	4	0	16	67	12	0	24	126	17	0	12	54	16	0	453	
11:45	16	120	7	0	17	68	14	0	15	119	21	0	9	71	6	0	483	
12:00	16	126	5	0	31	90	14	0	19	126	13	0	9	67	23	0	539	
12:15	16	125	10	0	22	68	17	0	15	100	15	0	6	45	21	0	460	
12:30	16	122	4	0	20	68	18	0	13	115	16	0	7	53	19	0	471	
12:45	12	95	7	0	22	78	20	0	15	124	10	0	16	67	19	0	485	
13:00																	0	
13:15																	0	
13:30																	0	
13:45																	0	
14:00																	0	
14:15																	0	
14:30																	0	
14:45																	0	
15:00																	0	
15:15																	0	
15:30																	0	
15:45																	0	
16:00	0	107	12	0	35	253	23	0	1	336	26	0	17	89	11	0	910	
16:15	0	109	6	0	30	238	24	0	1	475	46	0	12	76	7	0	1024	
16:30	0	118	8	0	25	262	27	0	1	433	25	0	17	89	12	0	1017	
16:45	0	103	8	0	24	232	29	0	4	524	40	0	8	91	5	0	1068	
17:00	0	102	17	0	31	267	28	0	4	432	33	0	14	110	11	0	1049	
17:15	0	139	14	0	35	249	35	0	5	519	46	0	12	93	7	0	1154	
17:30	0	114	12	0	49	258	31	0	1	445	40	0	20	84	19	0	1073	
17:45	0	131	10	0	31	205	33	0	6	436	32	0	7	71	12	0	974	
18:00																	0	
18:15																	0	
18:30																	0	
18:45																	0	
19:00																	0	
19:15																	0	
19:30																	0	
19:45																	0	
20:00																	0	
20:15																	0	
20:30																	0	
20:45																	0	
21:00																	0	
21:15																	0	
21:30																	0	
21:45																	0	
22:00																	0	
22:15																	0	
22:30																	0	
22:45																	0	
23:00																	0	
23:15																	0	
23:30																	0	
23:45																	0	
Total	147	5417	220	0	667	3037	417	0	149	5179	657	0	298	2640	346	0	19174	
AM Peak Hr:																	7:15	
PK Vol	14	2002	50	0	133	307	40	0	0	366	112	0	64	827	70	0	3985	
PHF	0.500	0.950	0.833	n/a	0.853	0.862	0.769	n/a	n/a	0.888	0.903	n/a	0.800	0.795	0.795	n/a	0.960	
MID Peak Hr:																	12:00	
PK Vol	60	468	26	0	95	304	69	0	62	465	64	0	38	232	82	0	1955	
PHF	0.938	0.929	0.650	n/a	0.766	0.844	0.863	n/a	0.816	0.923	0.844	n/a	0.594	0.866	0.891	n/a	0.907	
PM Peak Hr:																	16:45	
PK Vol	0	458	51	0	139	1006	123	0	14	1920	169	0	54	378	42	0	4344	
PHF	n/a	0.824	0.750	n/a	0.709	0.942	0.879	n/a	0.700	0.916	0.864	n/a	0.675	0.858	0.553	n/a	0.941	

Intersection ID: 1805116
Count Date: 11/27/2018

N 7TH AVE & W MISSOURI AVE

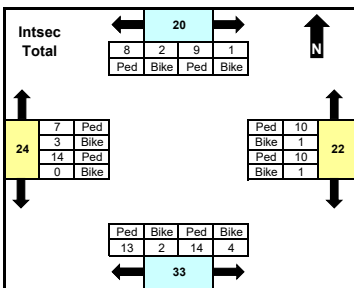
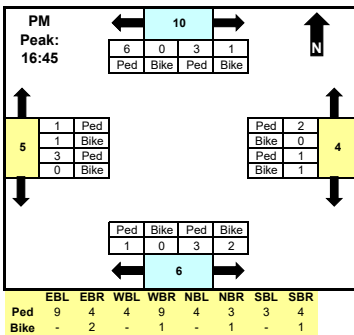
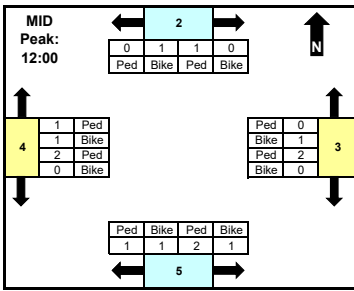
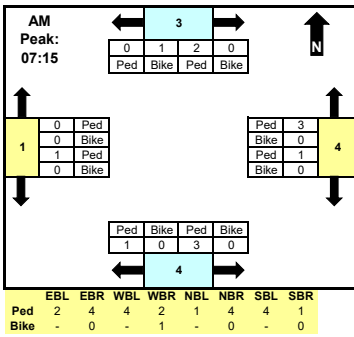

	North		East		South		West		Total
	CW	CCW	CW	CCW	CW	CCW	CW	CCW	
AM	2	1	1	3	1	3	0	1	12
MID	1	1	2	1	2	3	2	2	14
PM	4	6	2	2	1	5	2	3	25
Total	10	10	11	11	15	18	10	14	99

CW = Clockwise
CCW = Counter-clockwise

Comments

Unless shown otherwise, MID period defined as 10:00 AM - 2:00 PM. Crosswalk peaks defined based on total intersection volume for all vehicle types.

Time	North Leg		East Leg		South Leg		West Leg		INTSEC	TOTAL							
	CW	CCW	CW	CCW	CW	CCW	CW	CCW									
0:00										0							
0:15										0							
0:30										0							
0:45										0							
1:00										0							
1:15										0							
1:30										0							
1:45										0							
2:00										0							
2:15										0							
2:30										0							
2:45										0							
3:00										0							
3:15										0							
3:30										0							
3:45										0							
4:00										0							
4:15										0							
4:30										0							
4:45										0							
5:00										0							
5:15										0							
5:30										0							
5:45										0							
6:00										0							
6:15										0							
6:30	0	0	0	0	0	0	0	0	1	0							
6:45	0	0	0	0	2	0	2	0	4	12							
7:00	0	0	0	0	0	1	0	0	0	1							
7:15	1	0	0	1	0	2	0	0	0	6							
7:30	0	0	0	0	0	0	0	0	0	0							
7:45	1	0	0	1	0	0	1	0	0	3							
8:00	0	0	0	0	0	1	0	0	0	1							
8:15	0	0	0	0	0	0	0	0	0	0							
8:30										0							
8:45										0							
9:00										0							
9:15										0							
9:30										0							
9:45										0							
10:00										0							
10:15										0							
10:30										0							
10:45										0							
11:00	0	0	0	0	1	0	1	0	1	4							
11:15	0	0	0	0	0	0	0	0	1	1							
11:30	0	0	0	0	0	1	0	0	0	2							
11:45	0	0	1	0	1	0	0	0	2	6							
12:00	1	0	0	2	0	0	1	0	0	6							
12:15	0	0	0	1	0	0	1	0	0	4							
12:30	0	0	0	0	0	0	0	0	1	2							
12:45	0	0	0	0	0	0	1	0	0	2							
13:00										0							
13:15										0							
13:30										0							
13:45										0							
14:00										0							
14:15										0							
14:30										0							
14:45										0							
15:00										0							
15:15										0							
15:30										0							
15:45										0							
16:00	1	0	1	0	2	0	0	0	0	5							
16:15	0	0	0	0	0	0	0	2	0	5							
16:30	2	0	0	0	0	0	0	1	0	6							
16:45	2	0	2	0	0	0	0	0	1	5							
17:00	0	0	1	0	1	0	0	0	0	3							
17:15	0	0	0	0	2	0	0	3	2	8							
17:30	1	1	3	0	1	0	0	0	0	9							
17:45	0	0	0	0	0	0	0	1	0	3							
18:00										0							
18:15										0							
18:30										0							
18:45										0							
19:00										0							
19:15										0							
19:30										0							
19:45										0							
20:00										0							
20:15										0							
20:30										0							
20:45										0							
21:00										0							
21:15										0							
21:30										0							
21:45										0							
22:00										0							
22:15										0							
22:30										0							
22:45										0							
23:00										0							
23:15										0							
23:30										0							
23:45										0							
Total	9	1	8	2	10	1	10	1	13	2	14	4	7	3	14	0	99
AM Peak Hr:																	7:15
PK Vol	2	0	0	1	1	0	3	0	1	0	3	0	0	1	0	12	
MID Peak Hr:																12:00	
PK Vol	1	0	0	1	2	0	0	1	1	1	2	1	1	2	0	14	
PM Peak Hr:																16:45	
PK Vol	3	1	6	0	1	1	2	0	1	0	3	2	1	1	3	25	

Intersection ID: 1805116
Count Date: 11/27/2018

N 7TH AVE & W MISSOURI AVE

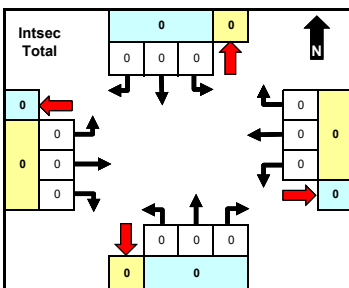
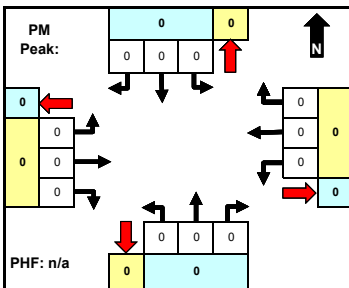
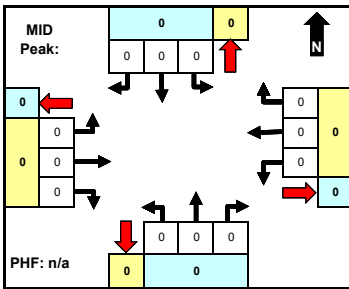
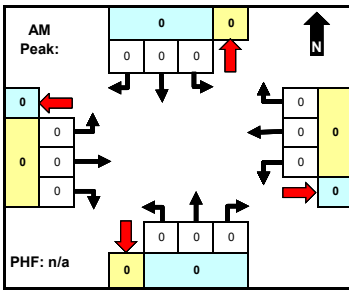

	North		East		South		West		Total
	App	Dep	App	Dep	App	Dep	App	Dep	
AM	0	0	0	0	0	0	0	0	0
MID	0	0	0	0	0	0	0	0	0
PM	0	0	0	0	0	0	0	0	0
Total	0	0	0	0	0	0	0	0	0

Comments
Unless shown otherwise, MID period defined as 10:00 AM - 2:00 PM. Peaks defined based on total intersection volume for all vehicle types.

Time	From North (SB) N 7TH AVE				From East (WB) W MISSOURI AVE				From South (NB) N 7TH AVE				From West (EB) W MISSOURI AVE				INTSEC TOTAL
	LT	Thru	RT	U	LT	Thru	RT	U	LT	Thru	RT	U	LT	Thru	RT	U	
	0:00																
0:15																	0
0:30																	0
0:45																	0
1:00																	0
1:15																	0
1:30																	0
1:45																	0
2:00																	0
2:15																	0
2:30																	0
2:45																	0
3:00																	0
3:15																	0
3:30																	0
3:45																	0
4:00																	0
4:15																	0
4:30																	0
4:45																	0
5:00																	0
5:15																	0
5:30																	0
5:45																	0
6:00																	0
6:15																	0
6:30	0	0	0	0	0	0	0	0	0	0	0	0	0	0	0	0	0
6:45	0	0	0	0	0	0	0	0	0	0	0	0	0	0	0	0	0
7:00	0	0	0	0	0	0	0	0	0	0	0	0	0	0	0	0	0
7:15	0	0	0	0	0	0	0	0	0	0	0	0	0	0	0	0	0
7:30	0	0	0	0	0	0	0	0	0	0	0	0	0	0	0	0	0
7:45	0	0	0	0	0	0	0	0	0	0	0	0	0	0	0	0	0
8:00	0	0	0	0	0	0	0	0	0	0	0	0	0	0	0	0	0
8:15	0	0	0	0	0	0	0	0	0	0	0	0	0	0	0	0	0
8:30																	0
8:45																	0
9:00																	0
9:15																	0
9:30																	0
9:45																	0
10:00																	0
10:15																	0
10:30																	0
10:45																	0
11:00	0	0	0	0	0	0	0	0	0	0	0	0	0	0	0	0	0
11:15	0	0	0	0	0	0	0	0	0	0	0	0	0	0	0	0	0
11:30	0	0	0	0	0	0	0	0	0	0	0	0	0	0	0	0	0
11:45	0	0	0	0	0	0	0	0	0	0	0	0	0	0	0	0	0
12:00	0	0	0	0	0	0	0	0	0	0	0	0	0	0	0	0	0
12:15	0	0	0	0	0	0	0	0	0	0	0	0	0	0	0	0	0
12:30	0	0	0	0	0	0	0	0	0	0	0	0	0	0	0	0	0
12:45	0	0	0	0	0	0	0	0	0	0	0	0	0	0	0	0	0
13:00																	0
13:15																	0
13:30																	0
13:45																	0
14:00																	0
14:15																	0
14:30																	0
14:45																	0
15:00																	0
15:15																	0
15:30																	0
15:45																	0
16:00	0	0	0	0	0	0	0	0	0	0	0	0	0	0	0	0	0
16:15	0	0	0	0	0	0	0	0	0	0	0	0	0	0	0	0	0
16:30	0	0	0	0	0	0	0	0	0	0	0	0	0	0	0	0	0
16:45	0	0	0	0	0	0	0	0	0	0	0	0	0	0	0	0	0
17:00	0	0	0	0	0	0	0	0	0	0	0	0	0	0	0	0	0
17:15	0	0	0	0	0	0	0	0	0	0	0	0	0	0	0	0	0
17:30	0	0	0	0	0	0	0	0	0	0	0	0	0	0	0	0	0
17:45	0	0	0	0	0	0	0	0	0	0	0	0	0	0	0	0	0
18:00																	0
18:15																	0
18:30																	0
18:45																	0
19:00																	0
19:15																	0
19:30																	0
19:45																	0
20:00																	0
20:15																	0
20:30																	0
20:45																	0
21:00																	0
21:15																	0
21:30																	0
21:45																	0
22:00																	0
22:15																	0
22:30																	0
22:45																	0
23:00																	0
23:15																	0
23:30																	0
23:45																	0
Total	0	0	0	0	0	0	0	0	0	0	0	0	0	0	0	0	0
AM Peak Hr:																	7:15
Pk Vol	0	0	0	0	0	0	0	0	0	0	0	0	0	0	0	0	0
PHF	n/a	n/a	n/a	n/a	n/a	n/a	n/a	n/a	n/a	n/a	n/a	n/a	n/a	n/a	n/a	n/a	n/a
MID Peak Hr:																	12:00
Pk Vol	0	0	0	0	0	0	0	0	0	0	0	0	0	0	0	0	0
PHF	n/a	n/a	n/a	n/a	n/a	n/a	n/a	n/a	n/a	n/a	n/a	n/a	n/a	n/a	n/a	n/a	n/a
PM Peak Hr:																	16:45
Pk Vol	0	0	0	0	0	0	0	0	0	0	0	0	0	0	0	0	0
PHF	n/a	n/a	n/a	n/a	n/a	n/a	n/a	n/a	n/a	n/a	n/a	n/a	n/a	n/a	n/a	n/a	n/a

Intersection ID: 1805115
Count Date: 11/27/2018

N 7TH AVE & W BETHANY HOME RD

From North (SB) From East (WB) From South (NB) From West (EB) INTSEC
N 7TH AVE W BETHANY HOME RD N 7TH AVE W BETHANY HOME RD

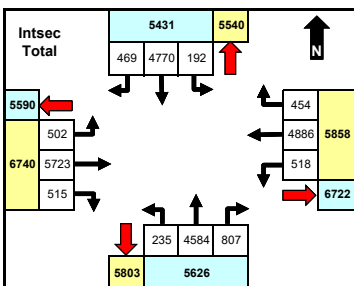
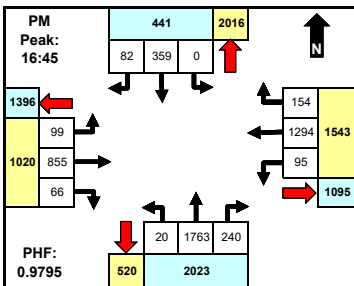
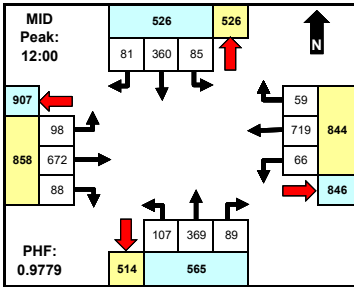
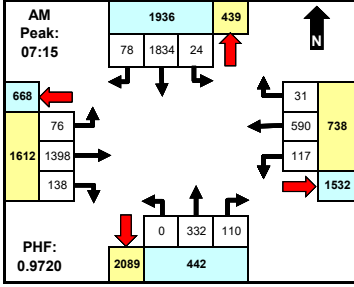

	North		East		South		West		Total
	App	Dep	App	Dep	App	Dep	App	Dep	
AM	1936	439	738	1532	442	2089	1612	668	4728
MID	526	526	844	846	565	514	858	907	2793
PM	441	2016	1543	1095	2023	520	1020	1396	5027
Total	5431	3540	5858	6722	5626	5803	6740	5590	23655

Comments

Unless shown otherwise, MID period defined as 10:00 AM - 2:00 PM. Peaks defined based on total intersection volume for all vehicle types.

Time	From North (SB)				From East (WB)				From South (NB)				From West (EB)				TOTAL
	LT	Thru	RT	U	LT	Thru	RT	U	LT	Thru	RT	U	LT	Thru	RT	U	
0:00																	0
0:15																	0
0:30																	0
0:45																	0
1:00																	0
1:15																	0
1:30																	0
1:45																	0
2:00																	0
2:15																	0
2:30																	0
2:45																	0
3:00																	0
3:15																	0
3:30																	0
3:45																	0
4:00																	0
4:15																	0
4:30																	0
4:45																	0
5:00																	0
5:15																	0
5:30																	0
5:45																	0
6:00																	0
6:15																	0
6:30	5	280	17	0	14	105	2	0	0	28	9	0	10	268	26	0	764
6:45	5	416	23	0	8	115	10	0	0	59	22	0	9	287	17	0	971
7:00	5	396	19	0	19	103	8	0	0	59	22	0	11	356	18	0	1016
7:15	10	493	17	0	31	157	3	0	0	56	29	0	13	349	28	0	1186
7:30	7	439	14	0	21	151	9	0	0	75	33	0	20	403	33	0	1205
7:45	6	485	23	0	41	159	8	0	0	110	25	0	14	514	31	0	1216
8:00	1	417	24	0	24	123	11	0	0	91	23	0	29	332	46	0	1121
8:15	4	422	19	0	27	129	9	0	0	103	21	0	19	273	27	0	1053
8:30																	0
8:45																	0
9:00																	0
9:15																	0
9:30																	0
9:45																	0
10:00																	0
10:15																	0
10:30																	0
10:45																	0
11:00	10	92	17	0	16	178	8	0	24	92	29	0	20	181	21	0	688
11:15	17	76	20	0	19	137	15	0	20	82	26	0	16	178	18	0	624
11:30	11	80	26	0	18	145	13	0	27	87	34	0	17	154	17	0	629
11:45	23	102	21	0	17	146	15	0	18	89	28	0	14	180	19	0	672
12:00	23	95	23	0	15	176	15	0	30	95	20	0	19	175	28	0	714
12:15	23	97	16	0	15	190	13	0	11	84	22	0	28	158	23	0	680
12:30	26	91	20	0	20	172	11	0	36	84	24	0	30	180	20	0	714
12:45	13	77	22	0	16	181	20	0	30	106	23	0	21	159	17	0	685
13:00																	0
13:15																	0
13:30																	0
13:45																	0
14:00																	0
14:15																	0
14:30																	0
14:45																	0
15:00																	0
15:15																	0
15:30																	0
15:45																	0
16:00	2	69	21	0	37	285	30	0	2	338	46	0	29	224	13	0	1096
16:15	0	81	21	0	21	352	21	0	3	405	37	0	30	242	11	0	1224
16:30	0	93	12	0	26	302	39	0	2	419	46	0	32	225	20	0	1216
16:45	0	86	18	0	24	341	31	0	1	447	58	0	22	180	10	0	1218
17:00	0	84	20	0	24	324	36	0	8	427	65	0	26	227	17	0	1258
17:15	0	100	23	0	25	317	44	0	3	438	63	0	29	208	18	0	1268
17:30	0	89	21	0	22	312	43	0	8	451	54	0	22	240	21	0	1283
17:45	1	110	12	0	18	286	40	0	12	359	48	0	22	230	16	0	1154
18:00																	0
18:15																	0
18:30																	0
18:45																	0
19:00																	0
19:15																	0
19:30																	0
19:45																	0
20:00																	0
20:15																	0
20:30																	0
20:45																	0
21:00																	0
21:15																	0
21:30																	0
21:45																	0
22:00																	0
22:15																	0
22:30																	0
22:45																	0
23:00																	0
23:15																	0
23:30																	0
23:45																	0
Total	192	4770	469	0	518	4886	454	0	235	4584	807	0	502	5723	515	0	23655
AM Peak Hr:																	7:15
PK Vol	24	1834	78	0	117	590	31	0	0	332	110	0	76	1398	138	0	4728
PHF	0.600	0.930	0.813	n/a	0.713	0.928	0.705	n/a	n/a	0.755	0.833	n/a	0.655	0.867	0.750	n/a	0.972
MID Peak Hr:																	12:00
PK Vol	85	360	81	0	65	719	59	0	107	369	89	0	98	672	88	0	2793
PHF	0.817	0.928	0.880	n/a	0.825	0.946	0.738	n/a	0.743	0.870	0.927	n/a	0.817	0.933	0.785	n/a	0.978
PM Peak Hr:																	16:45
PK Vol	0	359	82	0	95	1294	154	0	20	1763	240	0	99	855	66	0	5027
PHF	n/a	0.898	0.891	n/a	0.950	0.949	0.875	n/a	0.625	0.977	0.923	n/a	0.853	0.891	0.786	n/a	0.980



Intersection ID: 1805115
Count Date: 11/27/2018

N 7TH AVE & W BETHANY HOME RD

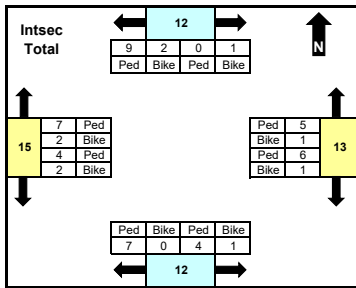
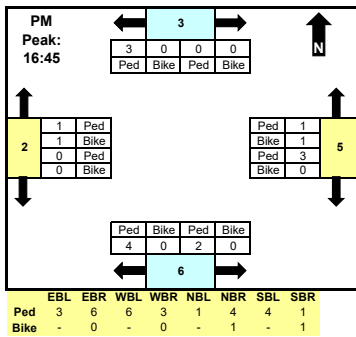
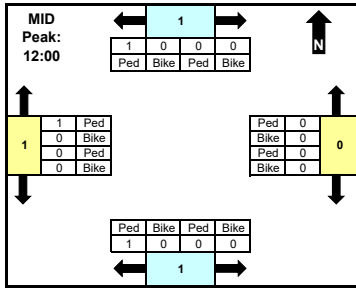
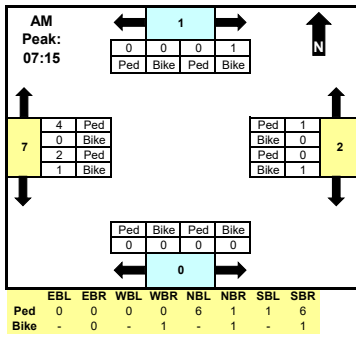

	North		East		South		West		Total
	CW	CCW	CW	CCW	CW	CCW	CW	CCW	
AM	1	0	1	1	0	0	4	3	10
MID	0	1	0	0	1	0	1	0	3
PM	0	3	3	2	4	2	2	0	16
Total	1	11	7	6	7	5	9	6	52

CW = Clockwise
CCW = Counter-clockwise

Comments
Unless shown otherwise, MID period defined as 10:00 AM - 2:00 PM. Crosswalk peaks defined based on total intersection volume for all vehicle types.

Time	North Leg		East Leg		South Leg		West Leg		INTSEC	TOTAL							
	CW	CCW	CW	CCW	CW	CCW	CW	CCW									
0:00										0							
0:15										0							
0:30										0							
0:45										0							
1:00										0							
1:15										0							
1:30										0							
1:45										0							
2:00										0							
2:15										0							
2:30										0							
2:45										0							
3:00										0							
3:15										0							
3:30										0							
3:45										0							
4:00										0							
4:15										0							
4:30										0							
4:45										0							
5:00										0							
5:15										0							
5:30										0							
5:45										0							
6:00										0							
6:15										0							
6:30	0	0	0	0	0	0	0	0	0	0							
6:45	0	0	0	0	0	0	0	0	0	0							
7:00	0	0	0	0	0	0	0	0	0	0							
7:15	0	0	0	0	0	1	0	0	0	0							
7:30	0	0	0	0	1	0	0	0	0	1							
7:45	0	1	0	0	0	0	0	0	4	2							
8:00	0	0	0	0	0	0	0	0	0	0							
8:15	0	0	0	0	0	0	0	0	0	0							
8:30										0							
8:45										0							
9:00										0							
9:15										0							
9:30										0							
9:45										0							
10:00										0							
10:15										0							
10:30										0							
10:45										0							
11:00	0	0	0	0	0	0	0	0	0	0							
11:15	0	0	1	0	1	0	0	0	0	2							
11:30	0	0	0	0	0	0	0	0	0	0							
11:45	0	0	2	1	2	0	1	0	0	1							
12:00	0	0	0	0	0	0	0	0	0	0							
12:15	0	0	0	0	0	0	0	0	0	0							
12:30	0	0	0	0	0	0	0	0	0	0							
12:45	0	0	1	0	0	0	1	0	0	2							
13:00										0							
13:15										0							
13:30										0							
13:45										0							
14:00										0							
14:15										0							
14:30										0							
14:45										0							
15:00										0							
15:15										0							
15:30										0							
15:45										0							
16:00	0	0	1	0	0	0	0	0	1	0							
16:15	0	0	0	0	0	0	1	0	0	1							
16:30	0	0	1	1	0	0	0	1	1	0							
16:45	0	0	0	0	0	0	1	0	0	1							
17:00	0	0	2	0	0	0	0	0	0	0							
17:15	0	0	1	0	0	1	1	0	0	0							
17:30	0	0	0	0	3	0	0	0	0	0							
17:45	0	0	0	0	0	1	0	0	1	0							
18:00										0							
18:15										0							
18:30										0							
18:45										0							
19:00										0							
19:15										0							
19:30										0							
19:45										0							
20:00										0							
20:15										0							
20:30										0							
20:45										0							
21:00										0							
21:15										0							
21:30										0							
21:45										0							
22:00										0							
22:15										0							
22:30										0							
22:45										0							
23:00										0							
23:15										0							
23:30										0							
23:45										0							
Total	0	1	9	2	6	1	5	1	7	0	4	1	7	2	4	2	52
AM Peak Hr:																	7:15
PK Vol	0	1	0	0	0	1	1	0	0	0	0	0	4	0	2	1	10
MID Peak Hr:																	12:00
PK Vol	0	0	1	0	0	0	0	0	1	0	0	0	1	0	0	0	3
PM Peak Hr:																	16:45
PK Vol	0	0	3	0	3	0	1	1	4	0	2	0	1	1	0	0	16

Intersection ID: 1805115
Count Date: 11/27/2018

N 7TH AVE & W BETHANY HOME RD

From North (SB) From East (WB) From South (NB) From West (EB)
N 7TH AVE W BETHANY HOME RD N 7TH AVE W BETHANY HOME RD INTSEC

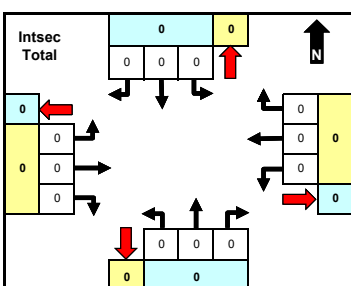
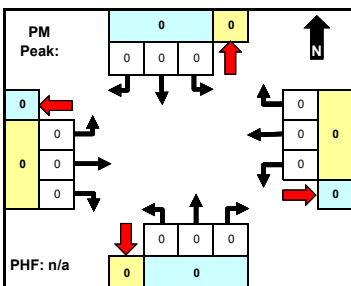
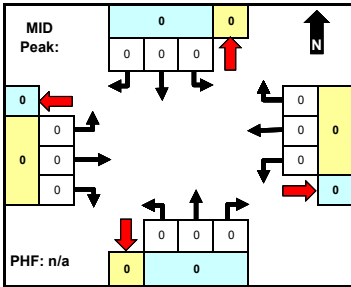
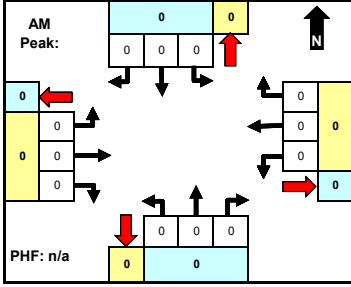

	North		East		South		West		Total
	App	Dep	App	Dep	App	Dep	App	Dep	
AM	0	0	0	0	0	0	0	0	0
MID	0	0	0	0	0	0	0	0	0
PM	0	0	0	0	0	0	0	0	0
Total	0	0	0	0	0	0	0	0	0

Comments
Unless shown otherwise, MID period defined as 10:00 AM - 2:00 PM. Peaks defined based on total intersection volume for all vehicle types.

Time	From North (SB)				From East (WB)				From South (NB)				From West (EB)				INTSEC	TOTAL
	LT	Thru	RT	U	LT	Thru	RT	U	LT	Thru	RT	U	LT	Thru	RT	U		
0:00																	0	
0:15																	0	
0:30																	0	
0:45																	0	
1:00																	0	
1:15																	0	
1:30																	0	
1:45																	0	
2:00																	0	
2:15																	0	
2:30																	0	
2:45																	0	
3:00																	0	
3:15																	0	
3:30																	0	
3:45																	0	
4:00																	0	
4:15																	0	
4:30																	0	
4:45																	0	
5:00																	0	
5:15																	0	
5:30																	0	
5:45																	0	
6:00																	0	
6:15																	0	
6:30	0	0	0	0	0	0	0	0	0	0	0	0	0	0	0	0	0	
6:45	0	0	0	0	0	0	0	0	0	0	0	0	0	0	0	0	0	
7:00	0	0	0	0	0	0	0	0	0	0	0	0	0	0	0	0	0	
7:15	0	0	0	0	0	0	0	0	0	0	0	0	0	0	0	0	0	
7:30	0	0	0	0	0	0	0	0	0	0	0	0	0	0	0	0	0	
7:45	0	0	0	0	0	0	0	0	0	0	0	0	0	0	0	0	0	
8:00	0	0	0	0	0	0	0	0	0	0	0	0	0	0	0	0	0	
8:15	0	0	0	0	0	0	0	0	0	0	0	0	0	0	0	0	0	
8:30																	0	
8:45																	0	
9:00																	0	
9:15																	0	
9:30																	0	
9:45																	0	
10:00																	0	
10:15																	0	
10:30																	0	
10:45																	0	
11:00	0	0	0	0	0	0	0	0	0	0	0	0	0	0	0	0	0	
11:15	0	0	0	0	0	0	0	0	0	0	0	0	0	0	0	0	0	
11:30	0	0	0	0	0	0	0	0	0	0	0	0	0	0	0	0	0	
11:45	0	0	0	0	0	0	0	0	0	0	0	0	0	0	0	0	0	
12:00	0	0	0	0	0	0	0	0	0	0	0	0	0	0	0	0	0	
12:15	0	0	0	0	0	0	0	0	0	0	0	0	0	0	0	0	0	
12:30	0	0	0	0	0	0	0	0	0	0	0	0	0	0	0	0	0	
12:45	0	0	0	0	0	0	0	0	0	0	0	0	0	0	0	0	0	
13:00																	0	
13:15																	0	
13:30																	0	
13:45																	0	
14:00																	0	
14:15																	0	
14:30																	0	
14:45																	0	
15:00																	0	
15:15																	0	
15:30																	0	
15:45																	0	
16:00	0	0	0	0	0	0	0	0	0	0	0	0	0	0	0	0	0	
16:15	0	0	0	0	0	0	0	0	0	0	0	0	0	0	0	0	0	
16:30	0	0	0	0	0	0	0	0	0	0	0	0	0	0	0	0	0	
16:45	0	0	0	0	0	0	0	0	0	0	0	0	0	0	0	0	0	
17:00	0	0	0	0	0	0	0	0	0	0	0	0	0	0	0	0	0	
17:15	0	0	0	0	0	0	0	0	0	0	0	0	0	0	0	0	0	
17:30	0	0	0	0	0	0	0	0	0	0	0	0	0	0	0	0	0	
17:45	0	0	0	0	0	0	0	0	0	0	0	0	0	0	0	0	0	
18:00																	0	
18:15																	0	
18:30																	0	
18:45																	0	
19:00																	0	
19:15																	0	
19:30																	0	
19:45																	0	
20:00																	0	
20:15																	0	
20:30																	0	
20:45																	0	
21:00																	0	
21:15																	0	
21:30																	0	
21:45																	0	
22:00																	0	
22:15																	0	
22:30																	0	
22:45																	0	
23:00																	0	
23:15																	0	
23:30																	0	
23:45																	0	
Total	0	0	0	0	0	0	0	0	0	0	0	0	0	0	0	0	0	
AM Peak Hr:																	7:15	
Pk Vol	0	0	0	0	0	0	0	0	0	0	0	0	0	0	0	0	0	
PHF	n/a	n/a	n/a	n/a	n/a	n/a	n/a	n/a	n/a	n/a	n/a	n/a	n/a	n/a	n/a	n/a	n/a	
MID Peak Hr:																	12:00	
Pk Vol	0	0	0	0	0	0	0	0	0	0	0	0	0	0	0	0	0	
PHF	n/a	n/a	n/a	n/a	n/a	n/a	n/a	n/a	n/a	n/a	n/a	n/a	n/a	n/a	n/a	n/a	n/a	
PM Peak Hr:																	16:45	
Pk Vol	0	0	0	0	0	0	0	0	0	0	0	0	0	0	0	0	0	
PHF	n/a	n/a	n/a	n/a	n/a	n/a	n/a	n/a	n/a	n/a	n/a	n/a	n/a	n/a	n/a	n/a	n/a	

Intersection ID: 1805114
Count Date: 11/27/2018

N 7TH AVE & W MARYLAND AVE

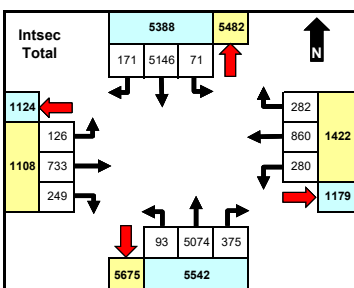
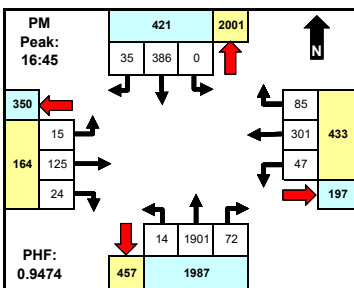
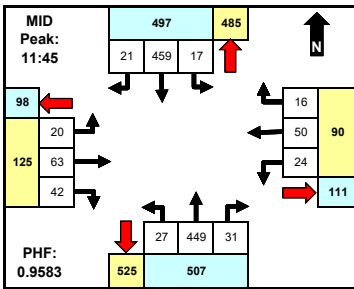
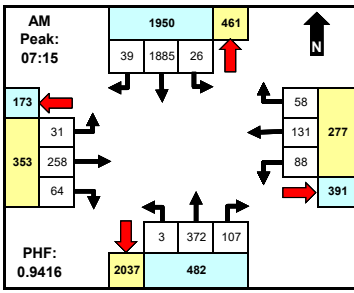

	North		East		South		West		Total
	App	Dep	App	Dep	App	Dep	App	Dep	
AM	1950	461	277	391	482	2037	353	173	3062
MID	497	485	90	111	507	525	125	98	1219
PM	421	2001	433	197	1987	457	164	350	3005
Total	5388	5482	1422	1179	5542	5675	1108	1124	13460

Comments

Unless shown otherwise, MID period defined as 10:00 AM - 2:00 PM. Peaks defined based on total intersection volume for all vehicle types.

Time	From North (SB)				From East (WB)				From South (NB)				From West (EB)				INTSEC	TOTAL
	N 7TH AVE		W MARYLAND AVE		N 7TH AVE		W MARYLAND AVE		N 7TH AVE		W MARYLAND AVE		N 7TH AVE		W MARYLAND AVE			
	LT	Thru	RT	U	LT	Thru	RT	U	LT	Thru	RT	U	LT	Thru	RT	U		
0:00																	0	
0:15																	0	
0:30																	0	
0:45																	0	
1:00																	0	
1:15																	0	
1:30																	0	
1:45																	0	
2:00																	0	
2:15																	0	
2:30																	0	
2:45																	0	
3:00																	0	
3:15																	0	
3:30																	0	
3:45																	0	
4:00																	0	
4:15																	0	
4:30																	0	
4:45																	0	
5:00																	0	
5:15																	0	
5:30																	0	
5:45																	0	
6:00																	0	
6:15																	0	
6:30	0	346	3	0	6	7	1	0	0	43	6	0	3	17	8	0	440	
6:45	2	420	12	0	8	11	3	0	1	68	11	0	6	29	20	0	591	
7:00	2	451	4	0	9	13	3	0	0	78	17	0	6	48	17	0	648	
7:15	3	538	8	0	8	16	3	0	0	66	16	0	11	69	24	0	762	
7:30	7	510	15	0	17	27	14	0	0	97	25	0	7	79	15	0	813	
7:45	9	452	6	0	28	40	15	0	2	103	30	0	5	61	10	0	761	
8:00	7	385	10	0	35	48	26	0	1	106	36	0	8	49	15	0	726	
8:15	6	412	7	0	30	36	39	0	1	91	24	0	6	46	11	0	709	
8:30																	0	
8:45																	0	
9:00																	0	
9:15																	0	
9:30																	0	
9:45																	0	
10:00																	0	
10:15																	0	
10:30																	0	
10:45																	0	
11:00	3	102	5	0	6	12	6	0	2	98	13	0	1	13	12	0	273	
11:15	2	93	4	0	13	11	6	0	12	96	9	0	7	14	8	0	275	
11:30	3	101	6	0	3	13	5	0	3	108	4	0	4	9	10	0	269	
11:45	5	115	7	0	8	12	3	0	10	103	7	0	4	18	13	0	305	
12:00	1	127	2	0	5	11	2	0	7	123	8	0	3	17	12	0	318	
12:15	6	121	7	0	7	11	7	0	5	111	9	0	3	17	6	0	310	
12:30	5	96	5	0	4	16	4	0	5	112	7	0	10	11	11	0	286	
12:45	1	103	6	0	8	7	4	0	9	128	5	0	2	14	10	0	297	
13:00																	0	
13:15																	0	
13:30																	0	
13:45																	0	
14:00																	0	
14:15																	0	
14:30																	0	
14:45																	0	
15:00																	0	
15:15																	0	
15:30																	0	
15:45																	0	
16:00	3	104	6	0	15	74	4	0	4	346	15	0	8	21	9	0	609	
16:15	2	68	9	0	9	66	16	0	7	443	19	0	7	27	3	0	676	
16:30	1	111	9	0	8	66	19	0	3	442	19	0	4	23	5	0	710	
16:45	0	90	8	0	9	81	16	0	3	500	16	0	1	45	5	0	774	
17:00	0	95	5	0	14	69	18	0	0	435	18	0	4	27	3	0	688	
17:15	0	92	8	0	11	75	21	0	6	511	24	0	6	32	7	0	793	
17:30	0	109	14	0	13	76	30	0	5	455	14	0	4	21	9	0	750	
17:45	3	105	5	0	6	62	17	0	7	411	23	0	6	26	6	0	677	
18:00																	0	
18:15																	0	
18:30																	0	
18:45																	0	
19:00																	0	
19:15																	0	
19:30																	0	
19:45																	0	
20:00																	0	
20:15																	0	
20:30																	0	
20:45																	0	
21:00																	0	
21:15																	0	
21:30																	0	
21:45																	0	
22:00																	0	
22:15																	0	
22:30																	0	
22:45																	0	
23:00																	0	
23:15																	0	
23:30																	0	
23:45																	0	
Total	71	5146	171	0	280	860	282	0	93	5074	375	0	126	733	249	0	13460	
AM Peak Hr:																	7:15	
PK Vol	26	1885	39	0	88	131	58	0	3	372	107	0	31	258	64	0	3062	
PHF	0.722	0.876	0.650	n/a	0.629	0.682	0.558	n/a	0.375	0.877	0.743	n/a	0.705	0.816	0.667	n/a	0.942	
MID Peak Hr:																	11:45	
PK Vol	17	459	21	0	24	50	16	0	27	449	31	0	20	63	42	0	1219	
PHF	0.708	0.904	0.750	n/a	0.750	0.781	0.571	n/a	0.675	0.913	0.861	n/a	0.500	0.875	0.808	n/a	0.958	
PM Peak Hr:																	16:45	
PK Vol	0	386	35	0	47	304	85	0	14	1901	72	0	15	125	24	0	3005	
PHF	n/a	0.885	0.625	n/a	0.839													

Intersection ID: 1805114
Count Date: 11/27/2018

N 7TH AVE & W MARYLAND AVE

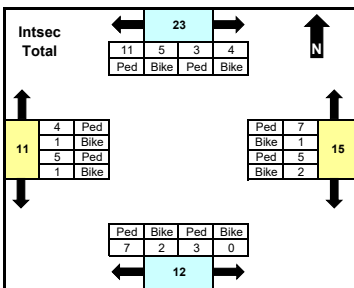
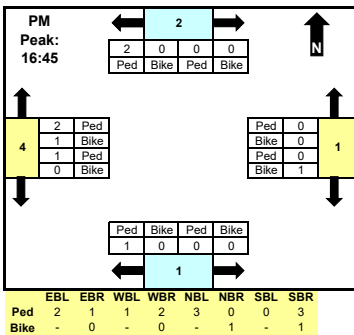
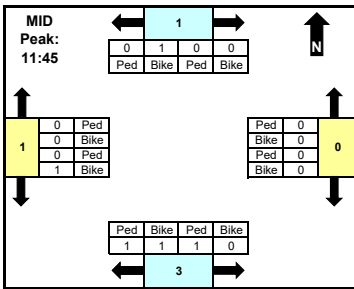
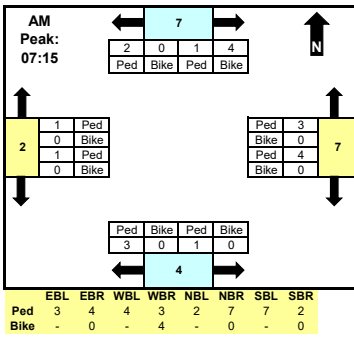

	North		East		South		West		Total
	CW	CCW	CW	CCW	CW	CCW	CW	CCW	
AM	5	2	4	3	3	1	1	1	20
MID	0	1	0	0	2	1	0	1	5
PM	0	2	1	0	1	0	3	1	8
Total	7	16	7	8	9	3	5	6	61

CW = Clockwise
CCW = Counter-clockwise

Comments

Unless shown otherwise, MID period defined as 10:00 AM - 2:00 PM. Crosswalk peaks defined based on total intersection volume for all vehicle types.

Time	North Leg		East Leg		South Leg		West Leg		INTSEC	TOTAL							
	CW	CCW	CW	CCW	CW	CCW	CW	CCW									
0:00										0							
0:15										0							
0:30										0							
0:45										0							
1:00										0							
1:15										0							
1:30										0							
1:45										0							
2:00										0							
2:15										0							
2:30										0							
2:45										0							
3:00										0							
3:15										0							
3:30										0							
3:45										0							
4:00										0							
4:15										0							
4:30										0							
4:45										0							
5:00										0							
5:15										0							
5:30										0							
5:45										0							
6:00										0							
6:15										0							
6:30	0	0	2	0	0	0	2	0	0	0	4						
6:45	1	0	0	1	0	0	0	1	0	0	3						
7:00	0	0	0	0	0	0	0	0	0	0	0						
7:15	0	0	1	0	1	0	0	1	0	0	3						
7:30	0	1	0	0	1	0	1	0	0	0	4						
7:45	1	0	0	1	0	2	0	1	0	0	5						
8:00	0	3	1	0	1	0	0	1	0	1	8						
8:15	1	0	0	0	1	0	0	0	0	0	3						
8:30											0						
8:45											0						
9:00											0						
9:15											0						
9:30											0						
9:45											0						
10:00											0						
10:15											0						
10:30											0						
10:45											0						
11:00	0	0	0	0	0	0	0	0	0	1	1						
11:15	0	0	0	0	0	0	0	0	0	0	0						
11:30	0	0	0	0	0	0	0	0	0	0	0						
11:45	0	0	0	0	0	0	0	0	0	0	0						
12:00	0	0	0	0	0	0	0	0	0	0	0						
12:15	0	0	0	0	0	0	0	1	0	0	1						
12:30	0	0	0	1	0	0	0	1	0	0	2						
12:45	0	0	0	0	0	0	0	1	0	0	1						
13:00											0						
13:15											0						
13:30											0						
13:45											0						
14:00											0						
14:15											0						
14:30											0						
14:45											0						
15:00											0						
15:15											0						
15:30											0						
15:45											0						
16:00	0	0	3	1	0	0	0	0	1	0	6						
16:15	0	0	1	0	0	1	1	0	0	0	4						
16:30	0	0	1	0	0	0	0	0	0	0	1						
16:45	0	0	0	0	0	1	0	0	0	0	1						
17:00	0	0	1	0	0	0	0	0	0	2	4						
17:15	0	0	1	0	0	0	0	1	0	0	2						
17:30	0	0	0	0	0	0	0	0	0	1	1						
17:45	0	0	0	2	0	0	2	0	0	0	4						
18:00											0						
18:15											0						
18:30											0						
18:45											0						
19:00											0						
19:15											0						
19:30											0						
19:45											0						
20:00											0						
20:15											0						
20:30											0						
20:45											0						
21:00											0						
21:15											0						
21:30											0						
21:45											0						
22:00											0						
22:15											0						
22:30											0						
22:45											0						
23:00											0						
23:15											0						
23:30											0						
23:45											0						
Total	3	4	11	5	5	2	7	1	7	2	3	0	4	1	5	1	61
AM Peak Hr:																	7:15
PK Vol	1	4	2	0	4	0	3	0	3	0	1	0	1	0	1	0	20
MID Peak Hr:																	11:45
PK Vol	0	0	0	1	0	0	0	0	1	1	1	0	0	0	0	1	5
PM Peak Hr:																	16:45
PK Vol	0	0	2	0	0	1	0	0	1	0	0	0	2	1	1	0	8

Intersection ID: 1805114
Count Date: 11/27/2018

N 7TH AVE & W MARYLAND AVE

From North (SB) From East (WB) From South (NB) From West (EB)
N 7TH AVE W MARYLAND AVE N 7TH AVE W MARYLAND AVE INTSEC

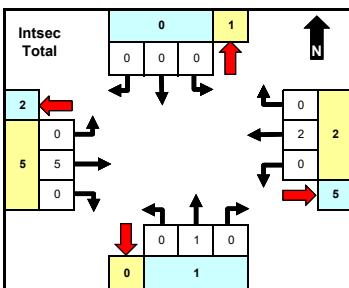
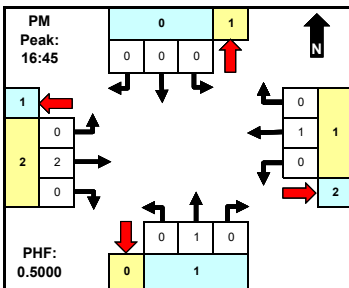
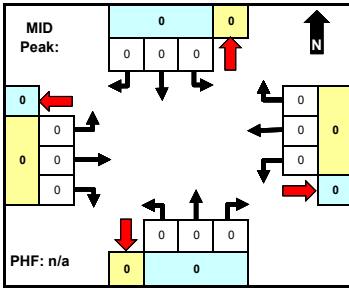
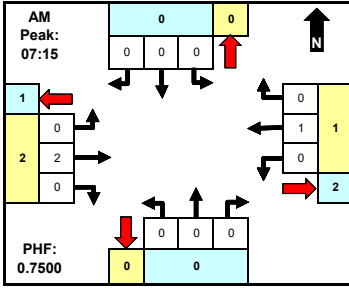

	North		East		South		West		Total
	App	Dep	App	Dep	App	Dep	App	Dep	
AM	0	0	1	2	0	0	2	1	3
MID	0	0	0	0	0	0	0	0	0
PM	0	1	1	2	1	0	2	1	4
Total	0	1	2	5	1	0	5	2	8

Comments

Unless shown otherwise, MID period defined as 10:00 AM - 2:00 PM. Peaks defined based on total intersection volume for all vehicle types.

Time	From North (SB)				From East (WB)				From South (NB)				From West (EB)				TOTAL
	LT	Thru	RT	U	LT	Thru	RT	U	LT	Thru	RT	U	LT	Thru	RT	U	
0:00																	0
0:15																	0
0:30																	0
0:45																	0
1:00																	0
1:15																	0
1:30																	0
1:45																	0
2:00																	0
2:15																	0
2:30																	0
2:45																	0
3:00																	0
3:15																	0
3:30																	0
3:45																	0
4:00																	0
4:15																	0
4:30																	0
4:45																	0
5:00																	0
5:15																	0
5:30																	0
5:45																	0
6:00																	0
6:15																	0
6:30	0	0	0	0	0	0	0	0	0	0	0	0	0	0	0	0	0
6:45	0	0	0	0	0	0	0	0	0	0	0	0	0	0	0	0	0
7:00	0	0	0	0	0	0	0	0	0	0	0	0	0	0	0	0	0
7:15	0	0	0	0	0	0	0	0	0	0	0	0	0	1	0	0	1
7:30	0	0	0	0	0	0	0	0	0	0	0	0	0	0	0	0	0
7:45	0	0	0	0	0	0	0	0	1	0	0	0	0	0	0	0	1
8:00	0	0	0	0	0	0	0	0	0	0	0	0	0	0	1	0	1
8:15	0	0	0	0	0	0	0	0	0	0	0	0	0	0	0	0	0
8:30																	0
8:45																	0
9:00																	0
9:15																	0
9:30																	0
9:45																	0
10:00																	0
10:15																	0
10:30																	0
10:45																	0
11:00	0	0	0	0	0	0	0	0	0	0	0	0	0	0	0	0	0
11:15	0	0	0	0	0	0	0	0	0	0	0	0	0	0	0	0	0
11:30	0	0	0	0	0	0	0	0	0	0	0	0	0	0	0	0	0
11:45	0	0	0	0	0	0	0	0	0	0	0	0	0	0	0	0	0
12:00	0	0	0	0	0	0	0	0	0	0	0	0	0	0	0	0	0
12:15	0	0	0	0	0	0	0	0	0	0	0	0	0	0	0	0	0
12:30	0	0	0	0	0	0	0	0	0	0	0	0	0	0	0	0	0
12:45	0	0	0	0	0	0	0	0	0	0	0	0	0	0	0	0	0
13:00																	0
13:15																	0
13:30																	0
13:45																	0
14:00																	0
14:15																	0
14:30																	0
14:45																	0
15:00																	0
15:15																	0
15:30																	0
15:45																	0
16:00	0	0	0	0	0	0	0	0	0	0	0	0	0	1	0	0	1
16:15	0	0	0	0	0	0	0	0	0	0	0	0	0	0	0	0	0
16:30	0	0	0	0	0	0	0	0	0	0	0	0	0	0	0	0	0
16:45	0	0	0	0	0	0	0	0	0	0	0	0	0	1	0	0	1
17:00	0	0	0	0	0	0	0	0	0	0	0	0	0	0	0	0	0
17:15	0	0	0	0	0	0	0	0	0	0	0	0	0	1	0	0	1
17:30	0	0	0	0	0	0	0	0	0	0	0	0	0	0	0	0	0
17:45	0	0	0	0	0	0	0	0	0	0	0	0	0	0	0	0	0
18:00																	0
18:15																	0
18:30																	0
18:45																	0
19:00																	0
19:15																	0
19:30																	0
19:45																	0
20:00																	0
20:15																	0
20:30																	0
20:45																	0
21:00																	0
21:15																	0
21:30																	0
21:45																	0
22:00																	0
22:15																	0
22:30																	0
22:45																	0
23:00																	0
23:15																	0
23:30																	0
23:45																	0
Total	0	0	0	0	0	0	2	0	0	0	1	0	0	0	5	0	8
AM Peak Hr:																	7:15
Pk Vol	0	0	0	0	0	1	0	0	0	0	0	0	0	2	0	0	3
PHF	n/a	n/a	n/a	n/a	n/a	0.250	n/a	n/a	n/a	n/a	n/a	n/a	n/a	0.500	n/a	n/a	0.750
MID Peak Hr:																	11:45
Pk Vol	0	0	0	0	0	0	0	0	0	0	0	0	0	0	0	0	0
PHF	n/a	n/a	n/a	n/a	n/a	n/a	n/a	n/a	n/a	n/a	n/a	n/a	n/a	n/a	n/a	n/a	n/a
PM Peak Hr:																	16:45
Pk Vol	0	0	0	0	0	1	0	0	0	1	0	0	0	2	0	0	4
PHF	n/a	n/a	n/a	n/a	n/a	0.250	n/a	n/a	n/a	0.250	n/a	n/a	n/a	0.500	n/a	n/a	0.500

Intersection ID: 1805113
Count Date: 11/27/2018

N 7TH AVE & W GLENDALE AVE

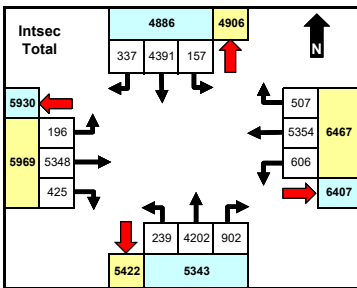
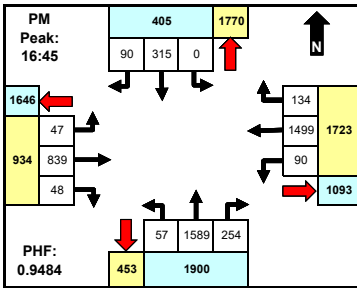
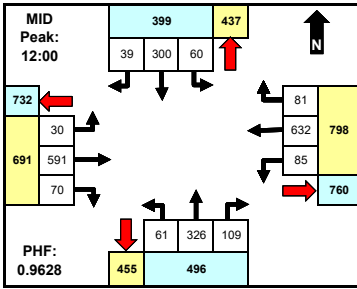
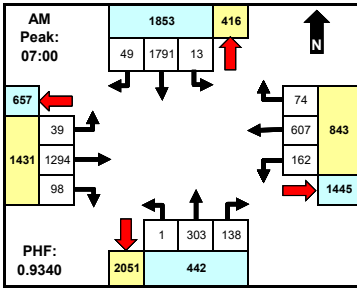

	North		East		South		West		Total
	App	Dep	App	Dep	App	Dep	App	Dep	
AM	1853	416	843	1445	442	2051	1431	657	4569
MID	399	437	798	760	496	455	691	732	2384
PM	405	1770	1723	1093	1900	453	934	1646	4962
Total	4886	4906	6467	6407	5343	5422	5969	5930	22665

Comments

Unless shown otherwise, MID period defined as 10:00 AM - 2:00 PM. Peaks defined based on total intersection volume for all vehicle types.

Time	From North (SB)				From East (WB)				From South (NB)				From West (EB)				INTSEC	TOTAL
	N 7TH AVE				W GLENDALE AVE				N 7TH AVE				W GLENDALE AVE					
	LT	Thru	RT	U	LT	Thru	RT	U	LT	Thru	RT	U	LT	Thru	RT	U		
0:00																	0	
0:15																	0	
0:30																	0	
0:45																	0	
1:00																	0	
1:15																	0	
1:30																	0	
1:45																	0	
2:00																	0	
2:15																	0	
2:30																	0	
2:45																	0	
3:00																	0	
3:15																	0	
3:30																	0	
3:45																	0	
4:00																	0	
4:15																	0	
4:30																	0	
4:45																	0	
5:00																	0	
5:15																	0	
5:30																	0	
5:45																	0	
6:00																	0	
6:15																	0	
6:30	3	286	4	0	33	107	7	0	0	23	20	0	4	349	19	0	855	
6:45	4	393	11	0	21	111	7	0	0	51	31	0	3	310	23	0	965	
7:00	4	394	10	0	27	123	10	0	0	49	32	0	6	378	28	0	1061	
7:15	3	522	13	0	40	134	18	0	1	65	46	0	9	335	18	0	1204	
7:30	5	472	12	0	49	162	28	0	0	82	32	0	16	322	23	0	1223	
7:45	1	403	14	0	46	168	18	0	0	107	28	0	8	259	29	0	1091	
8:00	2	320	12	0	28	163	18	0	0	90	37	0	6	293	38	0	997	
8:15	1	377	17	0	33	151	13	0	0	111	43	0	3	294	31	0	1074	
8:30																	0	
8:45																	0	
9:00																	0	
9:15																	0	
9:30																	0	
9:45																	0	
10:00																	0	
10:15																	0	
10:30																	0	
10:45																	0	
11:00	11	71	6	0	22	144	20	0	15	82	22	0	6	149	16	0	564	
11:15	22	65	9	0	19	154	13	0	10	64	23	0	4	145	16	0	544	
11:30	16	71	9	0	22	158	18	0	17	75	21	0	9	155	10	0	581	
11:45	21	81	8	0	22	161	14	0	15	70	24	0	5	143	11	0	575	
12:00	11	76	14	0	19	162	28	0	11	78	28	0	6	139	27	0	599	
12:15	12	82	8	0	21	168	20	0	18	87	24	0	9	153	17	0	619	
12:30	20	75	8	0	18	150	20	0	15	68	32	0	9	145	14	0	574	
12:45	17	67	9	0	27	152	13	0	17	93	25	0	6	154	12	0	592	
13:00																	0	
13:15																	0	
13:30																	0	
13:45																	0	
14:00																	0	
14:15																	0	
14:30																	0	
14:45																	0	
15:00																	0	
15:15																	0	
15:30																	0	
15:45																	0	
16:00	0	83	25	0	16	382	24	0	5	343	30	0	12	198	8	0	1126	
16:15	1	63	17	1	7	383	30	0	8	354	49	0	11	217	14	0	1155	
16:30	1	90	15	0	16	348	25	0	20	396	53	0	11	180	9	0	1164	
16:45	0	73	15	0	26	378	30	0	9	390	58	0	12	212	14	0	1217	
17:00	0	68	18	0	23	343	35	0	12	395	63	0	12	193	5	0	1167	
17:15	0	77	30	0	19	393	41	0	11	392	59	0	11	224	13	0	1270	
17:30	0	97	27	0	22	385	28	0	25	412	74	0	12	210	16	0	1308	
17:45	2	85	26	0	30	354	29	0	30	335	48	0	6	191	14	0	1150	
18:00																	0	
18:15																	0	
18:30																	0	
18:45																	0	
19:00																	0	
19:15																	0	
19:30																	0	
19:45																	0	
20:00																	0	
20:15																	0	
20:30																	0	
20:45																	0	
21:00																	0	
21:15																	0	
21:30																	0	
21:45																	0	
22:00																	0	
22:15																	0	
22:30																	0	
22:45																	0	
23:00																	0	
23:15																	0	
23:30																	0	
23:45																	0	
Total	157	4391	337	1	606	5354	507	0	239	4202	902	0	196	5348	425	0	22665	
AM Peak Hr:	7:00																	
Pk Vol	13	1791	49	0	162	607	74	0	1	303	138	0	39	1294	98	0	4569	
PHF	0.650	0.858	0.875	n/a	0.827	0.834	0.661	n/a	0.250	0.708	0.750	n/a	0.609	0.856	0.845	n/a	0.934	
MID Peak Hr:	12:00																	
Pk Vol	60	300	39	0	85	632	81	0	61	326	109	0	30	591	70	0	2384	
PHF	0.750	0.915	0.696	n/a	0.787	0.940	0.723	n/a	0.847	0.876	0.852	n/a	0.833	0.959	0.648	n/a	0.963	
PM Peak Hr:	16:45																	
Pk Vol	0	315	90	0	90	1499	134	0	57	1589 </								



Intersection ID: 1805113
Count Date: 11/27/2018

N 7TH AVE & W GLENDALE AVE

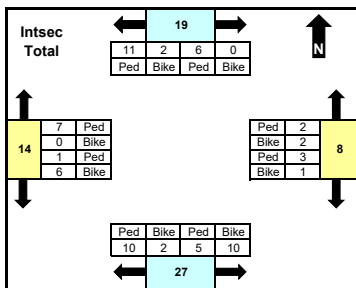
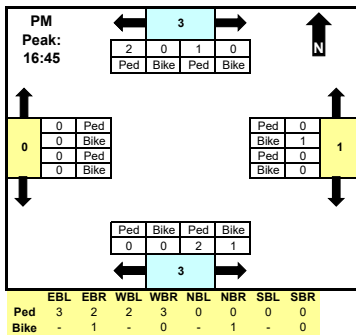
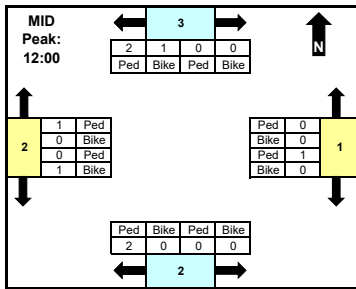
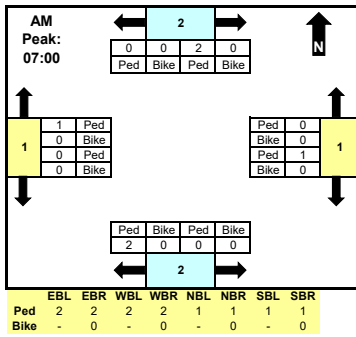

	North		East		South		West		Total
	CW	CCW	CW	CCW	CW	CCW	CW	CCW	
AM	2	0	1	0	2	0	1	0	6
MID	0	3	1	0	2	0	1	1	8
PM	1	2	0	1	0	3	0	0	7
Total	6	13	4	4	12	15	7	7	68

CW = Clockwise
CCW = Counter-clockwise

Comments

Unless shown otherwise, MID period defined as 10:00 AM - 2:00 PM. Crosswalk peaks defined based on total intersection volume for all vehicle types.

Time	North Leg		East Leg		South Leg		West Leg		INTSEC	TOTAL							
	CW	CCW	CW	CCW	CW	CCW	CW	CCW									
0:00										0							
0:15										0							
0:30										0							
0:45										0							
1:00										0							
1:15										0							
1:30										0							
1:45										0							
2:00										0							
2:15										0							
2:30										0							
2:45										0							
3:00										0							
3:15										0							
3:30										0							
3:45										0							
4:00										0							
4:15										0							
4:30										0							
4:45										0							
5:00										0							
5:15										0							
5:30										0							
5:45										0							
6:00										0							
6:15										0							
6:30	0	0	0	0	0	0	1	0	0	1							
6:45	0	0	0	0	0	0	0	0	0	0							
7:00	0	0	0	0	0	0	0	0	0	0							
7:15	0	0	0	0	0	0	0	0	0	0							
7:30	1	0	0	0	0	0	0	0	1	0							
7:45	1	0	0	0	1	0	0	0	0	0							
8:00	0	0	0	0	0	0	1	0	0	0							
8:15	0	0	1	0	0	0	0	0	0	0							
8:30										0							
8:45										0							
9:00										0							
9:15										0							
9:30										0							
9:45										0							
10:00										0							
10:15										0							
10:30										0							
10:45										0							
11:00	0	0	1	0	0	0	0	1	0	0							
11:15	1	0	2	0	0	0	0	2	1	0							
11:30	0	0	0	0	0	0	0	1	1	0							
11:45	0	0	0	0	0	0	1	0	0	0							
12:00	0	0	0	0	0	0	0	0	0	0							
12:15	0	0	0	1	0	0	0	0	0	1							
12:30	0	0	0	0	0	0	1	0	0	0							
12:45	0	0	2	0	1	0	0	0	0	0							
13:00										0							
13:15										0							
13:30										0							
13:45										0							
14:00										0							
14:15										0							
14:30										0							
14:45										0							
15:00										0							
15:15										0							
15:30										0							
15:45										0							
16:00	2	0	2	0	0	0	0	0	0	0							
16:15	0	0	0	0	1	0	0	0	0	0							
16:30	0	0	1	1	1	0	0	1	1	0							
16:45	0	0	0	0	0	0	0	0	0	0							
17:00	1	0	0	0	0	0	1	0	0	0							
17:15	0	0	1	0	0	0	0	0	0	0							
17:30	0	0	1	0	0	0	0	1	0	0							
17:45	0	0	0	0	0	0	0	0	0	0							
18:00										0							
18:15										0							
18:30										0							
18:45										0							
19:00										0							
19:15										0							
19:30										0							
19:45										0							
20:00										0							
20:15										0							
20:30										0							
20:45										0							
21:00										0							
21:15										0							
21:30										0							
21:45										0							
22:00										0							
22:15										0							
22:30										0							
22:45										0							
23:00										0							
23:15										0							
23:30										0							
23:45										0							
Total	6	0	11	2	3	1	2	2	10	2	5	10	7	0	1	6	68
AM Peak Hr:																	7:00
PK Vol	2	0	0	0	1	0	0	0	2	0	0	0	1	0	0	0	6
MID Peak Hr:																	12:00
PK Vol	0	0	2	1	1	0	0	0	2	0	0	0	1	0	0	1	8
PM Peak Hr:																	16:45
PK Vol	1	0	2	0	0	0	0	1	0	0	2	1	0	0	0	0	7

Intersection ID: 1805113
Count Date: 11/27/2018

N 7TH AVE & W GLENDALE AVE

From North (SB) From East (WB) From South (NB) From West (EB)
N 7TH AVE W GLENDALE AVE N 7TH AVE W GLENDALE AVE INTSEC

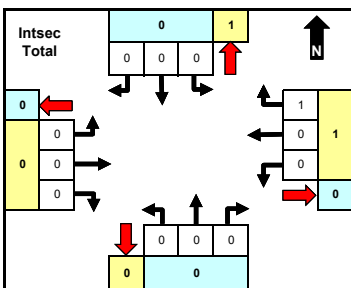
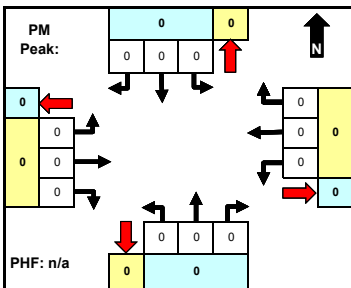
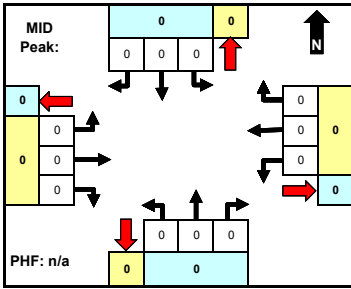
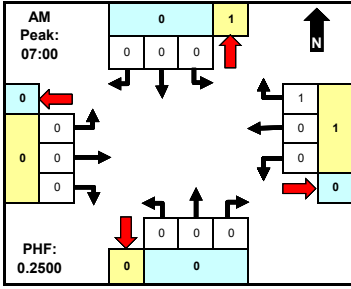

	North		East		South		West		Total
	App	Dep	App	Dep	App	Dep	App	Dep	
AM	0	1	1	0	0	0	0	0	1
MID	0	0	0	0	0	0	0	0	0
PM	0	0	0	0	0	0	0	0	0
Total	0	1	1	0	0	0	0	0	1

Comments

Unless shown otherwise, MID period defined as 10:00 AM - 2:00 PM. Peaks defined based on total intersection volume for all vehicle types.

Time	From North (SB)				From East (WB)				From South (NB)				From West (EB)				TOTAL
	LT	Thru	RT	U	LT	Thru	RT	U	LT	Thru	RT	U	LT	Thru	RT	U	
0:00																	0
0:15																	0
0:30																	0
0:45																	0
1:00																	0
1:15																	0
1:30																	0
1:45																	0
2:00																	0
2:15																	0
2:30																	0
2:45																	0
3:00																	0
3:15																	0
3:30																	0
3:45																	0
4:00																	0
4:15																	0
4:30																	0
4:45																	0
5:00																	0
5:15																	0
5:30																	0
5:45																	0
6:00																	0
6:15																	0
6:30	0	0	0	0	0	0	0	0	0	0	0	0	0	0	0	0	0
6:45	0	0	0	0	0	0	0	0	0	0	0	0	0	0	0	0	0
7:00	0	0	0	0	0	0	1	0	0	0	0	0	0	0	0	0	1
7:15	0	0	0	0	0	0	0	0	0	0	0	0	0	0	0	0	0
7:30	0	0	0	0	0	0	0	0	0	0	0	0	0	0	0	0	0
7:45	0	0	0	0	0	0	0	0	0	0	0	0	0	0	0	0	0
8:00	0	0	0	0	0	0	0	0	0	0	0	0	0	0	0	0	0
8:15	0	0	0	0	0	0	0	0	0	0	0	0	0	0	0	0	0
8:30																	0
8:45																	0
9:00																	0
9:15																	0
9:30																	0
9:45																	0
10:00																	0
10:15																	0
10:30																	0
10:45																	0
11:00	0	0	0	0	0	0	0	0	0	0	0	0	0	0	0	0	0
11:15	0	0	0	0	0	0	0	0	0	0	0	0	0	0	0	0	0
11:30	0	0	0	0	0	0	0	0	0	0	0	0	0	0	0	0	0
11:45	0	0	0	0	0	0	0	0	0	0	0	0	0	0	0	0	0
12:00	0	0	0	0	0	0	0	0	0	0	0	0	0	0	0	0	0
12:15	0	0	0	0	0	0	0	0	0	0	0	0	0	0	0	0	0
12:30	0	0	0	0	0	0	0	0	0	0	0	0	0	0	0	0	0
12:45	0	0	0	0	0	0	0	0	0	0	0	0	0	0	0	0	0
13:00																	0
13:15																	0
13:30																	0
13:45																	0
14:00																	0
14:15																	0
14:30																	0
14:45																	0
15:00																	0
15:15																	0
15:30																	0
15:45																	0
16:00	0	0	0	0	0	0	0	0	0	0	0	0	0	0	0	0	0
16:15	0	0	0	0	0	0	0	0	0	0	0	0	0	0	0	0	0
16:30	0	0	0	0	0	0	0	0	0	0	0	0	0	0	0	0	0
16:45	0	0	0	0	0	0	0	0	0	0	0	0	0	0	0	0	0
17:00	0	0	0	0	0	0	0	0	0	0	0	0	0	0	0	0	0
17:15	0	0	0	0	0	0	0	0	0	0	0	0	0	0	0	0	0
17:30	0	0	0	0	0	0	0	0	0	0	0	0	0	0	0	0	0
17:45	0	0	0	0	0	0	0	0	0	0	0	0	0	0	0	0	0
18:00	0	0	0	0	0	0	0	0	0	0	0	0	0	0	0	0	0
18:15																	0
18:30																	0
18:45																	0
19:00																	0
19:15																	0
19:30																	0
19:45																	0
20:00																	0
20:15																	0
20:30																	0
20:45																	0
21:00																	0
21:15																	0
21:30																	0
21:45																	0
22:00																	0
22:15																	0
22:30																	0
22:45																	0
23:00																	0
23:15																	0
23:30																	0
23:45																	0
Total	0	0	0	0	0	0	0	1	0	0	0	0	0	0	0	0	1
AM Peak Hr:																	7:00
Pk Vol	0	0	0	0	0	0	1	0	0	0	0	0	0	0	0	0	1
PHF	n/a	n/a	n/a	n/a	n/a	n/a	0.250	n/a	n/a	n/a	n/a	n/a	n/a	n/a	n/a	n/a	0.250
MID Peak Hr:																	12:00
Pk Vol	0	0	0	0	0	0	0	0	0	0	0	0	0	0	0	0	0
PHF	n/a	n/a	n/a	n/a	n/a	n/a	n/a	n/a	n/a	n/a	n/a	n/a	n/a	n/a	n/a	n/a	n/a
PM Peak Hr:																	16:45
Pk Vol	0	0	0	0	0	0	0	0	0	0	0	0	0	0	0	0	0
PHF	n/a	n/a	n/a	n/a	n/a	n/a	n/a	n/a	n/a	n/a	n/a	n/a	n/a	n/a	n/a	n/a	n/a



Intersection ID: 1805112
Count Date: 11/27/2018

N 7TH AVE & W NORTHERN AVE

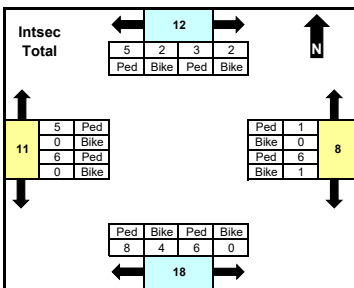
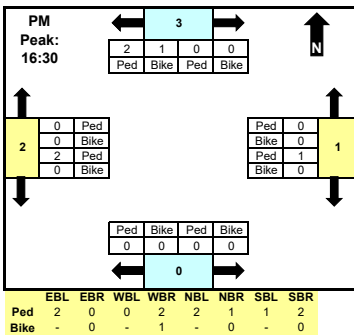
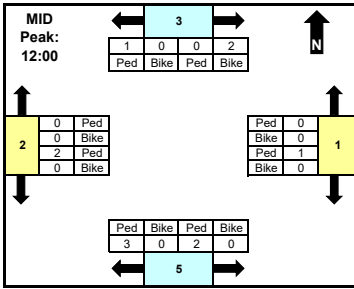
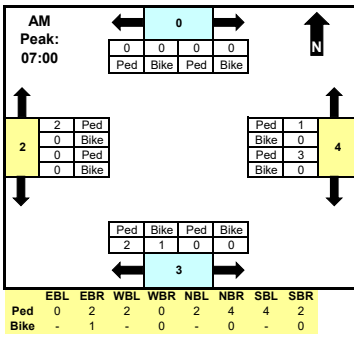

	North		East		South		West		Total
	CW	CCW	CW	CCW	CW	CCW	CW	CCW	
AM	0	0	3	1	3	0	2	0	9
MID	2	1	1	0	3	2	0	2	11
PM	0	3	1	0	0	0	0	2	6
Total	5	7	7	1	12	6	5	6	49

CW = Clockwise
CCW = Counter-clockwise

Comments

Unless shown otherwise, MID period defined as 10:00 AM - 2:00 PM. Crosswalk peaks defined based on total intersection volume for all vehicle types.

Time	North Leg		East Leg		South Leg		West Leg		INTSEC	TOTAL							
	CW	CCW	CW	CCW	CW	CCW	CW	CCW									
0:00										0							
0:15										0							
0:30										0							
0:45										0							
1:00										0							
1:15										0							
1:30										0							
1:45										0							
2:00										0							
2:15										0							
2:30										0							
2:45										0							
3:00										0							
3:15										0							
3:30										0							
3:45										0							
4:00										0							
4:15										0							
4:30										0							
4:45										0							
5:00										0							
5:15										0							
5:30										0							
5:45										0							
6:00										0							
6:15										0							
6:30	0	0	0	0	0	0	0	0	0	1							
6:45	0	0	0	0	0	0	0	0	0	1							
7:00	0	0	0	0	1	0	0	0	0	2							
7:15	0	0	0	0	0	0	1	1	0	3							
7:30	0	0	0	0	2	0	0	0	0	2							
7:45	0	0	0	0	0	0	1	0	0	2							
8:00	0	0	0	0	0	0	0	1	0	0							
8:15	0	0	0	0	0	0	0	0	1	2							
8:30										0							
8:45										0							
9:00										0							
9:15										0							
9:30										0							
9:45										0							
10:00										0							
10:15										0							
10:30										0							
10:45										0							
11:00	0	0	0	0	0	0	0	0	0	0							
11:15	0	0	0	0	0	0	0	0	0	1							
11:30	0	0	0	0	0	0	0	1	0	0							
11:45	0	0	1	0	0	0	0	0	0	1							
12:00	0	0	0	0	0	0	0	0	0	0							
12:15	0	0	0	0	0	0	2	0	1	3							
12:30	0	2	1	0	0	0	1	0	1	6							
12:45	0	0	0	1	0	0	0	0	1	2							
13:00										0							
13:15										0							
13:30										0							
13:45										0							
14:00										0							
14:15										0							
14:30										0							
14:45										0							
15:00										0							
15:15										0							
15:30										0							
15:45	0	0	0	0	0	0	2	0	0	4							
16:00	1	0	0	1	1	1	0	0	0	7							
16:15	0	0	1	1	1	0	0	0	0	5							
16:30	0	0	0	0	0	0	0	0	0	0							
16:45	0	0	0	0	0	0	0	0	0	0							
17:00	0	0	0	0	0	0	0	0	0	0							
17:15	0	0	1	0	0	0	0	0	0	1							
17:30	2	0	1	0	0	0	0	0	0	3							
17:45	0	0	0	0	0	0	0	0	0	0							
18:00										0							
18:15										0							
18:30										0							
18:45										0							
19:00										0							
19:15										0							
19:30										0							
19:45										0							
20:00										0							
20:15										0							
20:30										0							
20:45										0							
21:00										0							
21:15										0							
21:30										0							
21:45										0							
22:00										0							
22:15										0							
22:30										0							
22:45										0							
23:00										0							
23:15										0							
23:30										0							
23:45										0							
Total	3	2	5	2	6	1	1	0	8	4	6	0	5	0	6	0	49
AM Peak Hr:																	7:00
PK Vol	0	0	0	0	3	0	1	0	2	1	0	0	2	0	0	0	9
MID Peak Hr:																	12:00
PK Vol	0	2	1	0	1	0	0	0	3	0	2	0	0	0	2	0	11
PM Peak Hr:																	16:30
PK Vol	0	0	2	1	1	0	0	0	0	0	0	0	0	0	2	0	6

Intersection ID: 1805112
Count Date: 11/27/2018

N 7TH AVE & W NORTHERN AVE

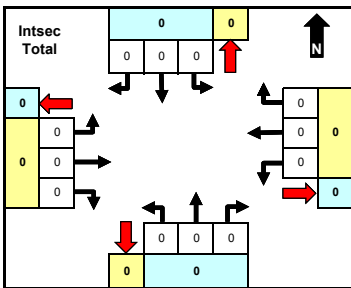
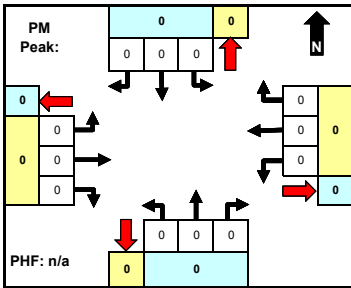
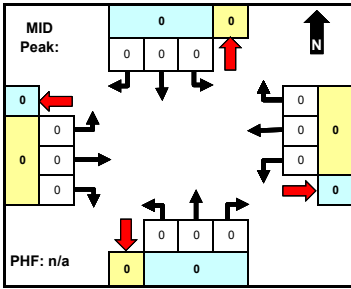
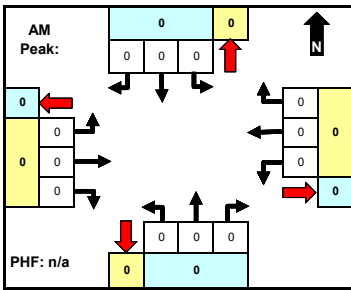

	North		East		South		West		Total
	App	Dep	App	Dep	App	Dep	App	Dep	
AM	0	0	0	0	0	0	0	0	0
MID	0	0	0	0	0	0	0	0	0
PM	0	0	0	0	0	0	0	0	0
Total	0	0	0	0	0	0	0	0	0

Comments

Unless shown otherwise, MID period defined as 10:00 AM - 2:00 PM. Peaks defined based on total intersection volume for all vehicle types.

Time	From North (SB)				From East (WB)				From South (NB)				From West (EB)				INTSEC	TOTAL
	N 7TH AVE				W NORTHERN AVE				N 7TH AVE				W NORTHERN AVE					
	LT	Thru	RT	U	LT	Thru	RT	U	LT	Thru	RT	U	LT	Thru	RT	U		
0:00																	0	
0:15																	0	
0:30																	0	
0:45																	0	
1:00																	0	
1:15																	0	
1:30																	0	
1:45																	0	
2:00																	0	
2:15																	0	
2:30																	0	
2:45																	0	
3:00																	0	
3:15																	0	
3:30																	0	
3:45																	0	
4:00																	0	
4:15																	0	
4:30																	0	
4:45																	0	
5:00																	0	
5:15																	0	
5:30																	0	
5:45																	0	
6:00																	0	
6:15																	0	
6:30	0	0	0	0	0	0	0	0	0	0	0	0	0	0	0	0	0	
6:45	0	0	0	0	0	0	0	0	0	0	0	0	0	0	0	0	0	
7:00	0	0	0	0	0	0	0	0	0	0	0	0	0	0	0	0	0	
7:15	0	0	0	0	0	0	0	0	0	0	0	0	0	0	0	0	0	
7:30	0	0	0	0	0	0	0	0	0	0	0	0	0	0	0	0	0	
7:45	0	0	0	0	0	0	0	0	0	0	0	0	0	0	0	0	0	
8:00	0	0	0	0	0	0	0	0	0	0	0	0	0	0	0	0	0	
8:15	0	0	0	0	0	0	0	0	0	0	0	0	0	0	0	0	0	
8:30																	0	
8:45																	0	
9:00																	0	
9:15																	0	
9:30																	0	
9:45																	0	
10:00																	0	
10:15																	0	
10:30																	0	
10:45																	0	
11:00	0	0	0	0	0	0	0	0	0	0	0	0	0	0	0	0	0	
11:15	0	0	0	0	0	0	0	0	0	0	0	0	0	0	0	0	0	
11:30	0	0	0	0	0	0	0	0	0	0	0	0	0	0	0	0	0	
11:45	0	0	0	0	0	0	0	0	0	0	0	0	0	0	0	0	0	
12:00	0	0	0	0	0	0	0	0	0	0	0	0	0	0	0	0	0	
12:15	0	0	0	0	0	0	0	0	0	0	0	0	0	0	0	0	0	
12:30	0	0	0	0	0	0	0	0	0	0	0	0	0	0	0	0	0	
12:45	0	0	0	0	0	0	0	0	0	0	0	0	0	0	0	0	0	
13:00																	0	
13:15																	0	
13:30																	0	
13:45																	0	
14:00																	0	
14:15																	0	
14:30																	0	
14:45																	0	
15:00																	0	
15:15																	0	
15:30																	0	
15:45																	0	
16:00	0	0	0	0	0	0	0	0	0	0	0	0	0	0	0	0	0	
16:15	0	0	0	0	0	0	0	0	0	0	0	0	0	0	0	0	0	
16:30	0	0	0	0	0	0	0	0	0	0	0	0	0	0	0	0	0	
16:45	0	0	0	0	0	0	0	0	0	0	0	0	0	0	0	0	0	
17:00	0	0	0	0	0	0	0	0	0	0	0	0	0	0	0	0	0	
17:15	0	0	0	0	0	0	0	0	0	0	0	0	0	0	0	0	0	
17:30	0	0	0	0	0	0	0	0	0	0	0	0	0	0	0	0	0	
17:45	0	0	0	0	0	0	0	0	0	0	0	0	0	0	0	0	0	
18:00																	0	
18:15																	0	
18:30																	0	
18:45																	0	
19:00																	0	
19:15																	0	
19:30																	0	
19:45																	0	
20:00																	0	
20:15																	0	
20:30																	0	
20:45																	0	
21:00																	0	
21:15																	0	
21:30																	0	
21:45																	0	
22:00																	0	
22:15																	0	
22:30																	0	
22:45																	0	
23:00																	0	
23:15																	0	
23:30																	0	
23:45																	0	
Total	0	0	0	0	0	0	0	0	0	0	0	0	0	0	0	0	0	
AM Peak Hr:																	7:00	
Pk Vol	0	0	0	0	0	0	0	0	0	0	0	0	0	0	0	0	0	
PHF	n/a	n/a	n/a	n/a	n/a	n/a	n/a	n/a	n/a	n/a	n/a	n/a	n/a	n/a	n/a	n/a	n/a	
MID Peak Hr:																	12:00	
Pk Vol	0	0	0	0	0	0	0	0	0	0	0	0	0	0	0	0	0	
PHF	n/a	n/a	n/a	n/a	n/a	n/a	n/a	n/a	n/a	n/a	n/a	n/a	n/a	n/a	n/a	n/a	n/a	
PM Peak Hr:																	16:30	
Pk Vol	0	0	0	0	0	0	0	0	0	0	0	0	0	0	0	0	0	
PHF	n/a	n/a	n/a	n/a	n/a	n/a	n/a	n/a	n/a	n/a	n/a	n/a	n/a	n/a	n/a	n/a	n/a	